



71.040.2PCF(3S)

TWO POST LIFT

INSTRUCTION & MAINTENANCE MANUAL



Jimy Industrial Pty Ltd
5 Cord St
Dudley Park, 5008
Ph: (08) 8269 9700
W: www.jimytools.com.au
E: sales@jimytools.com.au



Read this entire manual carefully and completely before installation or operation of the lift.

INDEX

1. Important safety instructions.....	3~4
1.1 Important notices	
1.2 Qualified personnel	
1.3 Danger notices	
1.4 Training	
1.5 Warning signs	
2. Overview of the lift.....	5
2.1 General descriptions	
2.2 Technical data	
2.3 Construction of the lift	
3. Installation instructions.....	6~11
3.1 Preparations before installation	
3.2 Precautions for installation	
3.3 Installation	
3.4 Items to be checked after installation	
4. Operation instructions.....	11~12
4.1 Precautions	
4.2 Flow chart for operation	
4.3 Operation instructions	
5. Trouble shooting.....	13
6. Maintenance.....	14
7. Annex.....	15~21
Annex1, Overall diagram	
Annex2, Hydraulic working system	
Annex 3, Assembly drawings	

IMPORTANT SAFETY INSTRUCTIONS

1.1 Important notices

we will offer one-year's quality warranty for the whole machine, during which any quality problem will be properly solved to the user's satisfaction. However, we will not take any responsibility for whatever bad consequence resulted from improper installation and operation, overload running or unqualified ground condition.

This 2-posts lift is specially designed for lifting motor vehicles that weighs within its outmost lifting capacity. Users are not allowed to use it for any other purposes. Otherwise, we, as well as our sales agency, will not bear any responsibility for accidents or damages of the lift. Make sure to pay careful attention to the label of the lifting capacity attached on the lift and never try to lift cars with its weight beyond.

Read this manual carefully before operating the machine so as to avoid economic loss or personnel casualty incurred by wrong operation. Without professional advice, users are not permitted to make any modification to the control unit or whatever mechanical unit.

1.2 Qualified personnel

1.2.1 Only these qualified staff, who have been properly trained, can operate the lift.

1.2.2 Electrical connection must be done by a competent electrician.

1.2.3 People who are not concerned are not allowed in the lifting area.

1.3 Danger notices

1.3.1 Do not install the lift on any asphalt surface.

1.3.2 Read and understand all safety warnings before operating the lift.

1.3.3 The lift, if is not specially designed upon customer's request, is not fit for outdoor use.

1.3.4 Keep hands and feet away from any moving parts. Keep feet clear of the lift when lowering.

1.3.5 Only these qualified people, who have been properly trained, can operate the lift.

1.3.6 Do not wear unfit clothes such as large clothes with flounces, tires, etc, which could be caught by moving parts of the lift.

1.3.7 To prevent evitable incidents, surrounding areas of the lift must be tidy and with nothing unconcerned.

1.3.8 The lift is simply designed to lift the entire body of vehicles, with its maximum weight within the lifting capacity.

1.3.9 Always insure the safety latches are engaged before any attempt to work near or under the vehicle.

1.3.10 Make sure to place the lifting pads to the positions as suggested by vehicle makers and when gradually lift the vehicle to the desired height, operators should be certain that the vehicle will not slant, roll-over or slide in lifting process.

1.3.11 Check at any time the parts the lift to ensure the agility of moving parts and the performance of synchronization. Ensure regular maintenance and if anything abnormal occurs, stop using the lift immediately and contact our dealers for help.

1.3.12 Lower the lift to its lowest position and do remember to cut off the power source when service finishes.

1.3.13 Do not modify any parts of the lift without manufacturer's advice.

1.3.14 If the lift is going to left used for a long time, users are required to:

- a. Disconnect the power source;
- b. Empty the oil tank;
- c. Lubricate the moving parts with hydraulic oil.













1.4 Training

Only these qualified people, who have been properly trained, can operate the lift. We are quite willing to provide professional training for the users when necessary.

Attention: For environment protection, please dispose the disused oil in a proper way.

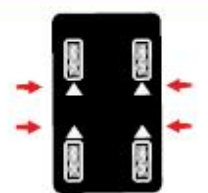
1.5 Warning signs

All safety warning signs attached on the machine are for the purpose of drawing the user's attention to safety operation. The labels must be kept clean and need to be replaced when they are worn-out or have dropped. Read the explanations of the labels carefully and try to memorize them.

 <p>ATTENTION</p> <p>The presence of persons (during lifting or lowering) underneath the lift is forbidden!</p>	 <p>ATTENTION</p> <p>Keep emergency exits clear!</p>	 <p>ATTENTION</p> <p>Repairs by qualified personnel only!</p>	 <p>ATTENTION</p> <p>Avoid strong shaking of the vehicle!</p>
 <p>ATTENTION</p> <p>Always use only one adapter per arm. Distribute the weight of the vehicle evenly on the four arms!</p>	 <p>ATTENTION</p> <p>Pay attention to your feet while lowering the lift!</p>	 <p>ATTENTION</p> <p>Usage of the lift by qualified personnel only!</p>	 <p>ATTENTION</p> <p>Only qualified personnel allowed within the lift area!</p>
 <p>ATTENTION</p> <p>Please pay attention to the manufacturers fixing points!</p>	 <p>ATTENTION</p> <p>Safety restraints are to be used during lifting of heavy loads!</p>		
 <p>ATTENTION</p> <p>Use adapter (one per sensor) to ensure a better grip. Check if the transporter adapter is positioned correctly!</p>	 <p>ATTENTION</p> <p>Do not overload the lift! The usage of other objects between the sensor and motor vehicle are prohibited!</p>		

OVERVIEW OF THE LIFT

2.1 General descriptions

This machine composed of posts, carriages, lifting arms, cylinders and motor unit, etc.

It is driven by an electro-hydraulic system. The gear pump delivers hydraulic oil to oil cylinders and pushes upwards its piston. The piston drives the chain to raise the carriage and the lifting arms. During lifting process, the safety latch will automatically and firmly bite with the safety teeth block in the posts. Therefore, no slipping will happen in case the hydraulic system beaks down.

Safety structure

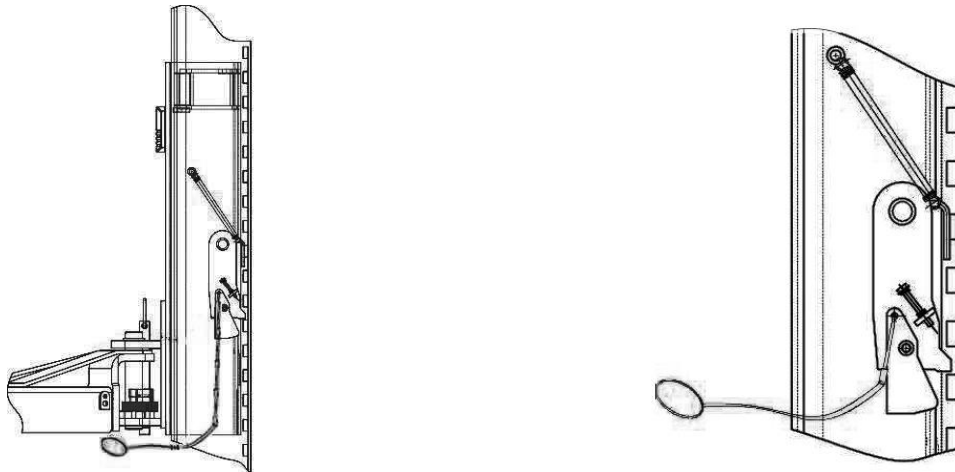

2.2 Technical data

Model	Lifting capacity	Full rise time	Full rise	Height	Width	Inside columns
	4000kg	45s	1930mm	3740mm	3365mm	2780mm

2.3 Construction of the lift

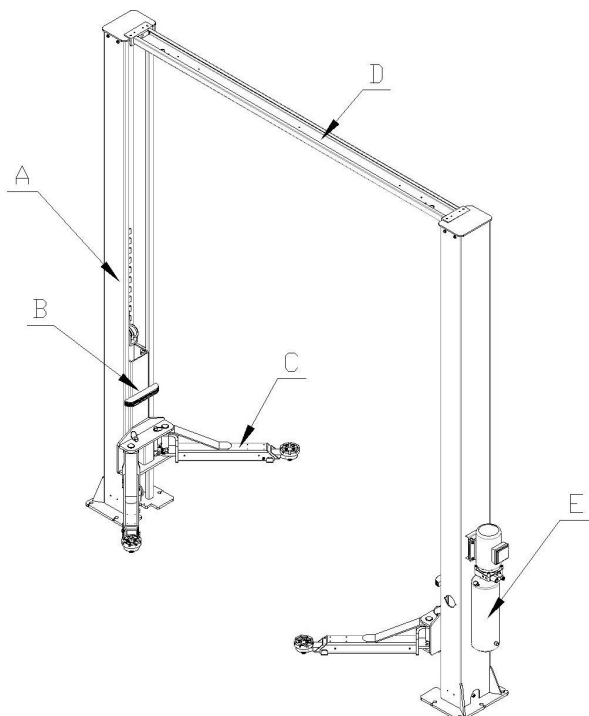

A	Column
B	Carriage
C	Lifting arm
D	Top beam
E	Power unit

INSTALLATION INSCRUCTIONS

3.1 Preparations before installation

3.1.1 Tools and equipments needed

- ✓ Appropriate lifting equipment
- ✓ Anti-abrasion hydraulic oil.
- ✓ Rotary Hammer Drill with 3/4" drill bit.
- ✓ Chalk and tape measure, magnetic plump, 8 metersΦ15 level pipe.
- ✓ Sockets and open wrenches, a set of inside hex wrenches, cross and straight screw drivers.
- ✓ Hammer, 4pounds, sharp nose pliers, Φ17,Φ19,Φ22 socket spanners.

3.1.2 List for parts checking ---Annex 1 (Packing list)

Unfold the package and check if any parts missed as per Annex 1. Do not hesitate to contact us in case any parts missed, but if you do not contact us and insist installing upon the lack of some parts, well as our dealers will not bear any responsibility for this and will charge for any parts subsequently demanded by the buyer.

3.1.3 Ground conditions

The lift should be fixed on a smooth and solid concrete ground with its strength more than 3000psi, tolerance of flatness less than 5mm and minimum thickness of 150mm. In addition, newly built concrete ground must undergo more than 28days' cure and reinforcement.

3.2 Precautions for installation

3.2.1 Make sure the two posts stand paralleled and are vertical to the ground. No slanting.

3.2.2 Joints of oil hose and steel cable must be firmly connected in order to avoid the looseness of steel cable and leakage of oil hose.

3.2.3 All bolts should be firmly screwed up.

3.2.4 Do not place any vehicle on the lift in the case of trial running.

3.3 Installation

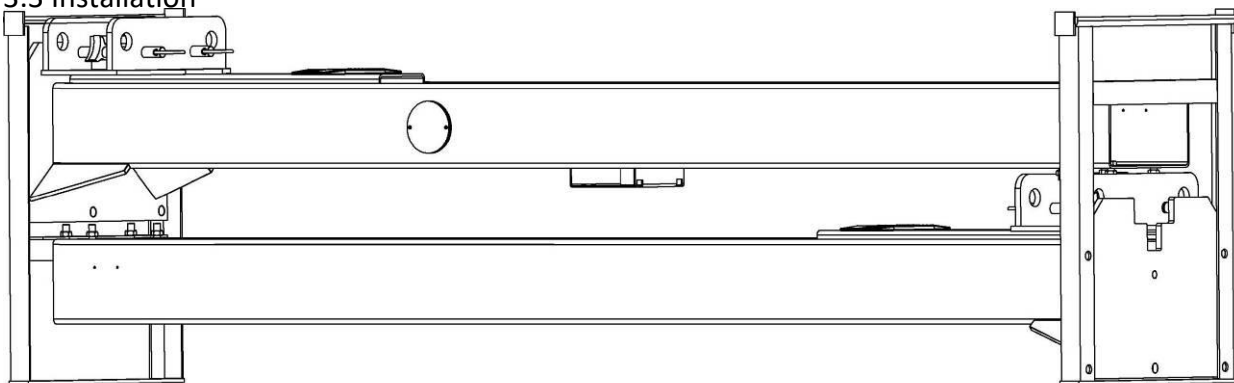

Step 1: Remove the packaging, take out the carton for accessories and cover plate.

Step 2: Firstly, put something supporting between the two posts or suspend one of the posts by a crane and then remove the bolts on the package.

Attention: Please pay special attention not to let the post fall down for it may cause casualty or bring damages to the accessories fixed in the post.

Step3: When the first post has been taken away, place something supporter under the second post and then remove the bolts on the package.

Step 4: Fix the standing position for the two posts. (See Annex 3, floor plan)

1. Unfold the package and decide on which post the power unit will be mounted.
2. Draw an outline of the base plate on the ground with chalk and ascertain the position for the post.

Step 5: Erect the posts, power side post first and then the other post.

1. Drill anchor holes for expansion bolts on the ground with an electrical drill. Make sure to drill vertically.
2. After holes have been drilled, remove thoroughly the debris and dust in them and ascertain that the posts stay upon the circle previously drawn by chalk.

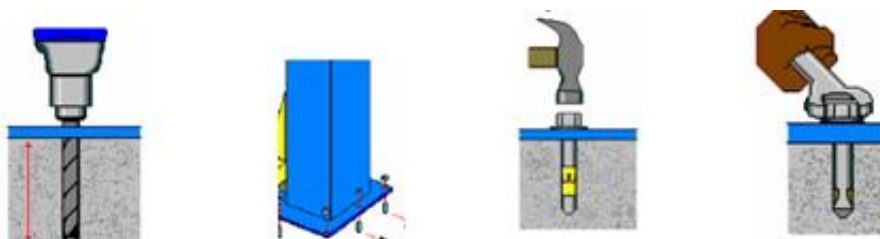

Step6: Connect steel cables.

1. Route and fix according to the following diagram of steel cable connection.
2. Raise carriages on both sides approximately 800mm above the ground. Carriages must be on the same height from the floor.
3. Make sure that the mechanical safety locks in each post are fully engaged before attempting to route cables.
4. After the cable being fixed, adjust and make the cable at both sides be with the same tightness which could be judged by the sound emitted during lifting process. Make judge and adjustment after trial running.
5. Grease after being fixed. (It is a must.)

A	Top beam pulley
B	Base plate pulley
C	Steel cable 1
D	Steel cable 2
E	Wire rope boom seat post
F	M16 nut

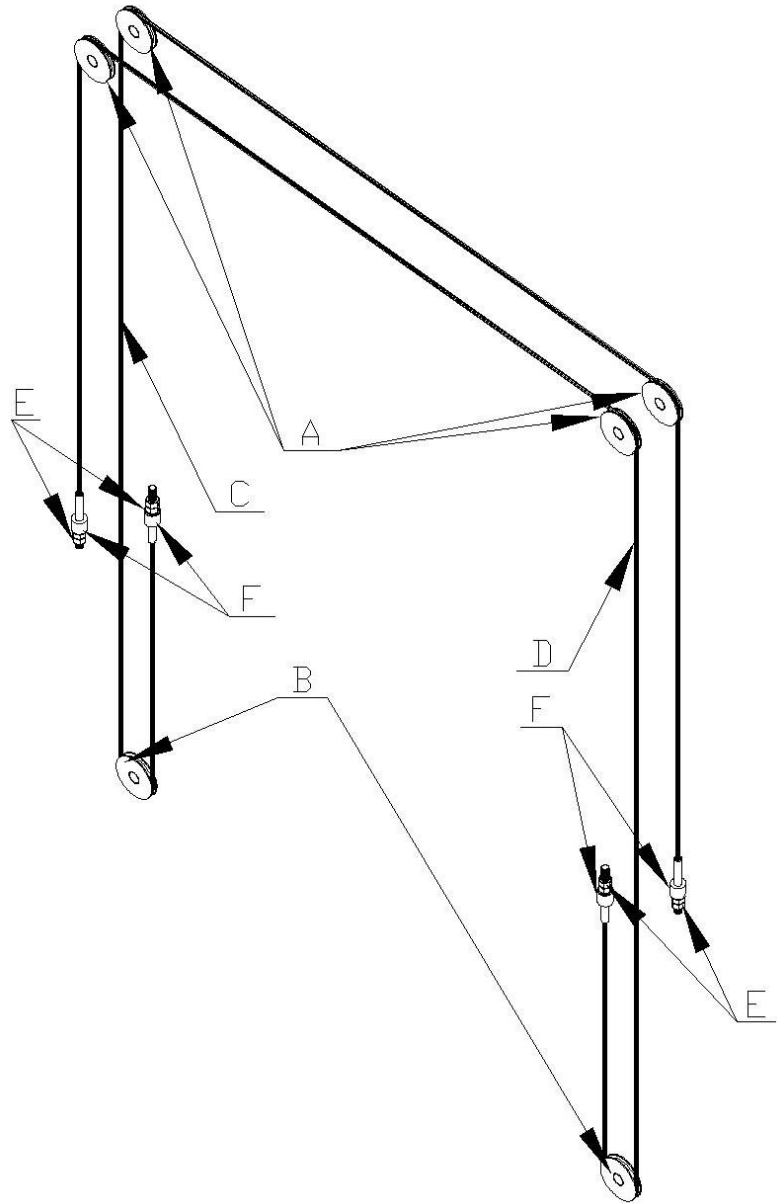

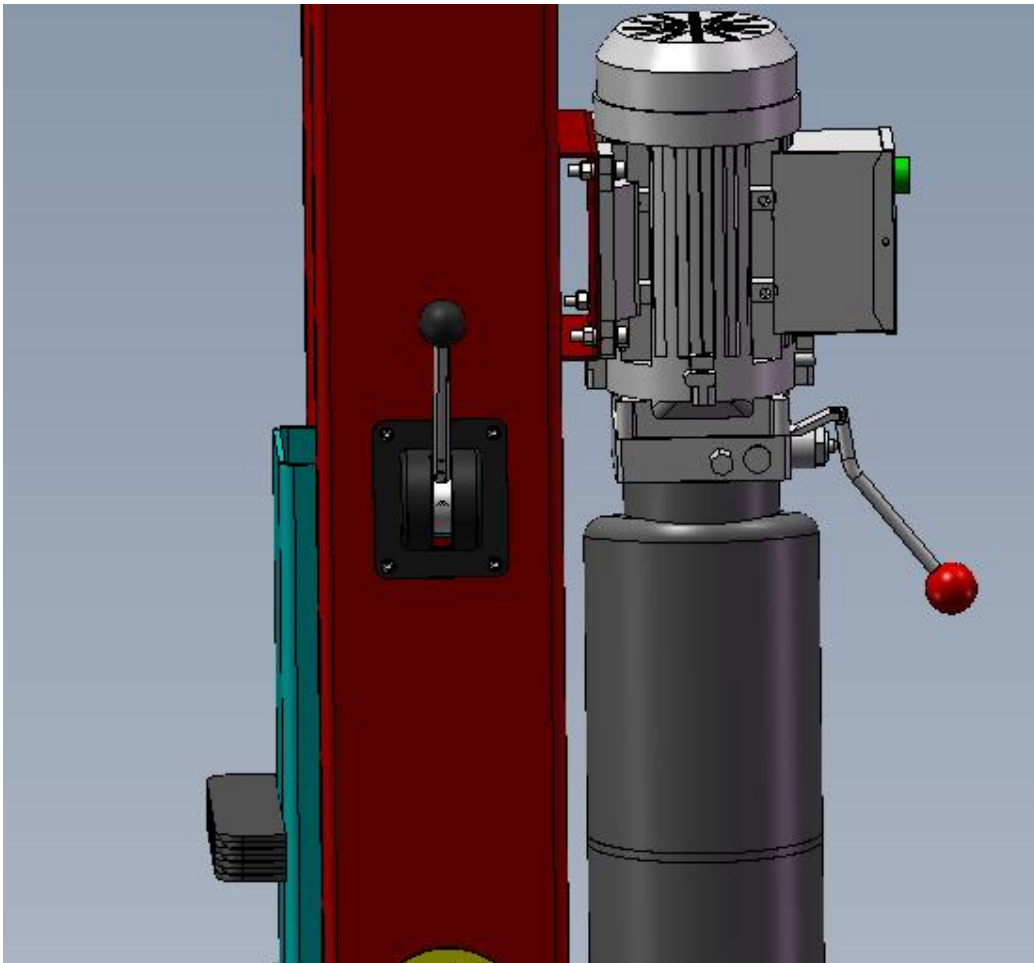

**Unilateral manually
unlocking**

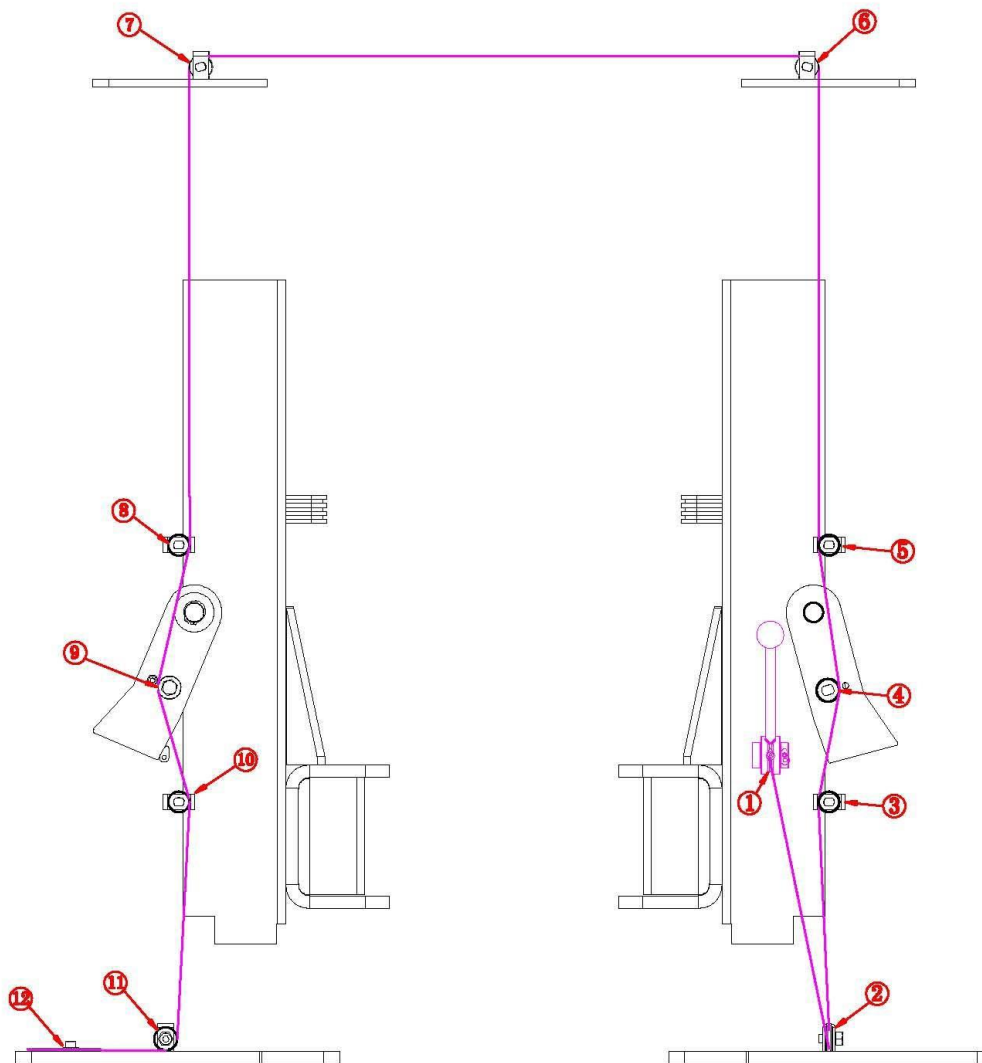

Safety mechanism

Step7: Mount the power unit onto the power side post.

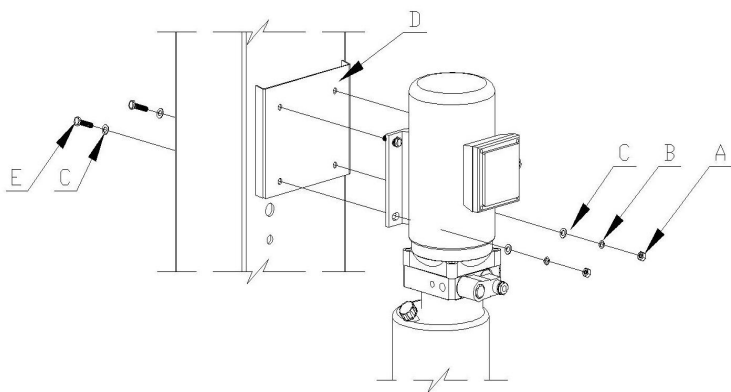

A	φ8 nuts
B	φ8 spring washer
C	φ8 flat washe
D	Motor hanging hole
E	M8×25 full thread hex flanges bolt

Step8: Connect oil hoses.

Connect the oil hose as per the following diagram.

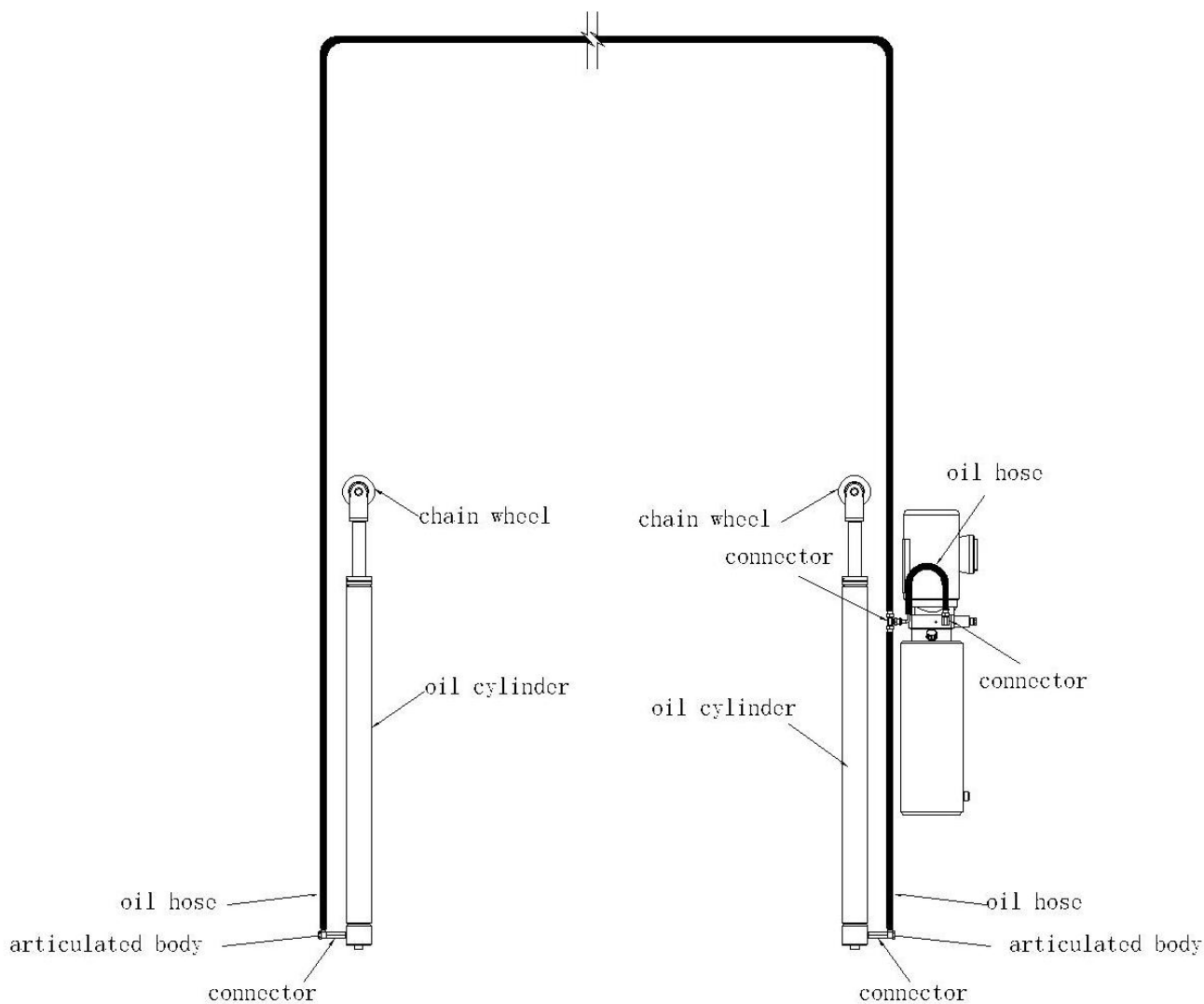

Step9: Install lifting arms.

Connect the lifting arm and the carriage by shafts.

Install the lifting arms onto the carriages and ensure the arm lock could work.

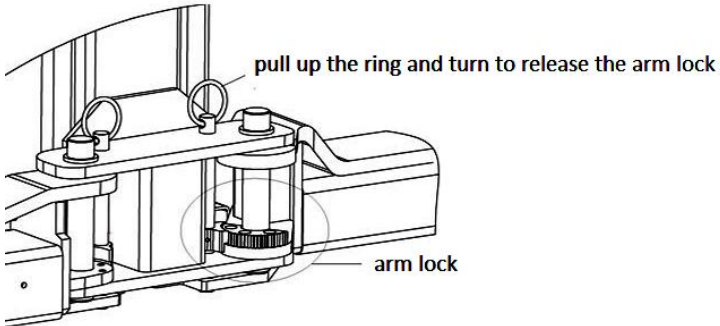

Step10: Fill with hydraulic oil.

The volume of oil tank is 10L.To insure the lift work normally, the amount of oil in it should at least reach 80% of the tank's total volume.

32#anti-abrasion hydraulic oil for winter, 46# for summer.

Step11: Trial running.

1. Do refer to the operation instructions in advance and keep in mind that no vehicle left on the lift in the process of trial running.
2. Check if mechanical locks can be well engaged or released in the running process. Adjust by screwing the hex head screw as showed in the following drawing in case the locks do not work well. (Screw clockwise in case the lock can not release and screw counterclockwise in case the lock can't be engaged.)

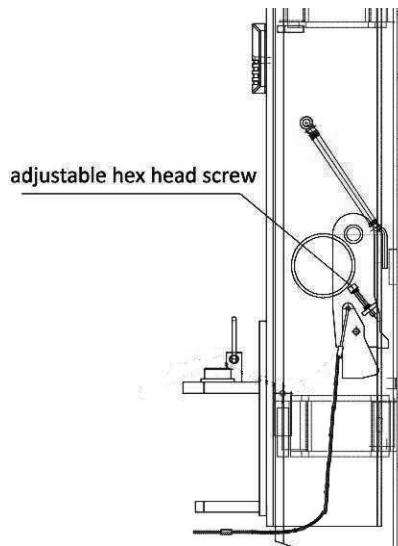

3. Check and ensure all the connections are in good condition.

4. No vehicle on the lift during trial running.

3.4 Items to be checked after installation.

S/N	Check items	YES	NO
1	Are the posts vertical to the floor?		
2	Are the two posts paralleled?		
3	Is the oil hose well connected?		
4	Is the steel cable well connected?		
5	Are all lifting arms well fixed?		
6	Are electrical connections right?		
7	Are the rest joints firmly screwed?		
8	Are all items need lubricating added with grease?		

OPERATION INSTRUCTIONS

4.1 Precautions

4.1.1 Check all the joints of oil hose. Only when there is no leakage, the lift can start work.

4.1.2 The lift, if its safety device malfunctions, shall not be used.

4.1.3 The machine shall not lift or lower an automobile if its center of gravity is not positioned midway of the swing arms. Otherwise, the we as well as our dealers will not bear any responsibility for any consequence resulted thereby.

4.1.4 Operators and other personnel concerned should stand in a safety area during lifting and lowering process.

4.1.5 When lifting arms rise to the desired height, switch off the power at once to prevent any mal-operation done by unconcerned people.

4.1.6. Make sure the safety lock of the lift is engaged before start working under the vehicle and no people under the vehicle during lifting and lowering process.

4.2 Flow chart for operation

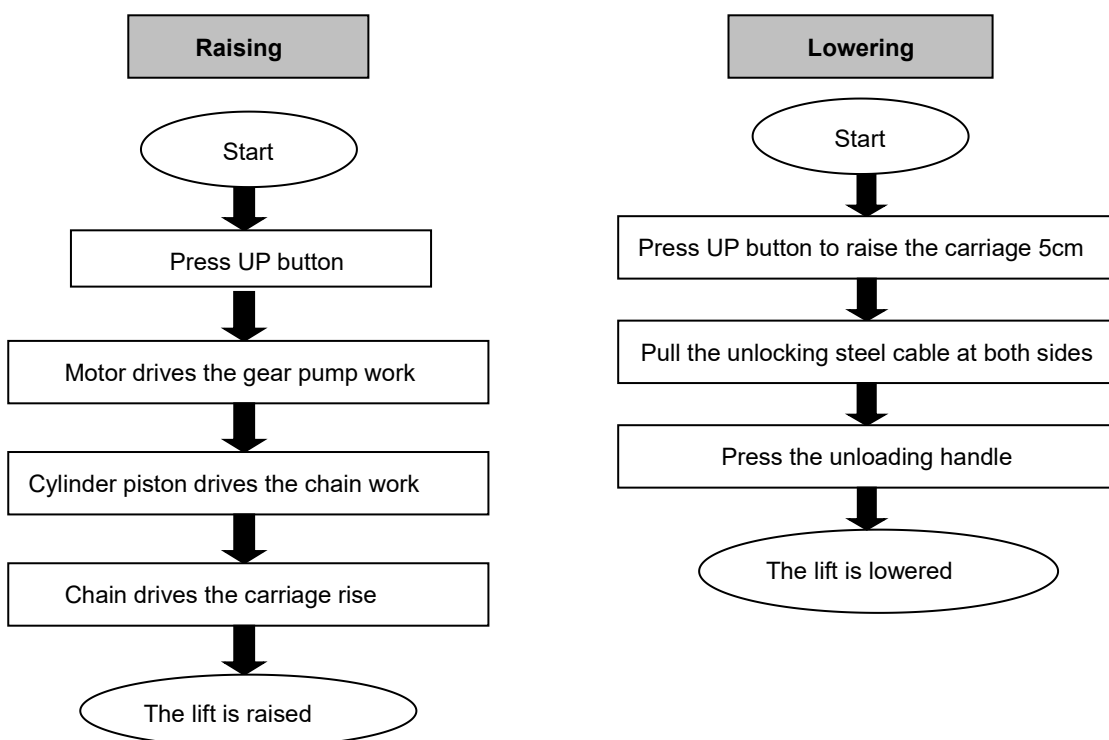

4.3 Operation instructions

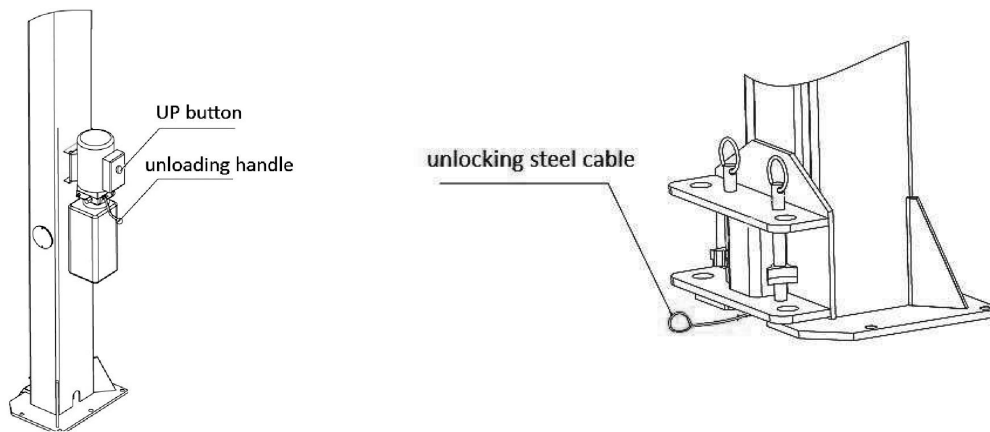

Raise the lift

1. Make sure that you have read and understood the operation manual before operation.
2. Park the vehicle between two posts.
3. Adjust the lifting arms until they reach the supporting positions of the vehicle and make sure the gravity of vehicle located in the center of four lifting arms.
4. Connect the power supply as per requirements on the nameplate attached, and switch on.
5. Press the "UP" button on the control box until pads of lifting arms touched the prop-position of vehicle.
6. Keep on raising the vehicle to let it have a bit clearance from the ground and check again its stability.
7. Raise the vehicle to the desired height, check it is safe or not, press the "unlocking handle" button to have the safety locks engaged, and then perform maintenance or repair work underneath.

Lower the lift

1. Press the "UP" button on the control box to raise the lifting arms about 5CM which loses the safety lock.
2. Pull the unlocking steel cable at both sides to release the safety locks.
3. Press the unloading handle to lower the arms.
4. After the lifting arms lower to the lowest position, pull them out from under the vehicle and clear up all the obstacles.
5. Drive the vehicle away.

TROUBLE SHOOTING

ATTENTION: If the trouble could not be fixed by yourself, please do not hesitate to contact us for help .We will offer our service at the earliest time we can. By the way, troubles could be judged and solved much faster if more details or pictures could be provided.

TROUBLES	CAUSE	SOLUTION
Abnormal noise	Abrasion exists on insider surface of the posts.	Grease the inside of the post.
	Trash in the post.	Clear the trash
Motor does not run and will not rise	The wire connection is loose.	Check and make a good connection.
	The motor is blown.	Replace it.
	The limit switch is damaged or the wire connection is loose.	Connect it or adjust or replace the limit switch.
Motor runs but will not raise	The motor run reversely.	Check the wire connection.
	Overflow valve is loose or jammed.	Clean or adjust it.
	The gear pump is damaged.	Replace it.
	Oil level is too low.	Add oil.
	The oil hose became loose or dropped off.	Tighten it.
	The cushion valve became loose or jammed.	Clean or adjusts it.
Carriages go down slowly after being raised	The oil hose leaks.	Check or replace it.
	The oil cylinder is not tightened.	Replace the seal.
	The single valve leaks.	Clean or replace it.
	Solenoid valve fails to work well.	Clean or replace it.
	Steel cable is loose or not with same tightness.	Check and adjust the tightness.
Raising too slow	The oil filter is jammed.	Clean or replace it.
	Oil level is too low.	Add oil.
	The overflow valve is not adjusted to the right position.	Adjust it.
	The hydraulic oil is too hot (above 45°) .	Change the oil.
	The seal of the cylinder is abraded.	Replace the seal.
	Inside surface of the posts is not well greased.	Add grease.
Lowering too slow	The throttle valve jammed.	Clean or replace.
	The hydraulic oil is dirty.	Change the oil.
	The anti-surge valve jammed.	Clean it.
	The oil hose jammed.	Replace it.
The steel cable is abraded	No grease when installation or out of lifetime.	Replace it.

MAINTENANCE

Easy and low cost routine maintenance can ensure the lift work normally and safely. Following are requirements for routine maintenance. Frequency of routine maintenance is determined by working condition and frequency.

THE FOLLOWING PARTS ARE NEEDED TO BE LUBRICATED

A	Column
B	Carriage
C	Lifting arm
D	Top beam
E	Power unit

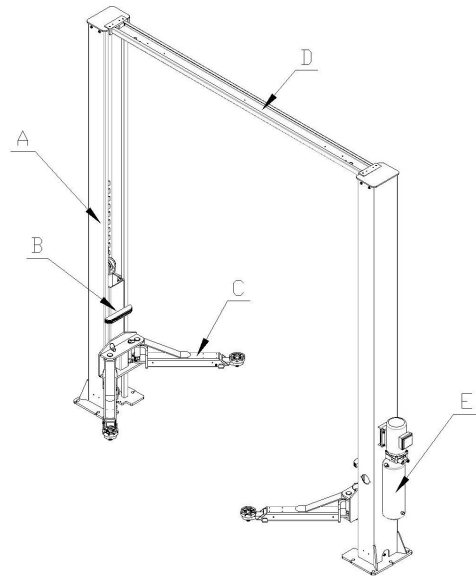

6.1 Daily checking items before operation

The user must perform daily check. Daily check of safety lock system is very important – the discovery of device failure before action could save time and prevent great loss, injury or casualty.

- Before operation, judge whether the safety locks are engaged by sound.
- Check whether oil hose well connected and whether it leaks or not.
- Check the connections of chain and steel cable and check the power unit.
- Check whether expansion bolts are firmly screwed.
- Check if arm lock works well or not.

6.2 Weekly checking items

- Check the flexibility of moving parts.
- Check the working conditions of safety parts.
- Check the amount of oil left in the oil tank. Oil is enough if the carriage can be raised to highest position. Otherwise, oil is insufficient.
- Check whether expansion bolts firmly screwed.

6.3 Monthly checking items

- Check whether expansion bolts are firmly screwed.
- Check the tightness of the hydraulic system and screw firm the joints if it leaks.
- Check the lubrication and abrasion circumstance of axial pins, carriages, lifting arms and other related parts and replace in time with new ones if they failed to work well.
- Check the lubrication and abrasion circumstance of steel cable.

6.4 Yearly checking items

- Empty the oil tank and check the quality of hydraulic oil.
- Wash and clean the oil filter.

If users strictly follow the above maintenance requirements, the lift will keep in a good working condition and meanwhile accidents could be avoided to a large extent.

ANNEX

Annex1, Overall diagram

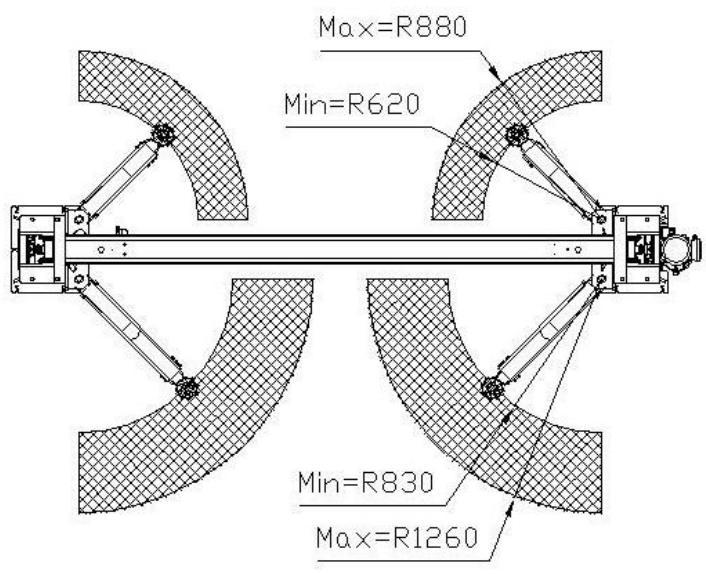
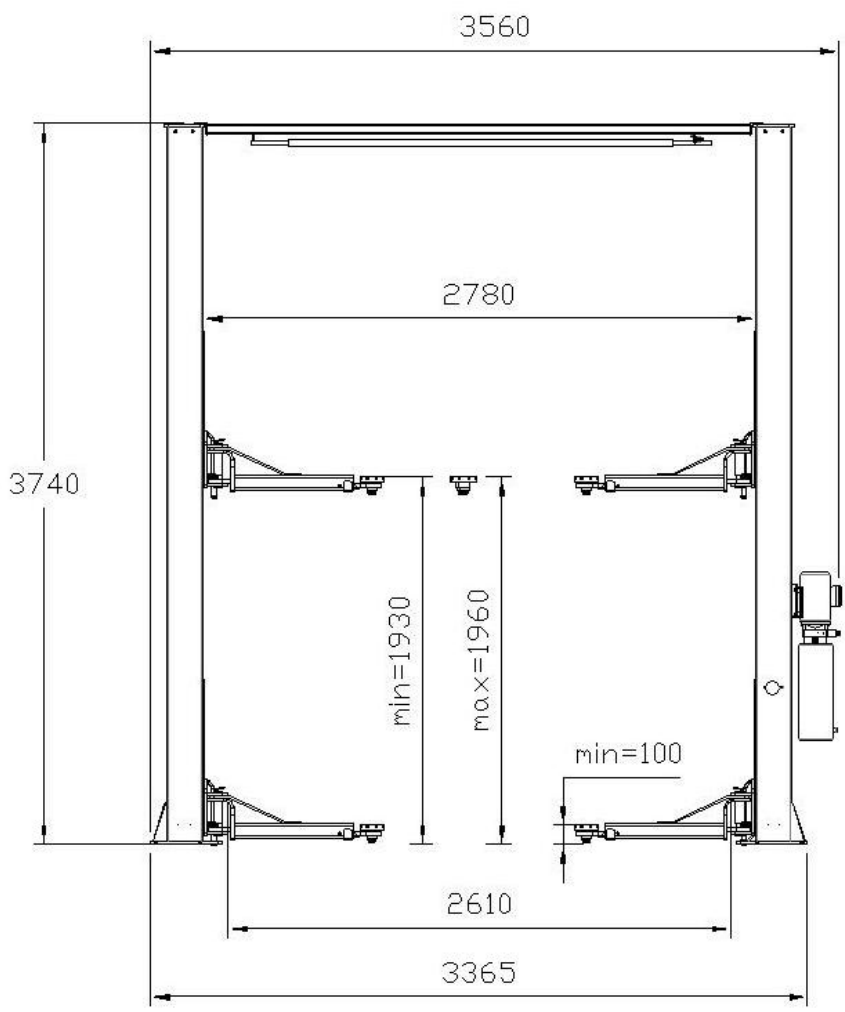

Annex 2, Hydraulic working system

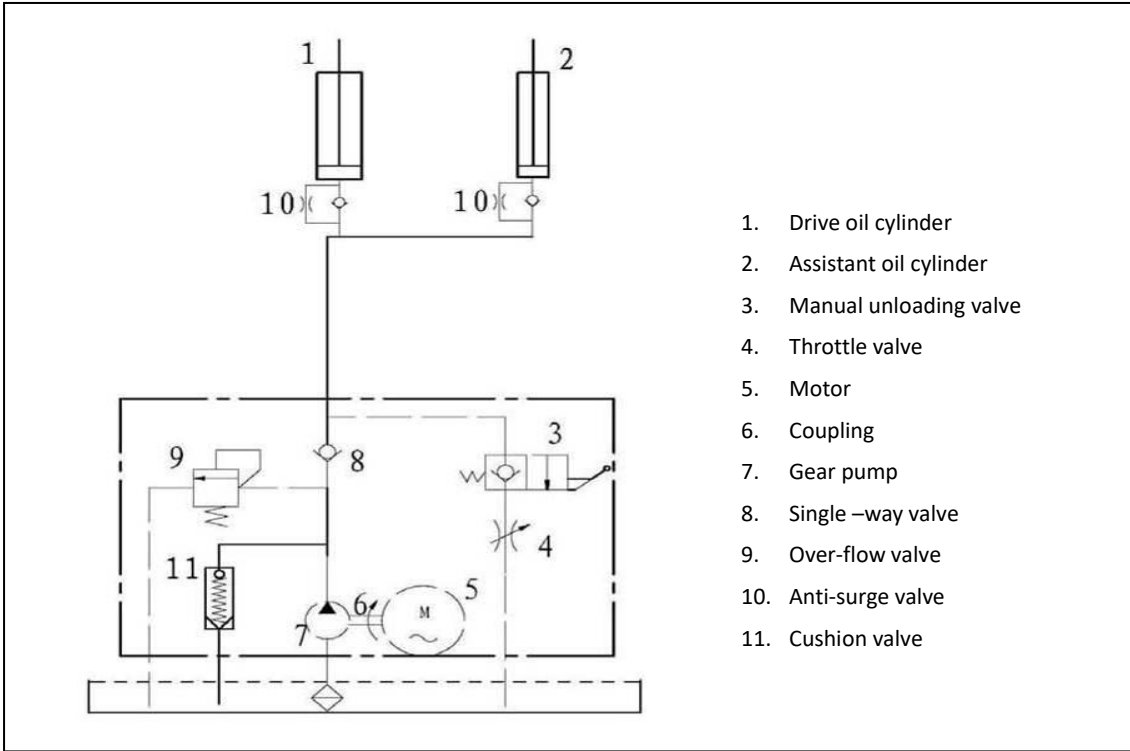

- 1. Drive oil cylinder
- 2. Assistant oil cylinder
- 3. Manual unloading valve
- 4. Throttle valve
- 5. Motor
- 6. Coupling
- 7. Gear pump
- 8. Single-way valve
- 9. Over-flow valve
- 10. Anti-surge valve
- 11. Cushion valve

Annex 3, Assembly drawings

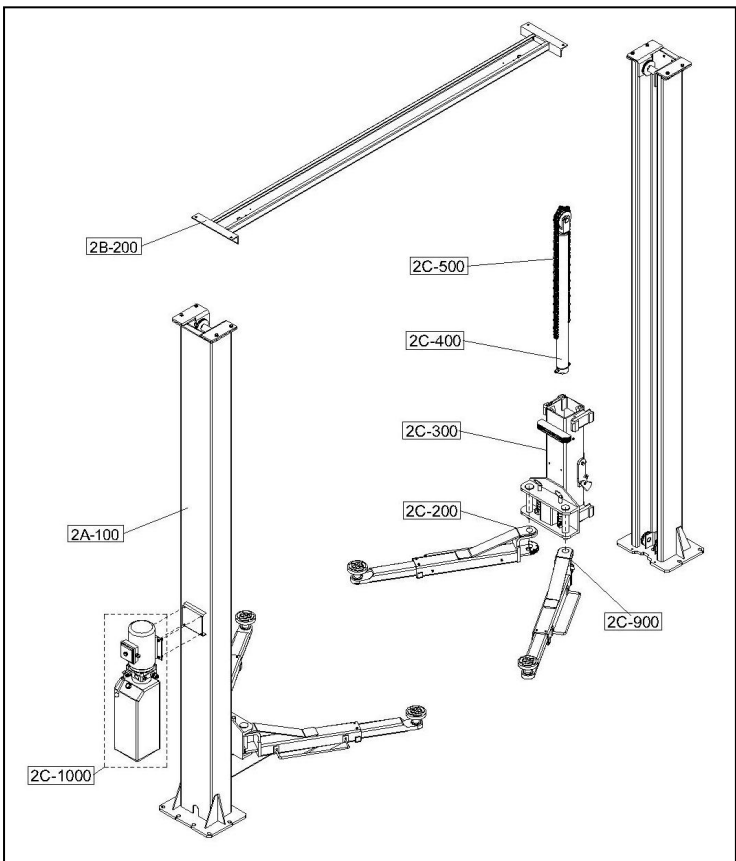

S/N	Name	Qty
2C-200	Complete lifting arm assembly	2set
2C-300	Complete carriage assembly	2set
2C-400	Complete oil cylinder	2set
2C-500	Chain	2set
2C-800	Complete control box assembly	1set
Optional		
2C-900	Complete lifting arm assembly	2set
2A-100	Complete column assembly	2set
2B-200	Complete top beam assembly	1set

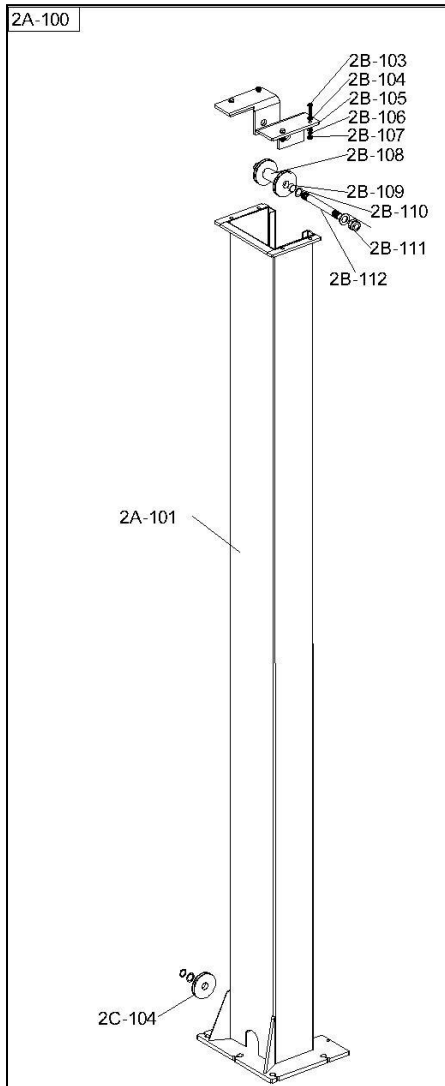

S/NN	Name	Qty
2C-104	Pulley	3 pcs
2A-101	Column	2 pcs
2B-102	Extendable column	2pcs
2B-103	Hex screw M10*30	4 pcs
2B-104	Flat washer \varnothing 12	8 pcs
2B-105	Top plate	2 pcs
2B-106	Spring washer \varnothing 12	4 pcs
2B-107	Hex nut M12	4 pcs
2B-108	Sleeve	1 pc
2B-109	Axle sleeve	2 pcs
2B-110	Flat washer \varnothing 25	2pcs
2B-111	Hex nut M20	2 pcs
2B-112	Fixed axis	1 pc

S/NN	Name	Qty
2B-201	Top plate	1 pc
2B-202	Limited switch	1 pc
2B-203	Fixed base 1	1pc
2B-204	Round steel tube	1 pc
2B-205	Fixed base 2	1 pc

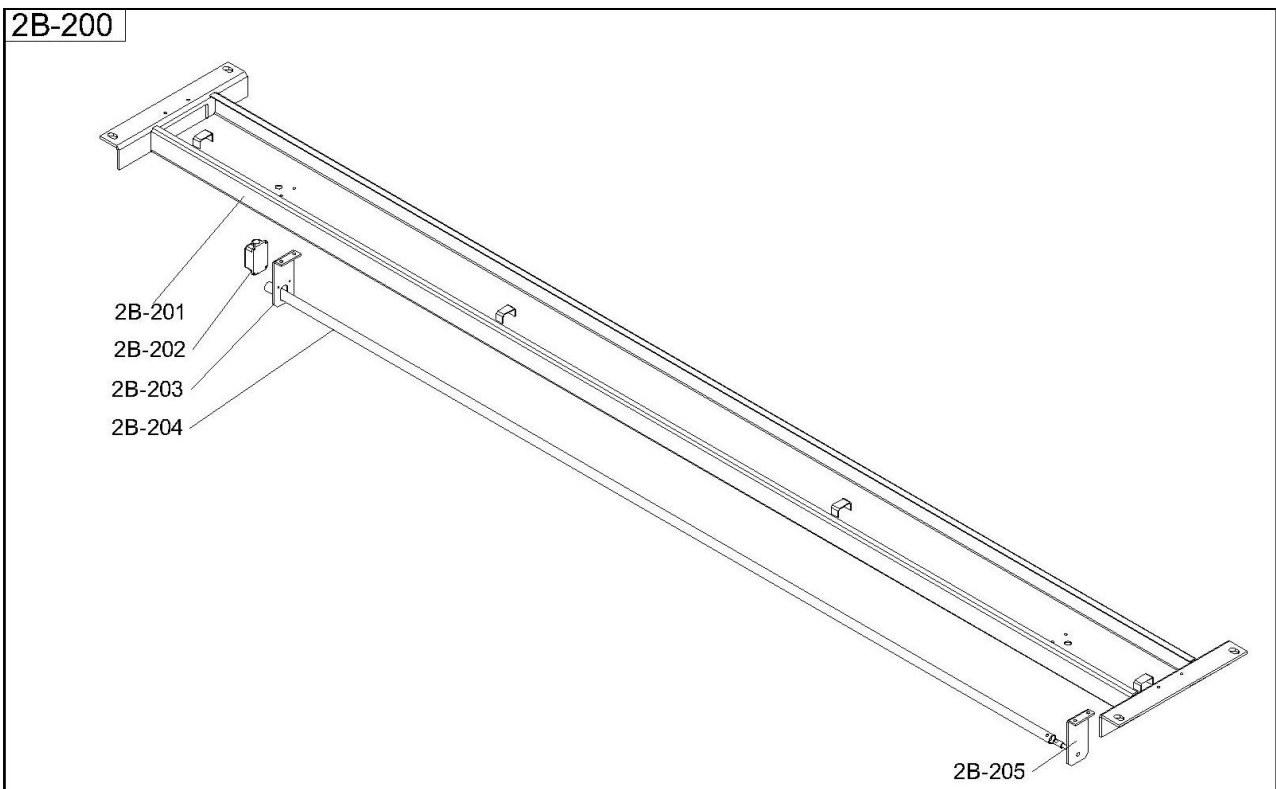

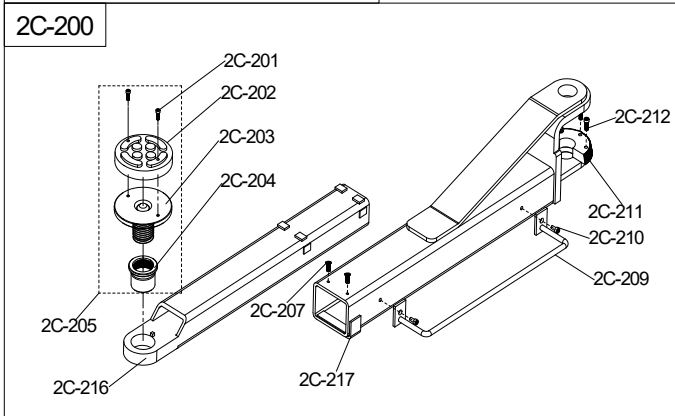
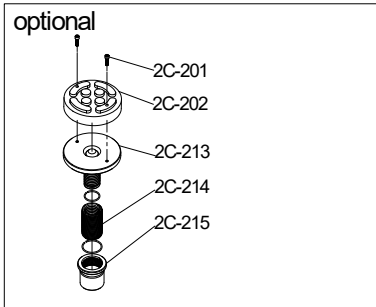

S/NN	Name	Qty
2C-201	Cross countersunk head screw	8 pc
2C-202	Rubber lifting pad 120*30mm	4 pc
2C-203	Lifting tray	4 pc
2C-204	Swivel nut	4 pc
2C-205	Complete tray assembly (2C-201,202,203,204)	4 set
2C-216	Lifting arm1 80*80*580mm	2 pc
2C-207	Cross socket head cap screw M8*12	8 pc
2C-217	Lifting arm2 100*100*575mm	2 pc
2C-209	Fender	4 pc
2C-210	Hex socket head cap screw M8	8 pc
2C-211	Semi-circle block	4 pc
2C-212	Hex socket head cap screw M8*12	12 pc
2C-213	Inside swivel nut	4 pc
2C-214	Swivel nut	4 pc

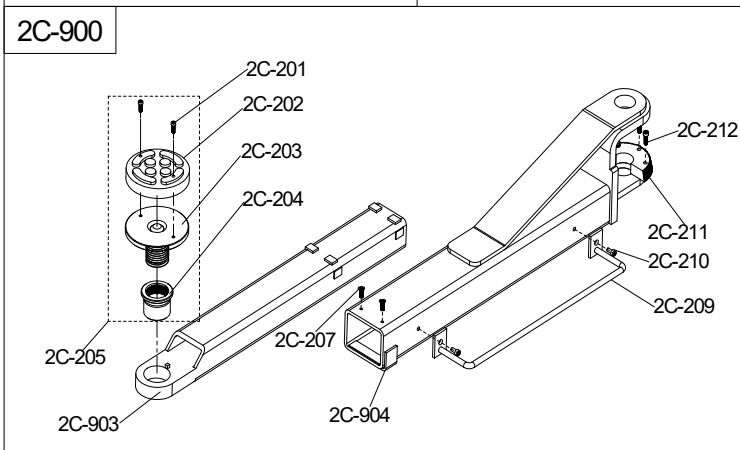
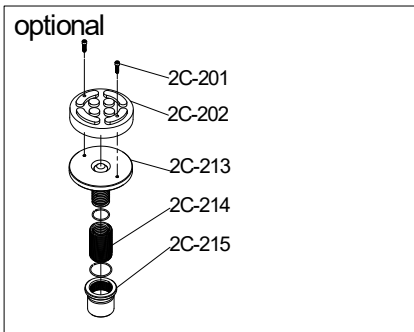

S/NN	Name	Qty
2C-903	Lifting arm3 80*80*630mm	2 pc
2C-904	Lifting arm4 100*100*625mm	2 pc

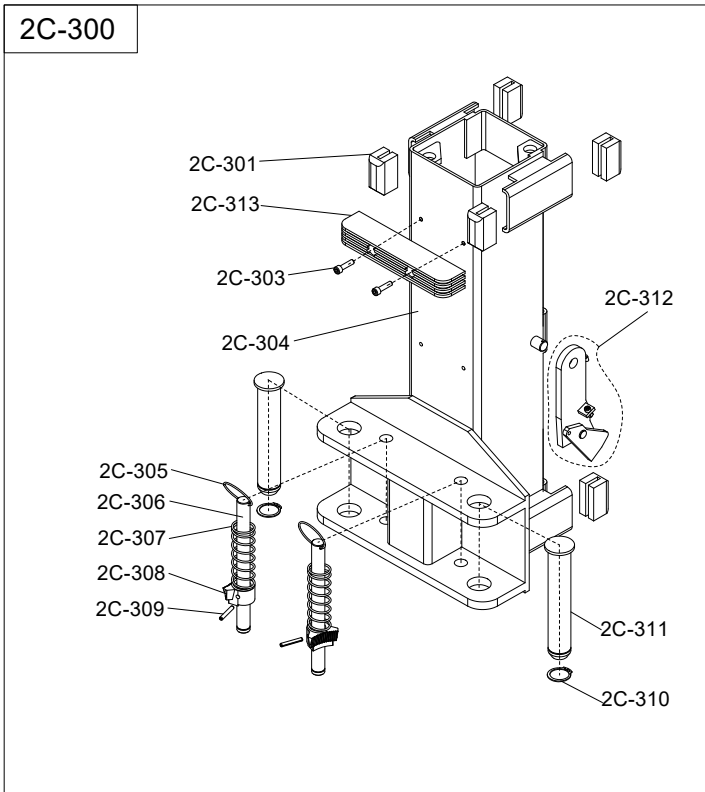

S/NN	Name	Qty
2C-301	Slider 70*37*37mm	16 pc
2C-313	Protection rubber pad	2 pc
2C-303	Hex socket head cap screw M8	4 pc
2C-304	Carriage	2 pc
2C-305	Key ring \varnothing 4*60	4 pc
2C-306	Locking shaft \varnothing 22	4 pc
2C-307	Spring	4 pc
2C-308	Teeth block	4 pc
2C-309	Elastic cylindrical pin	4 pc
2C-310	Shaft snap ring \varnothing 40	4 pc
2C-311	Pin shaft	4 pc
2C-312	Insurance device	1 set

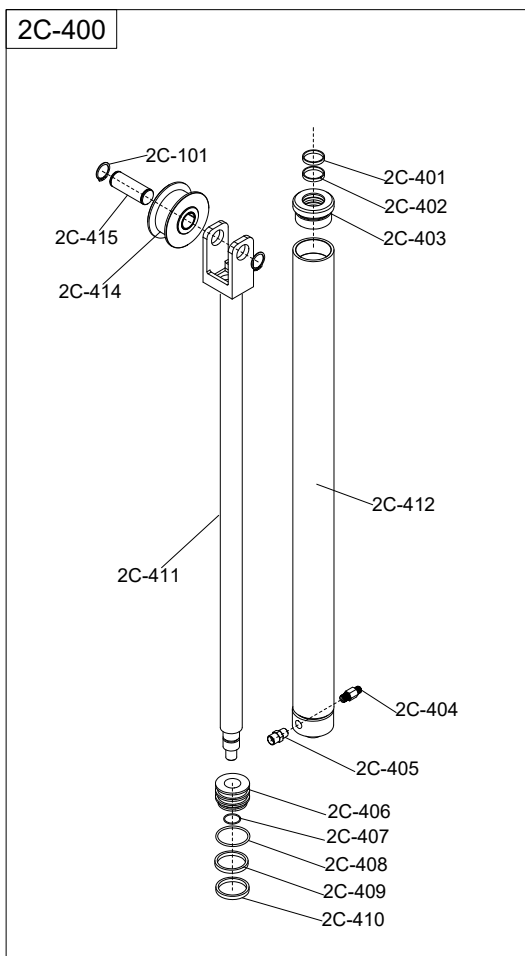

S/NN	Name	Qty
2C-401	Y-ring 48*6mm	2 pc
2C-402	Guided ring 44*10mm	2 pc
2C-403	Oil cylinder cover	2pc
2C-404	Oil hose connector	1pc
2C-405	Oil hose connector	2pc
2C-406	Piston	2pc
2C-407	O-ring 25*4mm	2pc
2C-408	O-ring 64*5.5mm	2pc
2C-409	Guided ring 63*9.2mm	2pc
2C-410	Y-ring 63*10mm	2pc
2C-411	Piston rod	2pc
2C-412	Oil cylinder	2pc
2C-414	Chain wheel	2pc
2C-415	Shaft	2pc
2C-101	Shaft snap ring \varnothing 30	4pc

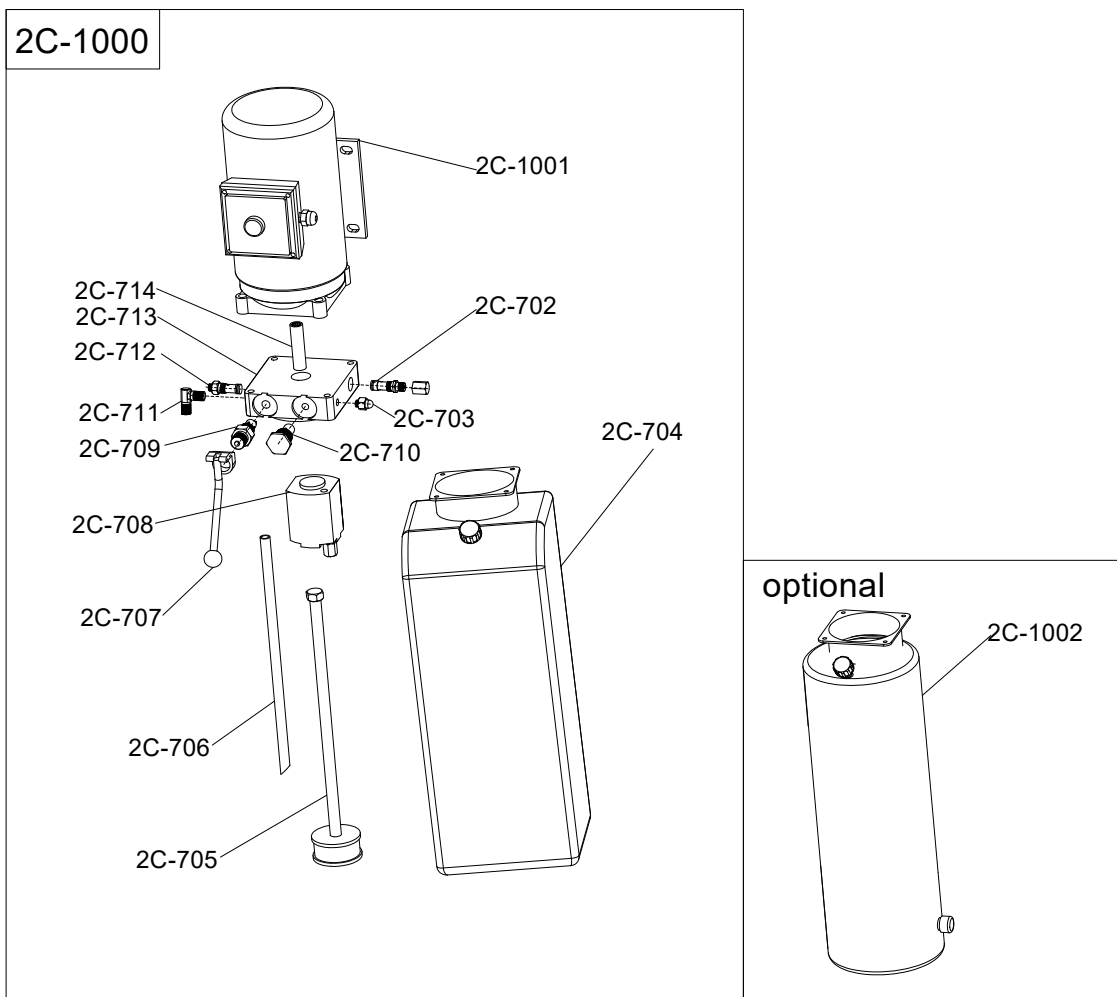

S/N	Name	Qty
2C-1001	Motor	1 pc
2C-702	Overflow valve	1 pc
2C-703	Plug	1 pc
2C-704	Plastic oil tank	1 pc
2C-705	Oil absorbing pipe	1 pc
2C-706	Oil back pipe	1 pc
2C-707	Lowering handle	1 pc
2C-7082C-7	Gear pump	1 pc
2C-709	Unloading valve	1 pc
2C-710	One-way valve	1 pc
2C-711	Oil hose connector	1 pc
2C-712	Throttle valve	1 pc
2C-713	Valve seat	1 pc
2C-714	Annectent spinde	1 pc
2C-1002	Iron oil tank (optional)	1 pc

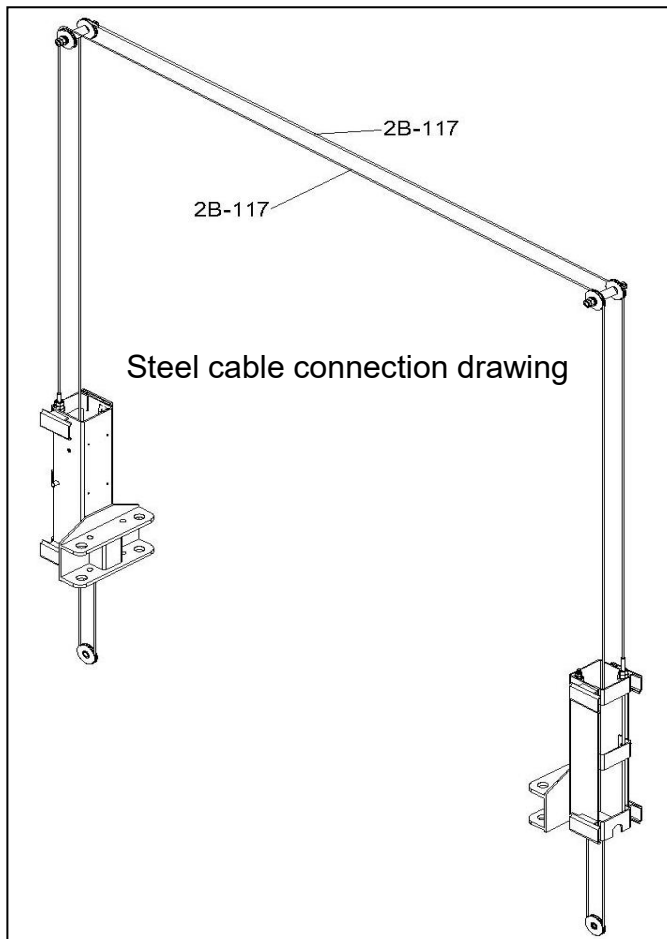

S/N	Name	Qty
2B-117	Steel cable	2 pcs

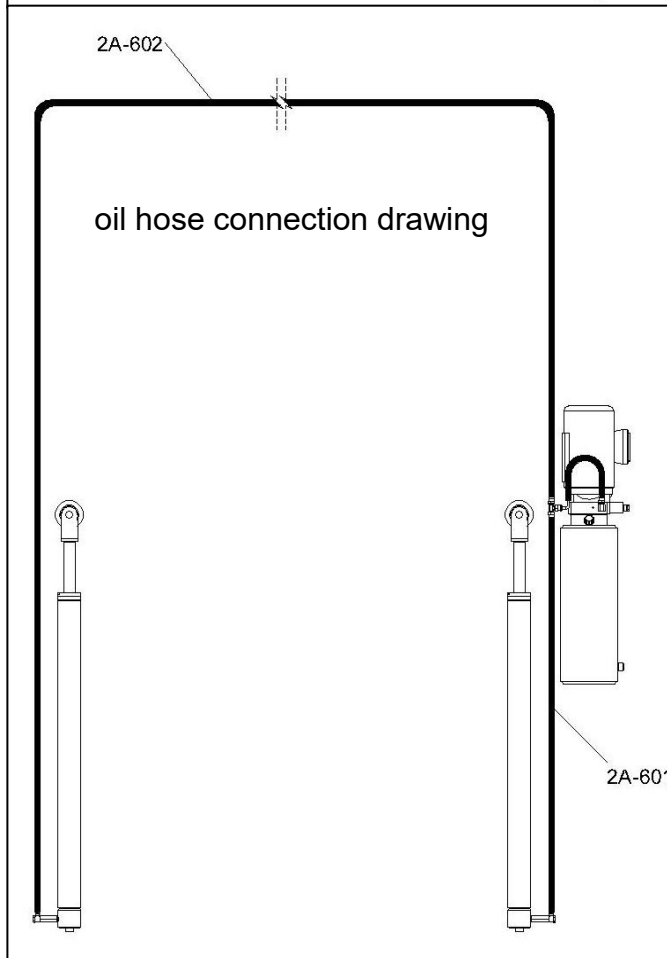

S/N	Name	Qty
2A-601	Short oil hose	1 pc
2A-602	Long oil hose	1 pc