

# 71.040.4PL

## CAR LIFT INSTRUCTION & MAINTENANCE MANUAL



**Jimy Industrial Pty Ltd**  
**5 Cord St**  
**Dudley Park, 5008**  
**Ph: (08) 8269 9700**  
**W: [www.jimytools.com.au](http://www.jimytools.com.au)**  
**E: [sales@jimytools.com.au](mailto:sales@jimytools.com.au)**



Read this entire manual carefully and completely before installation or operation of the lift

**INDEX**

**1.SAFETY INSTRUCTIONS.....**

- 1.1 Statement
- 1.2 Qualified operator and instructions for use
- 1.3 Notes
- 1.4 Warning Signs
- 1.5 Noise standard

**2.INTRODUCTION.....**

- 2.1 Product description
- 2.2 Technical parameter
- 2.3 Main structure of the machine

**3.INSTALLATION.....**

- 3.1 Before installation
  - 3.1.1 Tools and equipments needed
  - 3.1.2 Ground requirement
  - 3.1.3 Check accessories
- 3.2 Precautions during installation
- 3.3 Installation steps
- 3.4 Notes after installation

**4.OPERATION.....**

- 4.1 Operating instructions
- 4.2 Operation flow chart
- 4.3 Instructions for use

**5.TROUBLE SHOOTING.....**

**6.MAINTENANCE.....**

**7.ENCLOSURE.....**

- Enclosure 1 Packing list
- Enclosure 2 Overall diagram
- Enclosure 3 Space required
- Enclosure 4 Hydraulic diagram
- Enclosure 5 Wiring diagram

## SAFETY INSTRUCTIONS

### 1.1 Statement

- We will give the user one-year warranty of quality for the machine. If something wrong with the machine within the term of service, we will repair or replace the product according to the user's demand. The manufacturer will not take any responsibility for improper installation and operation, overload running, wrong concrete ground (that can not meet the requirements in the manual), normal mechanical abrasion and insufficient maintenance.
- The lifting machine is designed for lifting vehicles and does not allow any other use. Neither the dealers nor we are liable for the accidents and damage caused by the machines for other purposes..
- Be sure to pay attention to the tonnage mark on the machine and shall not attempt to lift the vehicle beyond the rated lifting weight.
- Please read the manual carefully before installation and operation of the lifting machine so as to avoid any loss of property or even personal injury caused by improper operation.
- In the absence of the manufacturer's permission, no user may alter the control and other mechanical parts of the machine without permission.

### 1.2 Qualified operator and instructions for use

1. 2. 1 Professional trained personnel can operate the lift.
1. 2. 2 Electrical connections must be operated by personnel with electrical qualifications.
1. 2. 3 Laypeople shall not use lifting machines.

### 1.3 Notes

1. 3. 1 Do not install the lift on asphalt. The thickness of the concrete must meet the requirements.
1. 3. 2 Before you operate the lift, read and understand the instructions for safety operation carefully.
1. 3. 3 Customers do not have special needs customized, lifts are generally not used outdoors.
1. 3. 4 Hands and feet away from the lift's moving parts, when the machine falling, remove the hands and feet, to avoid being hurt.
1. 3. 5 Professional trained personnel can operate the lift.
1. 3. 6 The operator is not allowed to wear fat clothing so as not to be caught in the moving parts during the lifting of the machine.
1. 3. 7 The lifting machine must be kept clean and tidy and should not be piled up so as not to cause accidents.
1. 3. 8 The lifter is designed to lift the vehicle as a whole rather than a part; do not attempt to lift more than the rated lifting weight of the vehicle.
1. 3. 9 Work under the car, make sure the safety of the lift in occlusal state.
1. 3. 10 Lift the lifting pad must be placed in the vehicle manufacturers recommended position, and then slowly lift the vehicle, to determine the smooth, no tilt, tipping, fall off in order to lift to the desired height.
1. 3. 11 Check the parts for damage at any time, check the synchronism of the machine and the flexibility of the moving parts, and pay attention to the regular maintenance. Once the abnormal situation is found, stop using and contact the dealer immediately.
1. 3. 12 Please lowest the machine after operation.
1. 3. 13 The components of the lift shall not be altered without the manufacturer's permission.
1. 3. 14 If the machine is not used for a long time, the user needs

A. Cut-off power      B. Emptying hydraulic fluid      C. The moving parts are lubricated with hydraulic oil.

**Attention:**

The parking car lift belongs to high-risk products, installation or improper operation, or modify the mechanical components, are likely to cause injury or death of the operator, read the instructions carefully and strictly in accordance with the requirements of work, and do not randomly discharge liquid, protect the surrounding environment.

**1.4 WARNING SIGNS**

All safety warning signs presented on the machine with the purpose to draw the operator's attention from dangerous or unsafe situations. The labels must be kept clean and they have to be replaced if detached or damaged. Read the meaning of the labels carefully and memorize it.

 <p><b>WARNING</b></p> <p>Clear area if vehicle is in danger of falling.</p>	 <p><b>WARNING</b></p> <p>Remain clear of lift when raising or lowering vehicle.</p>	 <p><b>CAUTION</b></p> <p>Lift to be used by trained operator ONLY.</p>	 <p><b>CAUTION</b></p> <p>Authorized personnel only in lift area.</p>
 <p><b>WARNING</b></p> <p>Keep clear of pinch points when lift is moving.</p>	 <p><b>WARNING</b></p> <p>Keep feet clear of lift while lowering.</p>	 <p><b>SAFETY INSTRUCTIONS</b></p> <p>Read operating and safety manuals before using lift.</p>	 <p><b>SAFETY INSTRUCTIONS</b></p> <p>Proper maintenance and inspection is necessary for safe operation.</p>
 <p><b>WARNING</b></p> <p>Do not override self-closing lift controls.</p>	 <p><b>WARNING</b></p> <p>Check wheel to prevent vehicle movement.</p>	 <p><b>SAFETY INSTRUCTIONS</b></p> <p>Do not operate a damaged lift.</p>	<p>The messages and pictographs shown are generic in nature and are meant to generally represent hazards common to all automotive lifts regardless of specific style.</p> <p>Funding for development and validation of these labels was provided by the Autotive Lift Institute, P.O. Box 85 Cortland, NY 13045.</p> <p>Replacement label sets may be obtained from the original lift manufacturer and ALI's member companies. They are protected by copyright.</p>

**1.5 Noise standard**

Lifting machine noise should be less than 75dB, for your health sake, it is recommended to put a noise meter in your work area, observe the noise of the lifting machine at any time.

## INTRODUCTION

### 2.1 Product description:

A: Four parking lift is composed of a main side column, beam, bridge, bridge, safety mechanism, hydraulic cylinder, power unit, control box (optional) and other major components.

B: The power unit is switched on, the gear pump operation, promote the hydraulic oil cylinder piston rod, wire rope driven mobile cylinder movement process, because the steel wire rope traction between bridge decks and beams, so as to realize the lift up and down movement, and then achieve the purpose of lifting.

C: The insurance agency safety lock block in each process will automatically rise and bite the column within the rack together, make sure not because the hydraulic system failure caused by falling.

### Security structure diagram:

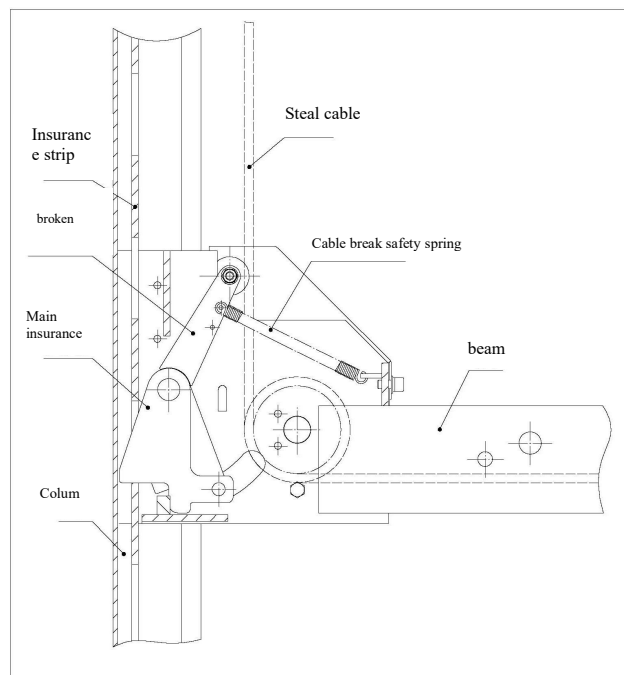

### 2.2 Technical parameter

Type	Lifting capacity	Rise / fall time	Lifting Height	Total height	Total width	Width between
	4000kg	《60s	2210mm	2490mm	2780mm	5939mm

### 2.3 Main structure of the machine

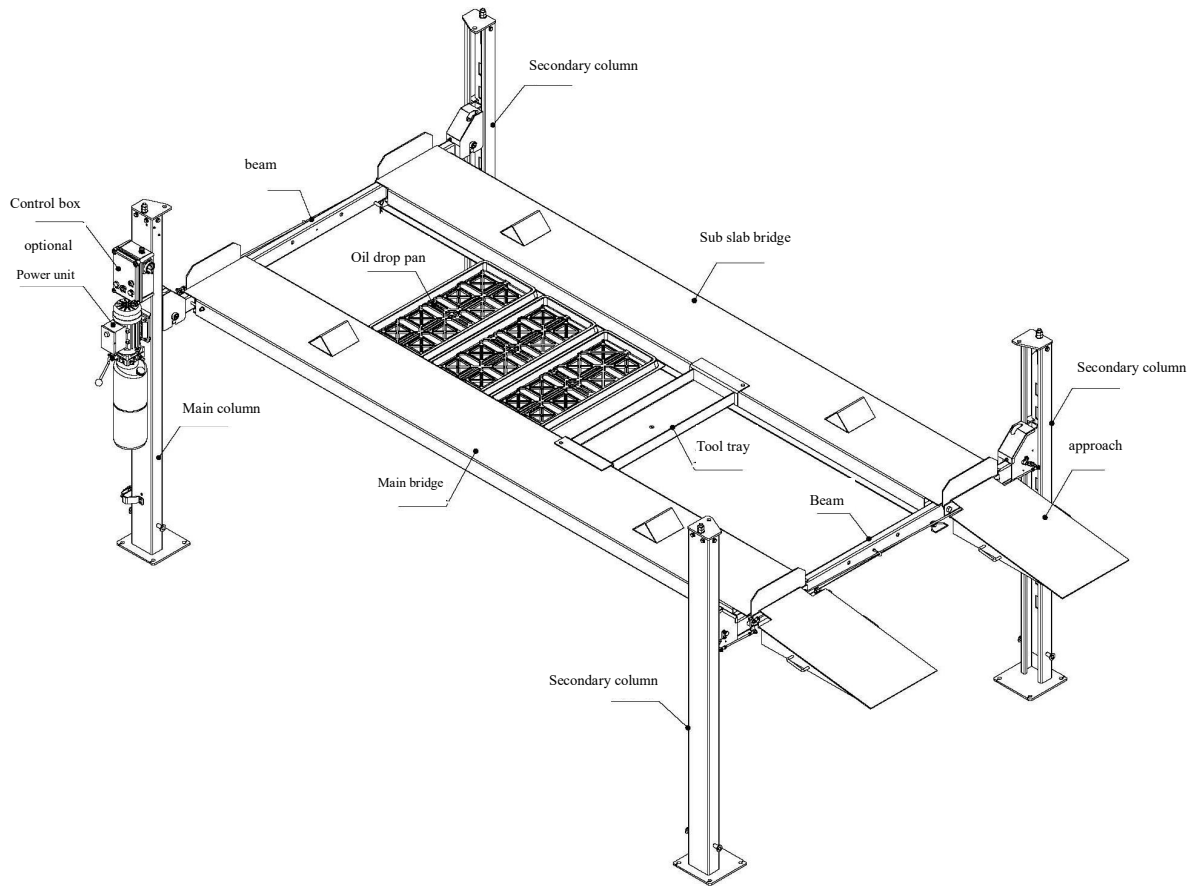

## INSTALLATION

### 3.1 Before installation

#### 3.1.1 Tools and equipments needed

1.Lifting equipment 1 piece, 2.Antiwear hydraulic oil 10L,3.Electric drill,4.chalk,5.Tape,6.Magnet sag,7.  $\Phi$  15mm horizontal pipe 8 m ,8.Open spanner 1 set,9.Inner hexagon spanner 1 set

10.A cross screwdriver ,11.An one word screwdriver,12.A needle nose pliers, 13.  $\Phi$  17,  $\Phi$  19,  $\Phi$  22 Socket wrench each 1,14,Hammer 1 pieces (4 pounds),15.Circlip pliers 1 piece

#### 3.1.2 Ground requirement

The car lift must be installed on the concrete ground level strong, concrete strength is more than 3000psi, the error is less than 5mm, the minimum thickness of not less than 300mm. in the new pouring concrete need maintenance 20 days above.

#### 3.1.3 Check accessories

Open the package and check for missing parts in accordance with attachment 1 (complete machine packing list). Once found, contact the distributor or the manufacturer immediately. If leakage is found, installation is still performed,distribute shall not be held responsible and shall not be settled free of charge.

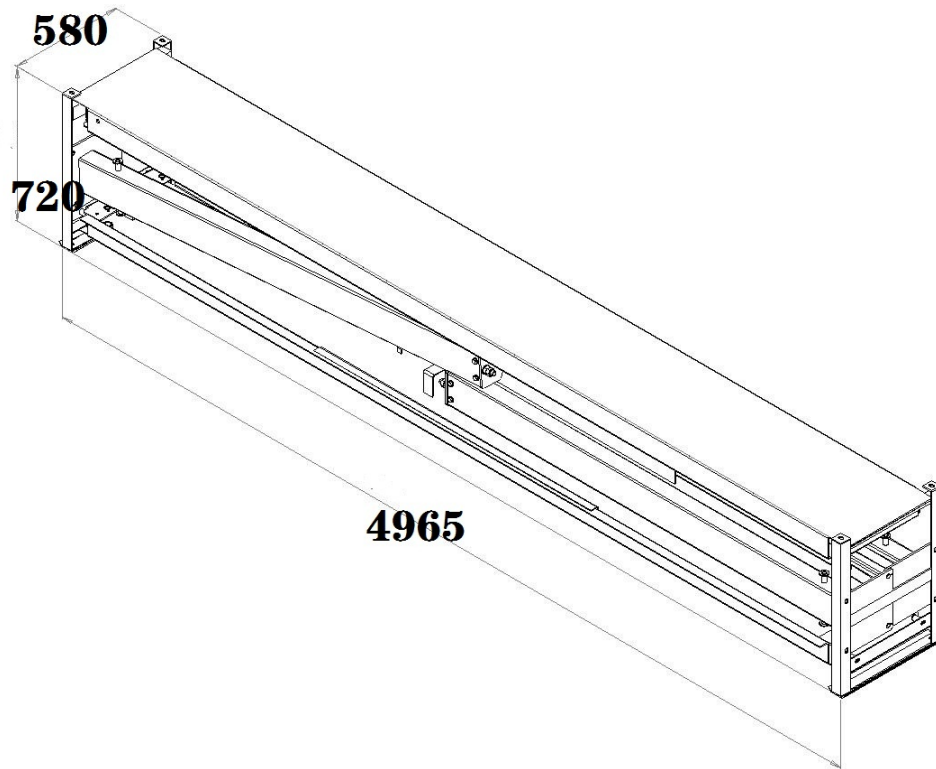

**Packing dimension drawing**

### **3.2 Precautions during installation**

- ▲ During installation, please observe that the two upright columns are parallel and vertical to the ground, and shall not be tilted.
- ▲ hydraulic hose and steel cable connection, the joint must be connected in place, so as to avoid oil leakage and steel cable loose.
- ▲ All bolts and nuts must be tightened to ensure fastening.
- ▲ No vehicles shall be placed during the test.

### **3.3 Installation steps**

#### **Step 1: Choose the suitable place:**

The lift is for indoor use only. It is installed on strong concrete, not installed on the expansion joint of the cement ground, and shall not be installed on the ground floor of the two or high floor without the permission of the relevant building personnel.

#### **Step 2: Determine the installation position and lift the hoist to the installation site with a crane.**

#### **Step 3: Disassembly package**

<1>: The pre placed wood on the ground (wood thickness greater than 100mm), crane for packaging side below the bridge plate is placed on wood, the purpose is to let off the ground at the bottom of the packing frame.

<2>: Remove the packing:

<3>: Remove the connecting screws between the main bridge board and the packing rack. Hang the main bridge board with the crane and put it in the free space.

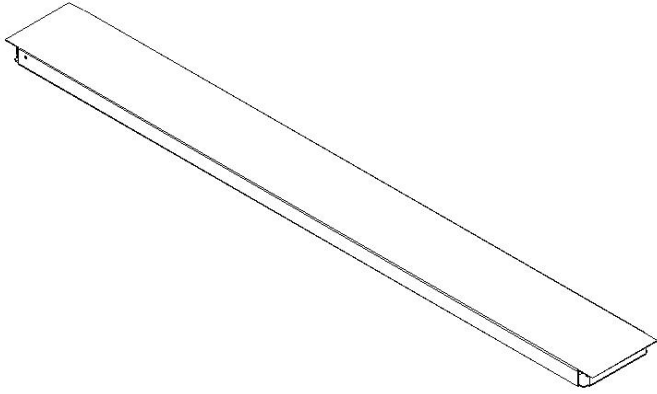

Main bridge plate 1 pieces

<4>:Remove the packing bags, take A:2 approach spans, B:3 tubing, C:1 tool plates, D:1 power units, E:1 parts cases, and put them in the free space.

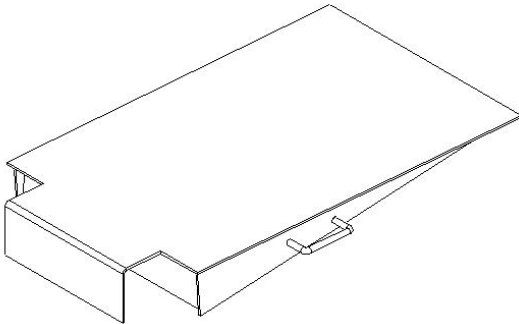

Approach spans 2 pieces

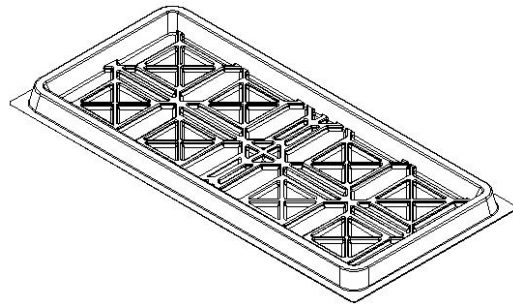

Oil drop pan 3 pieces

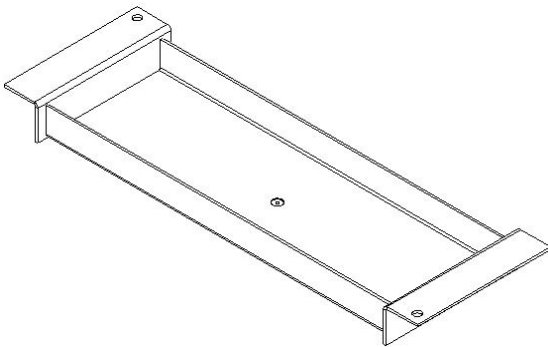

Tool tray 1 piece

<5>:Remove the belt and remove the screws from the main and secondary posts and the packing frame. Take the main and the auxiliary Posts off and put them in the free space

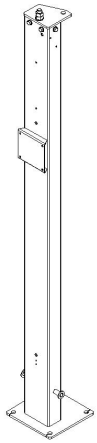

Main column 1 pieces (with motor board)

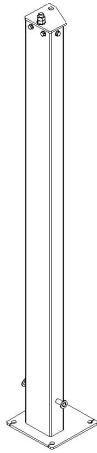

Secondary column 2 pieces

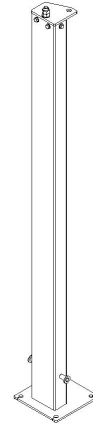

Secondary column A 1 pieces

<6>:Take out: A: beam 2, B: insurance mechanism is connected with the 1 sets of C components before and after blocking 4, D: 4 E: dashboard baffle, baffle tire 4, F mobile component 4, put it in a free place

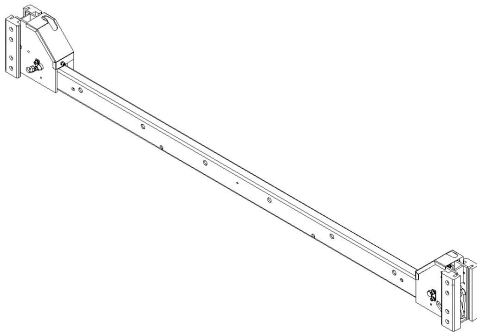

Beam 2 pieces

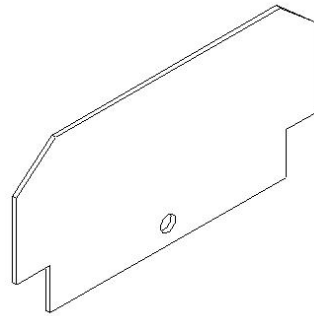

Before and after blocking 4 pieces

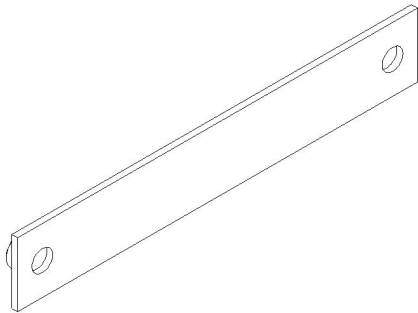

Dashboard 4 pieces

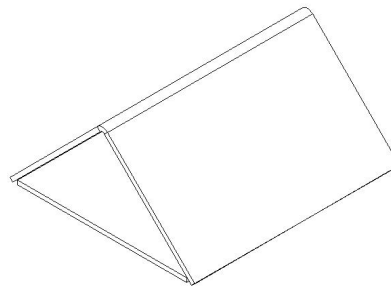

Block the tyre bracket 4 pieces

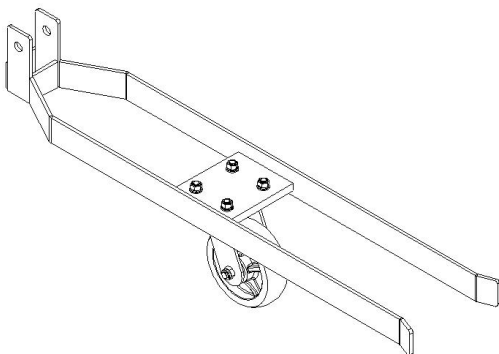

Moving components 4 pieces

<7>. The demolition of the bridge plate and side packing frame screws, remove the packing frame, crane for bridge side away, moved to the vacant

places.

**Step 4: Install column and beam:**

<1>: Remove main and auxiliary column roof and insurance bar as follows:

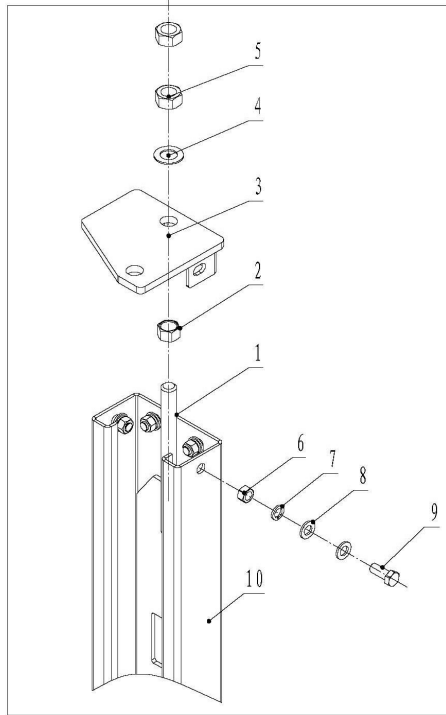

1.Column safety strip, 2.M20 custom nut, 3.Column roof, 4.M20 flat pad, 5.M20 nut, 6.M12 nut, 7.M12 spring washer, 8.M12 flat pad, 9. M12\*30 six point screw, 10.column

<2>: Mark the standing points of the four posts with tape measure and chalk, make sure the two diagonals are the same length.

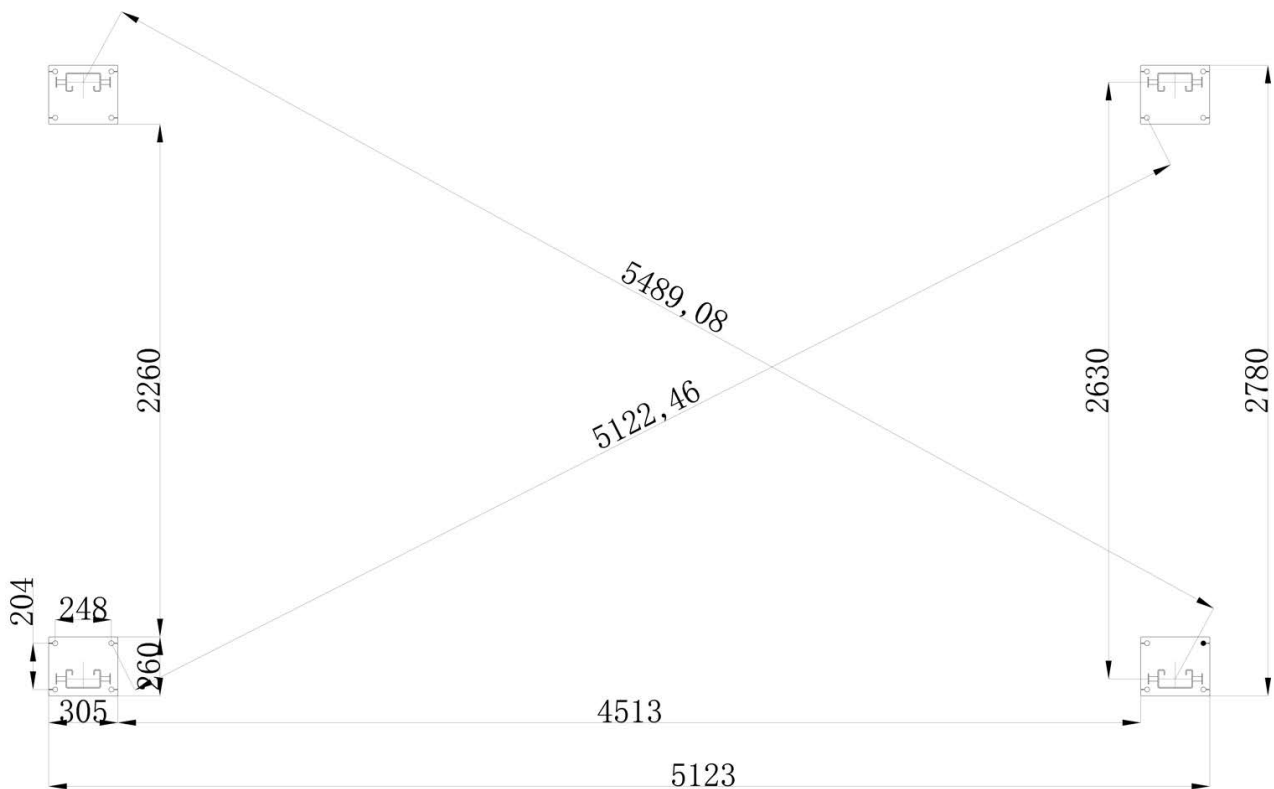

<3>Position the column with the retaining tire support and place the column upright on the ground, as shown below.

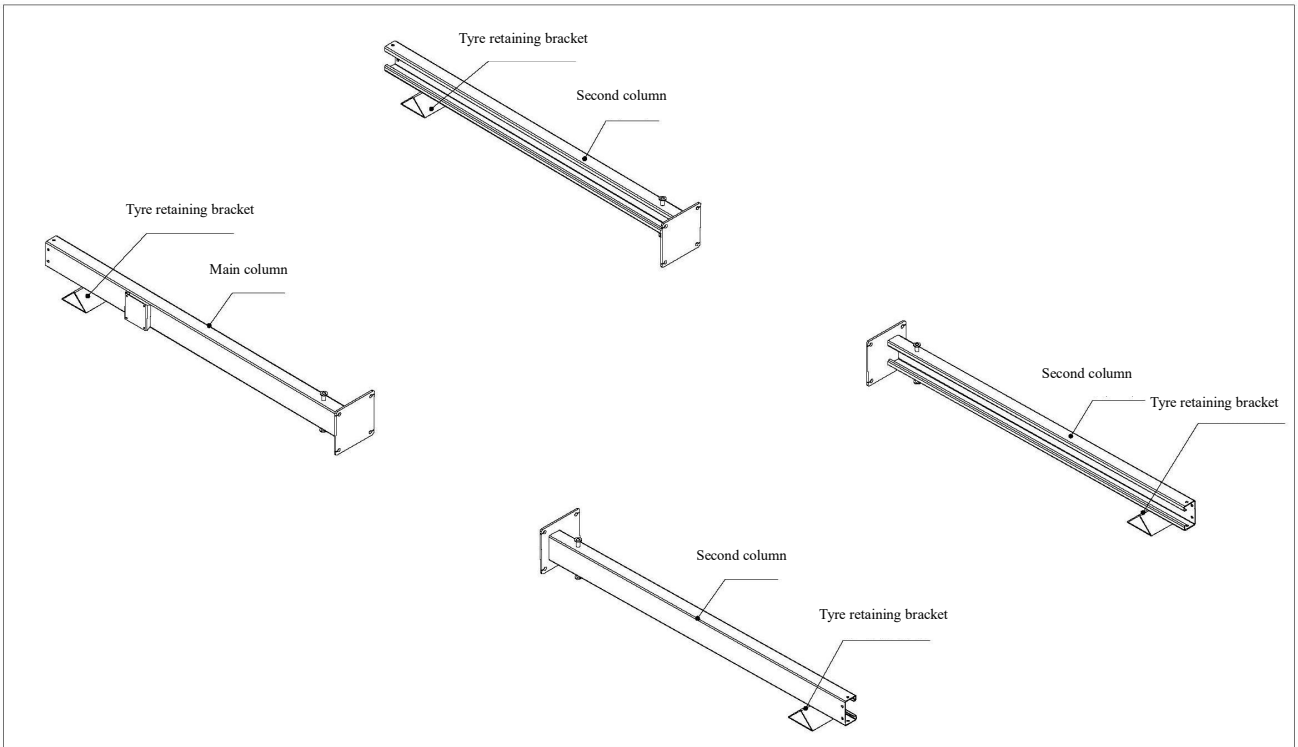

<4>:Load the cross member in the column, as shown in the following figure. (Notice: when installing the crossbeam, pay attention to the direction of the cross member)

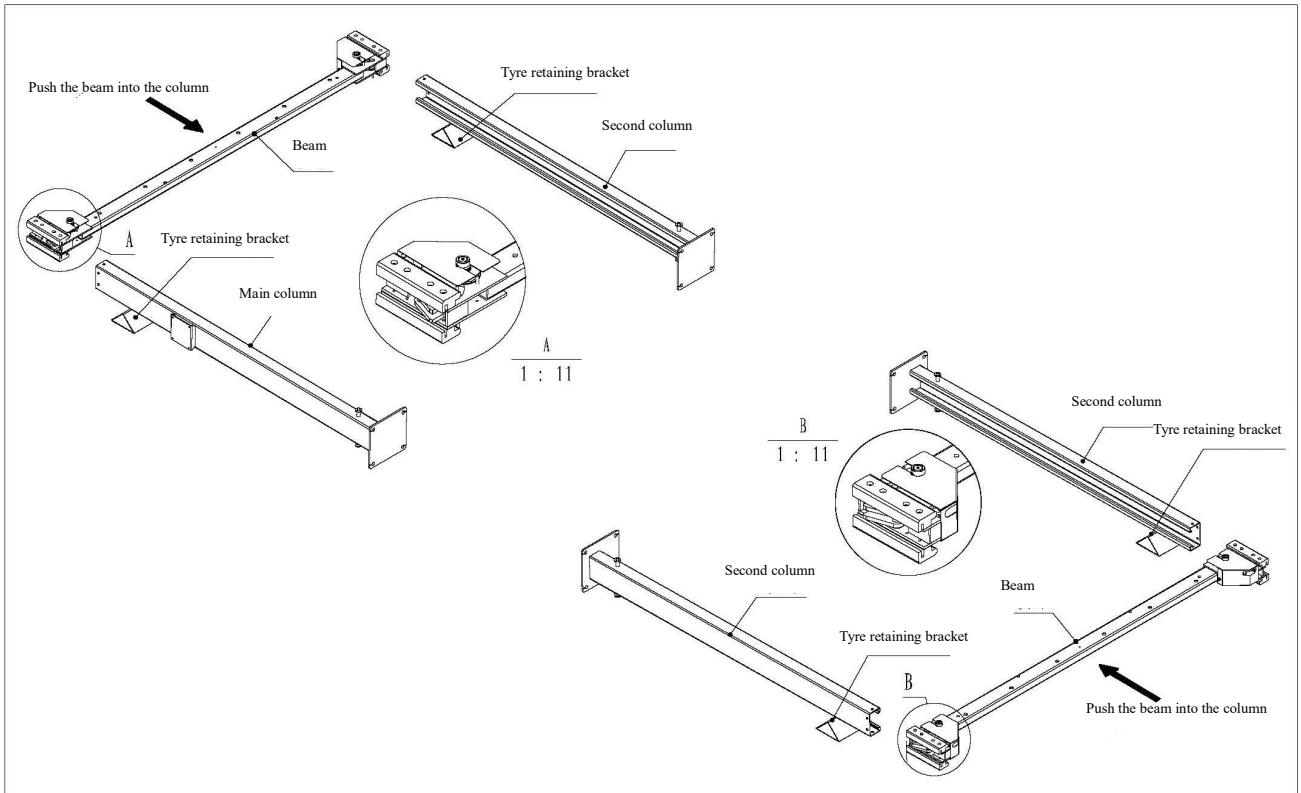

<5>:Install the roof of the column, as shown in the following figure:

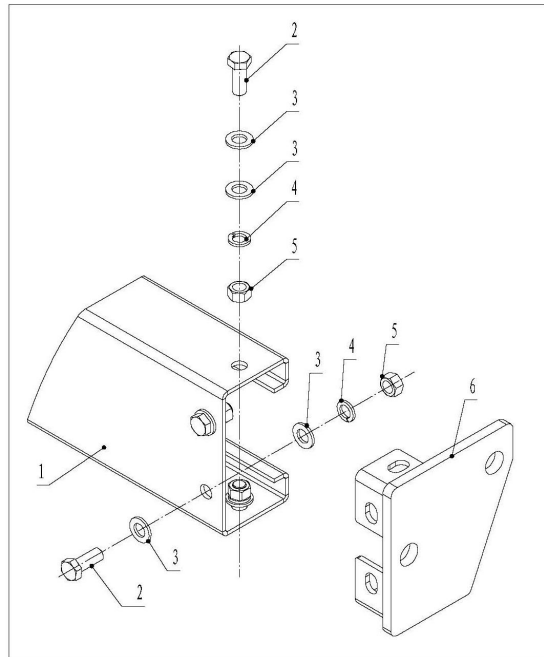

1.Column , 2. M12\*30 six angle screw, 3. M12 flat pad, 4. M12 cushion, 5. M12 nut, 6. top plate

<6>:Erect the upright post, as shown in the following figure.

(Note: the column erected after need to measure the relative position of four column, provide accurate size for subsequent installation of bridge)

Attention: according to the chart, pay attention to the direction of the main and auxilia ry column roof

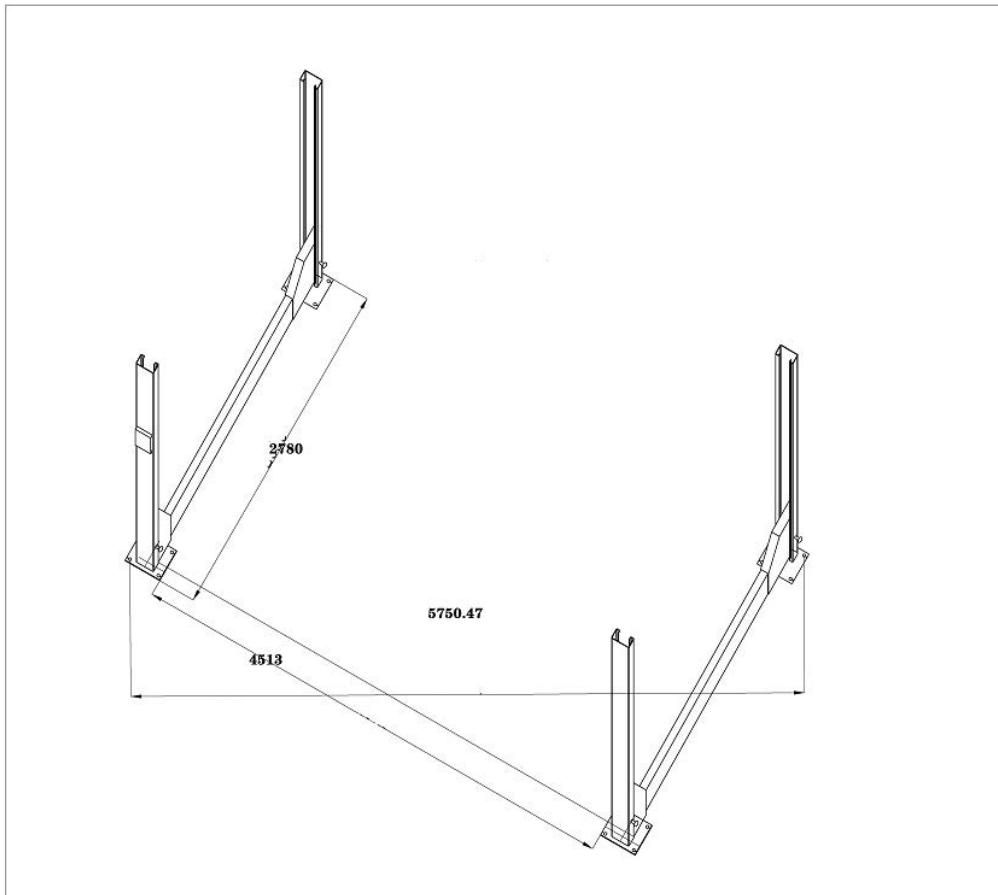

Step 5: install the control box, as shown in the following picture. (optional)

Step 6 : Install the upper limit switch, as shown in the following figure. (optional)

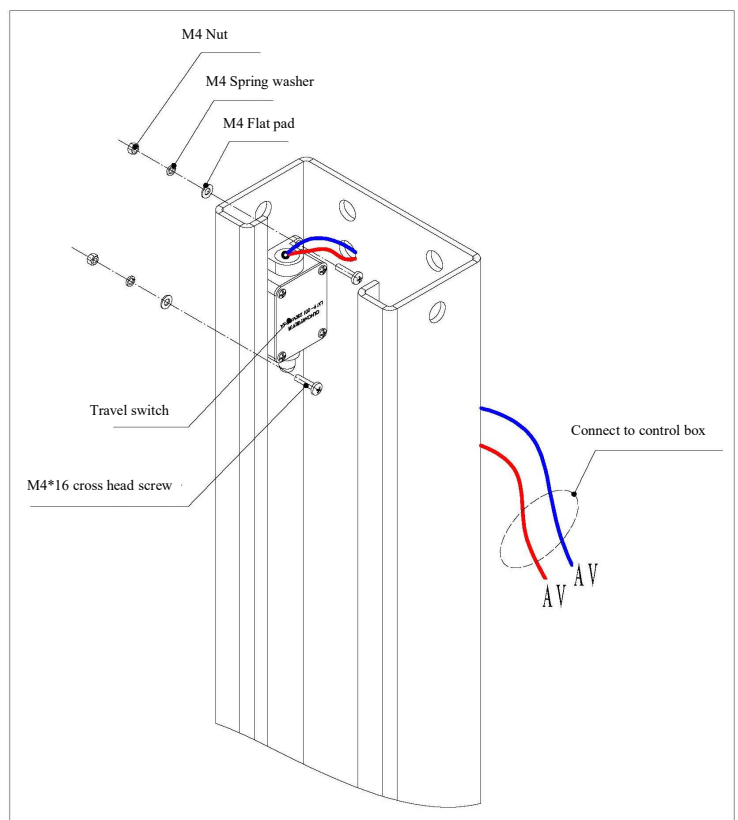
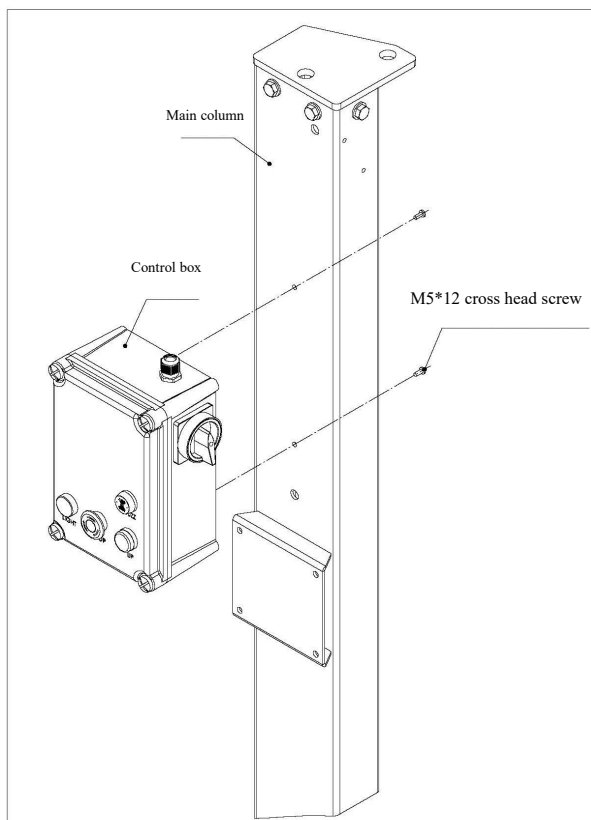

**Step 7: Install the two drop switch, as shown in the following figure. (optional)**

**Step 8: Install the insurance bar as shown in the following picture.**

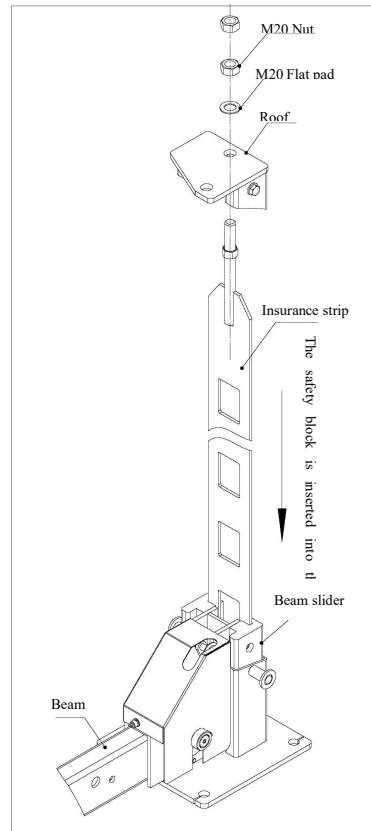
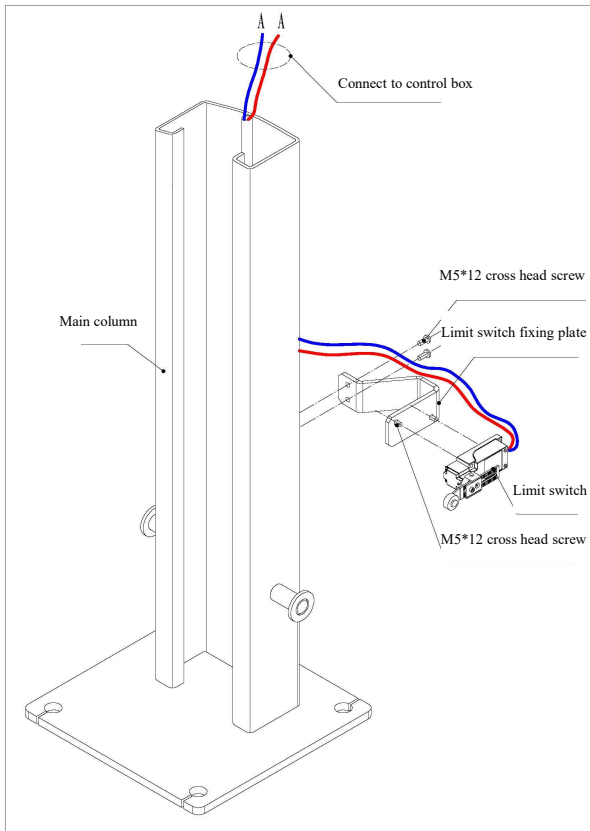

Note: if the customer requirements: A: control box, B: limit switches, C: two decreased, then the eighth step is necessary after the 5,6,7 step, not in the 5,6,7 step before, or "two down" wire to install "control box" cannot be installed.

**Step 9: Installation of the main and the second deck side and dashboard bezel.**

Lock the beam in the third lock, and then the main and auxiliary table with a crane on the beam, with the M18\*110 six angle screw, spring washer, flat washer, nut "dashboard bezel", The beam and the main and auxiliary table are as follows:

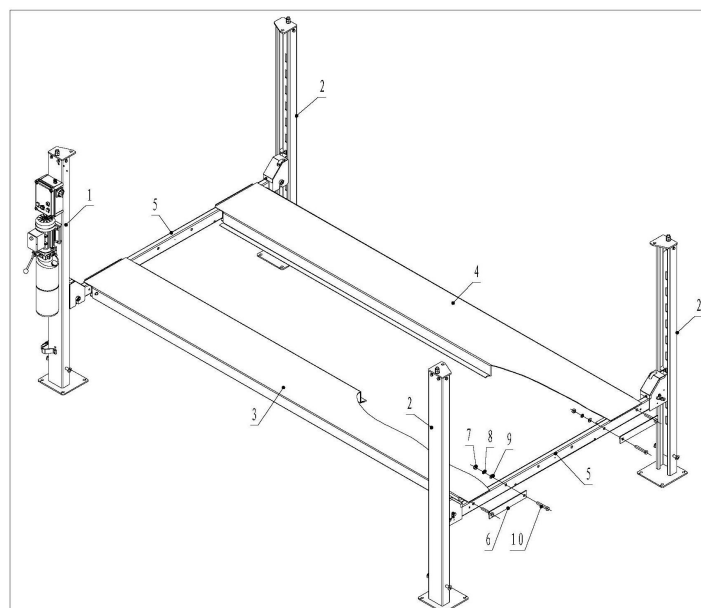

1.main column, 2. second column, 3. main board, 4. board, 5. beams, 6. dashboard bezel, 7.M18 nut, 8.M18 cushion, 9.M18 flat pad, 10.M18\*110

six screw angle

**Step 10: Install the steel cable**

Note: in the installation of steel cable, first of all, "wire rope off device", "beam shell" removed, or else the wire rope can not be installed, as shown below:

Note: when the steel cable is installed, the "wire rope removing device" and "cross beam housing" shall be installed.

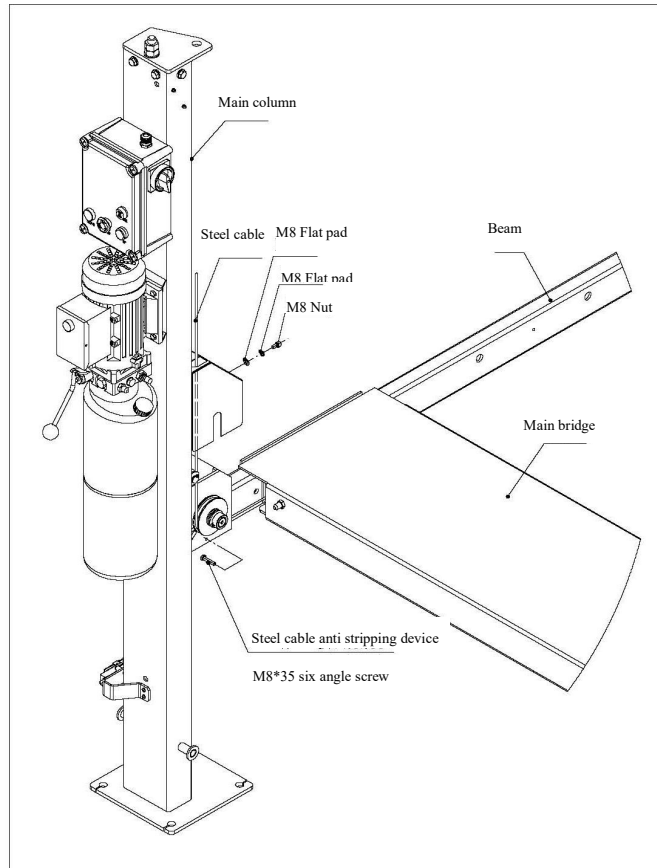

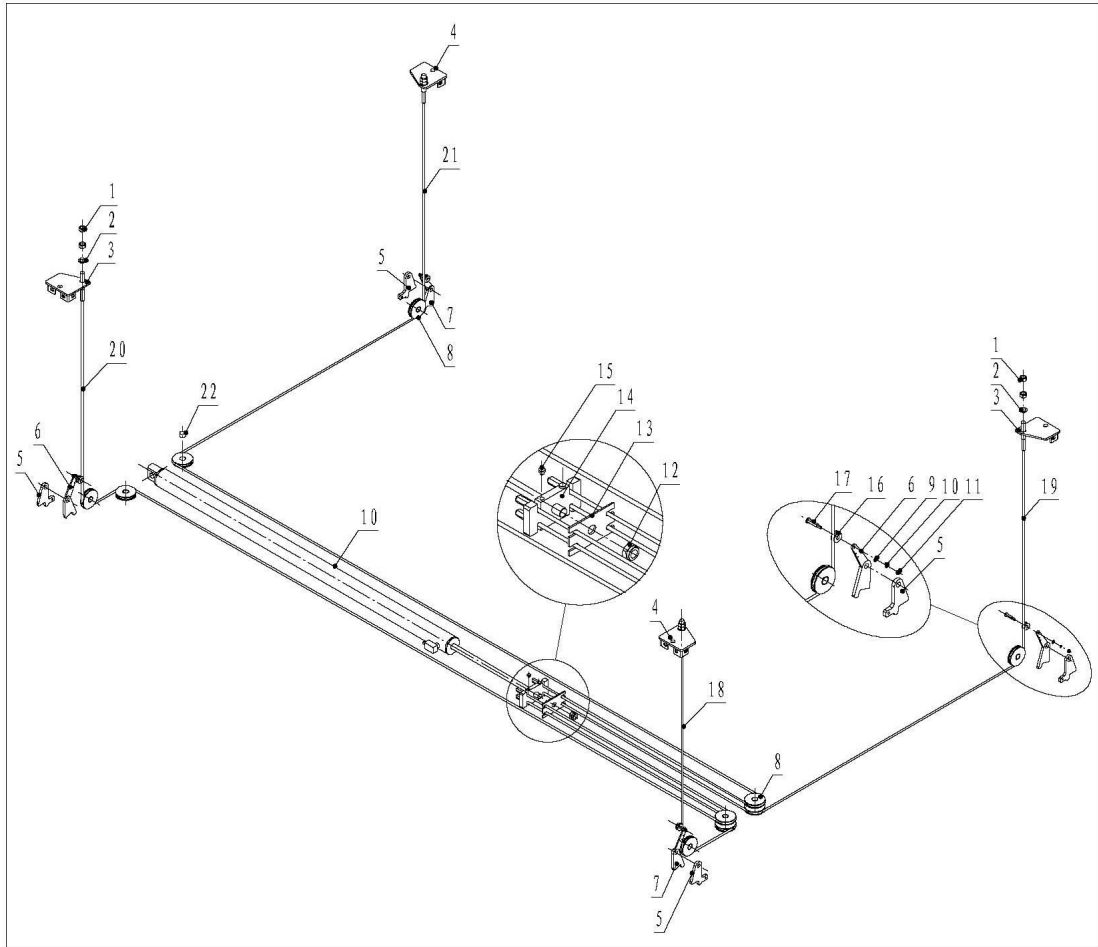

1.M20 nut, 2.M20 flat pad, 3. main, diagonal column roof, 4. pairs, diagonal column roof, 5. main safety plate, 6. main, diagonal column, rope breakage insurance,

7. second, diagonal column, rope break insurance, 8. rope pulley, 9.M8 flat pad, 10.M8 elastic pad, 11.M8 lock nut, 12.M24\*2 lock nut, 13. Steel cable holder, block 14. Steel cable holder, 15. limit cushion, 16. rope rope pulley, 17. rope break safety shaft, 18. steel wire rope 2660, 19. steel wire 4090, 20. steel wire 6730 21. Steel cable 8150, 22. oilless bearings 2519

**Step 11: Installation of insurance institutions**

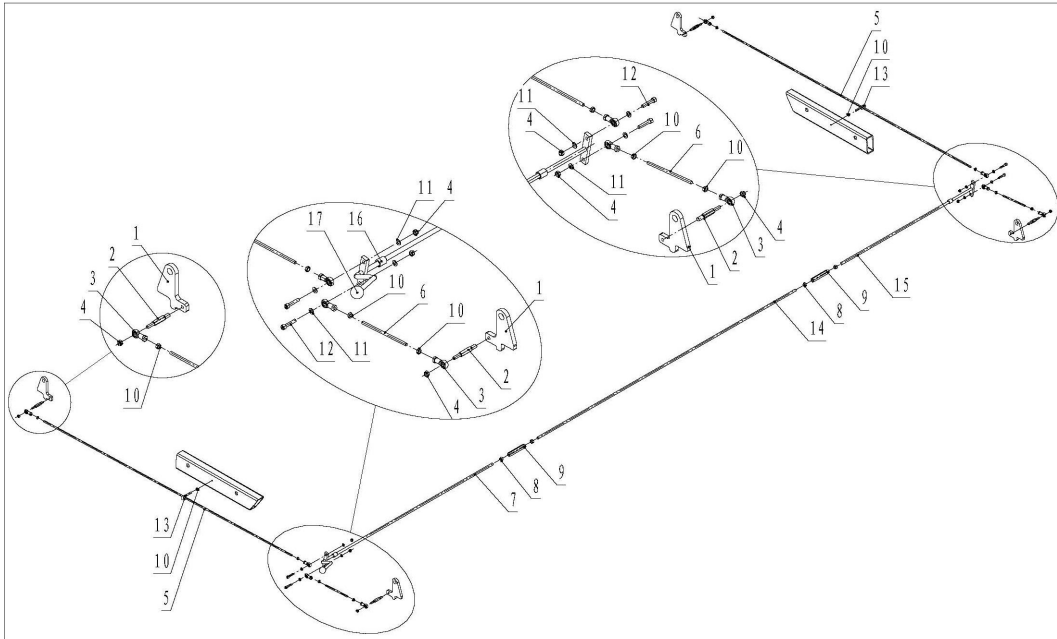

1. main insurance, 2. main insurance connection rod, 3. Vientiane earring, 4.M8 lock nut, 5. long pull rod, 6. short pull rod, 7. main safety handle, 8.M12 nut, 9. connecting rod, screw rod 10.M8 nut,.11.M8 flat pad, 12.M8\*40 six angle screw, 13. long rod fixing ring, 14. main and secondary safety handle connecting rod, 15. auxiliary safety pull rod, 16. handle isolating sleeve, 17. plastic bowls

**Step 12: Installation of oil pipe joints**

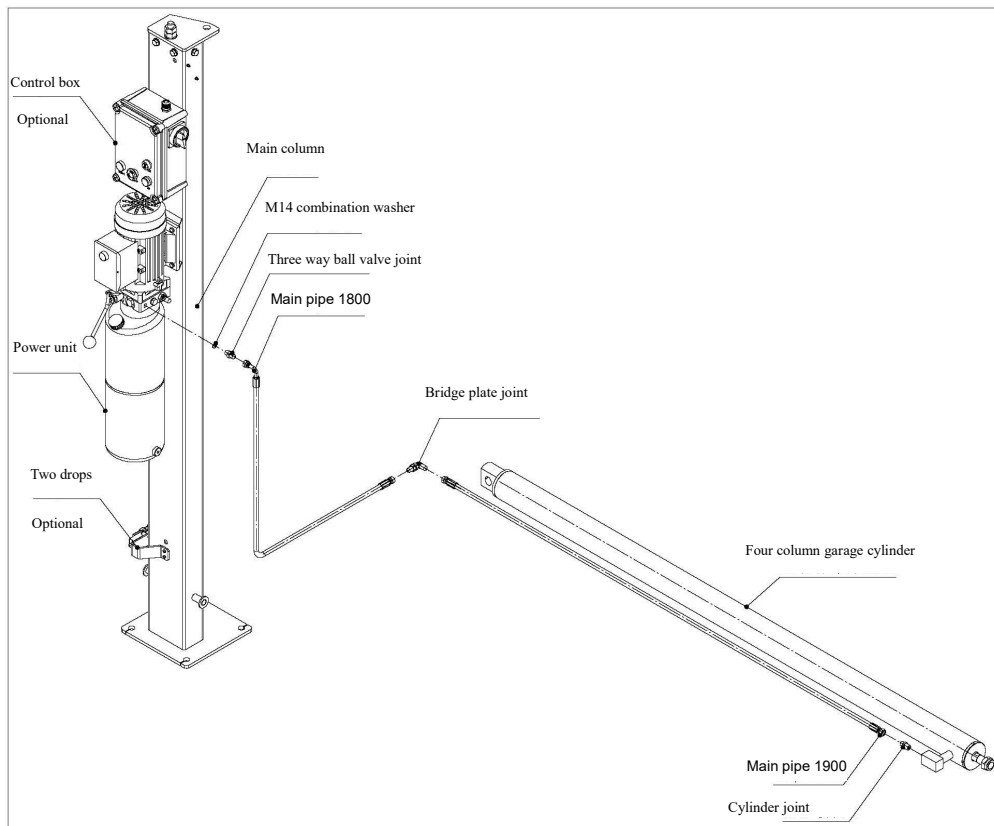

**Step 13: Install the crossbeam two times down baffle, as shown below: (optional)**

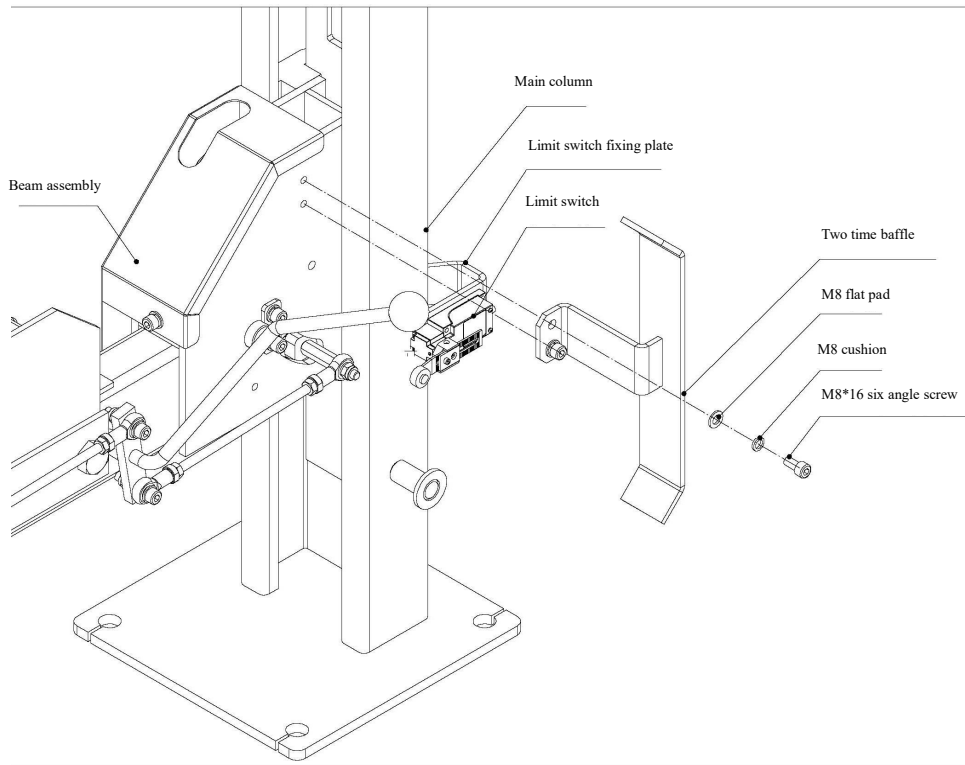

**Step 14: Installing the before and after dashboard and approach: as shown below:**

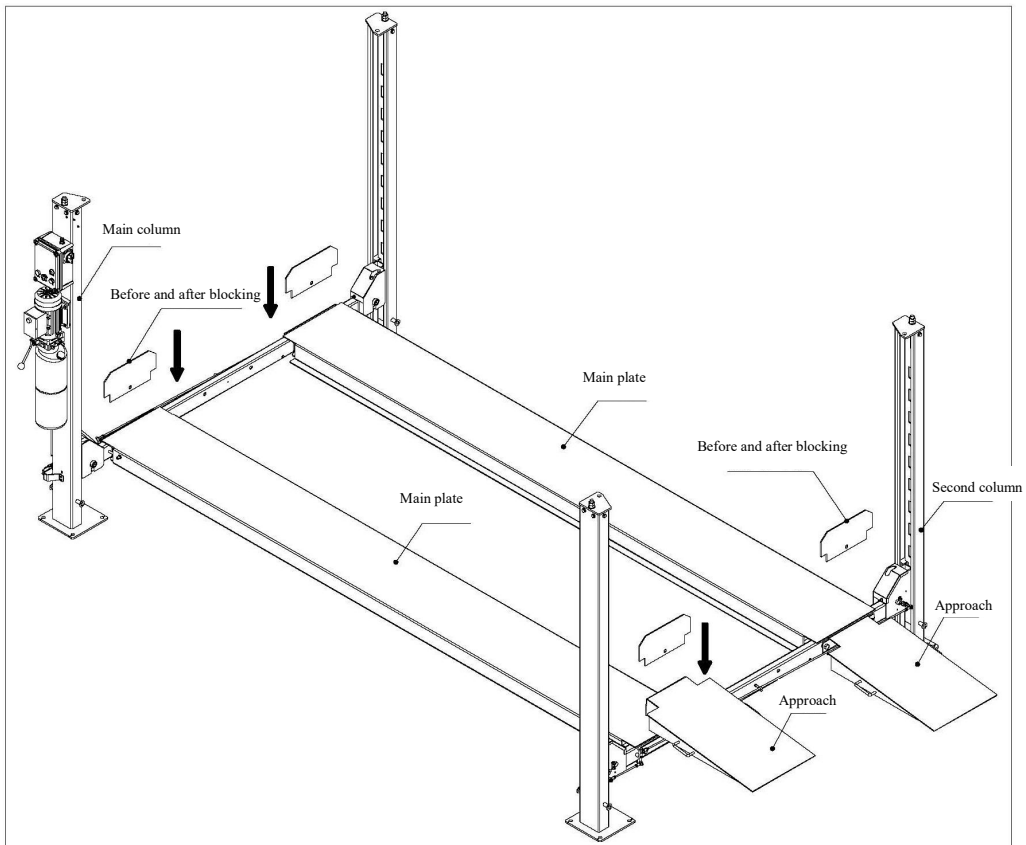

**Step 15: Fill up with hydraulic fluid**

Note: when the actual temperature is above 18 degrees, it is recommended to use No. 46 anti-wear hydraulic fluid. When the temperature is lower than 18 degrees, 32 anti-wear hydraulic oil is recommended. The viscosity of the hydraulic oil largely determines the lifting speed of the lifter.

The tank has a capacity of 10L, usually only a capacity of 80%.

**Step 16: Connect the power supply, test run;**

- 1.Connect the power source according to the power instructions on the machine nameplate.
- 2.Check the mechanical latch state insurance.
- 3.No vehicles shall be placed during the trial run.
- 4.Make sure all the connections are in good condition

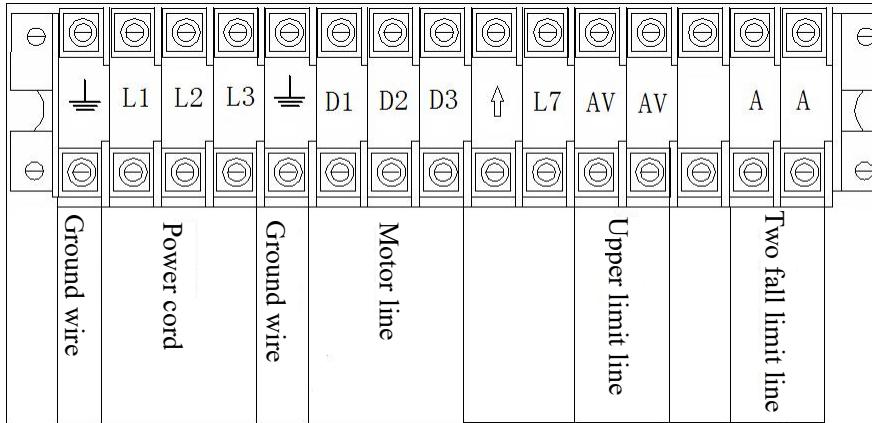

**Step 17: Adjust the level of the lifting machine at four points**

Please do not place any vehicle in adjustment time

**A: Leveling of the whole machine**

Open the power switch on the control box, release the emergency stop switch, press the up button, such as wire rope tension after all, measure the 2 end of the beam to the main side column base plate distance is equal, if not equal, adjust the top of the column nut until the wire rope 2 beam four end end plate distance line.

**B: Leveling of insurance**

Hold the unloading handle of the power unit, lift down, until the fall to insurance work state, the wire rope is slack at the moment, measuring the 2 end of the beam to the main side column base plate distance is equal, if not equal, adjust the top of the column insurance nut until the 2 beam four end the bottom plate distance line.

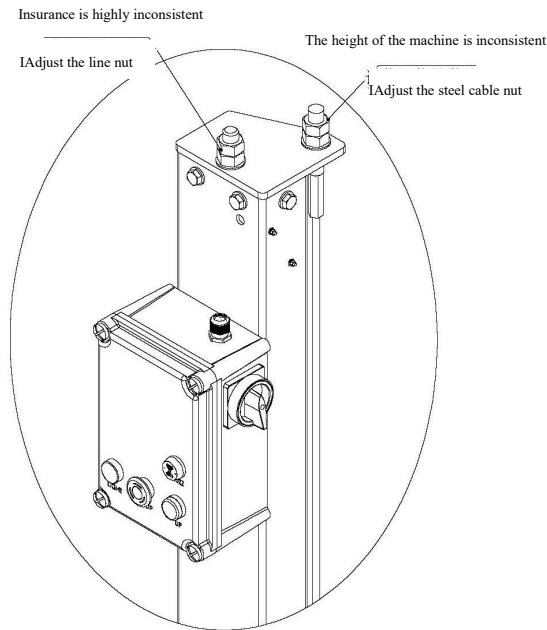

**Step18 : Method for fixing four column parking garage**

**Installation of expansion bolts in accordance with the foundation diagram, before installation, you need to determine the relative position of the four pillars, the error must not exceed 5mm, and draw the outline of the motherboard with chalk, the specific steps are as follows:**

1. Use electric hammer drill to swell the bolt mounting hole, energize vertically, do not allow the drill to tilt.
2. Drill through the hole and sweep away the dust, Make sure that the bottom plate is aligned with the line to be drawn during drilling.
3. If the plate requires gaskets to ensure the level, plug the appropriate quantity of the gasket so that the expansion bolt is tightened and the column and the ground are vertical. Plug in the gasket and start tightening the expansion bolts.
4. Follow the chalk line to position the main column. Install the secondary column in accordance with steps 1,2,3.

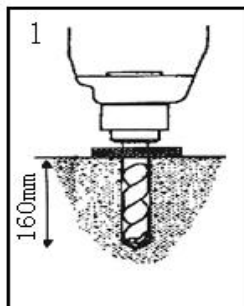

Drill hole

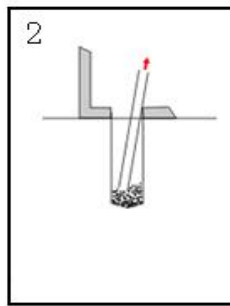

Dust removal

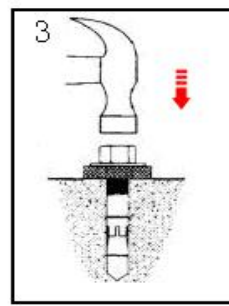

knock expansion pin

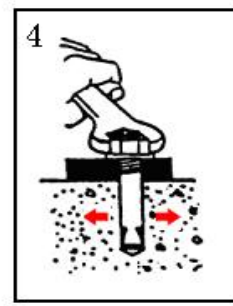

Wrench tightening

**Step 19: Use of mobile kits,**

# Car lift installation, operation and maintenance manual

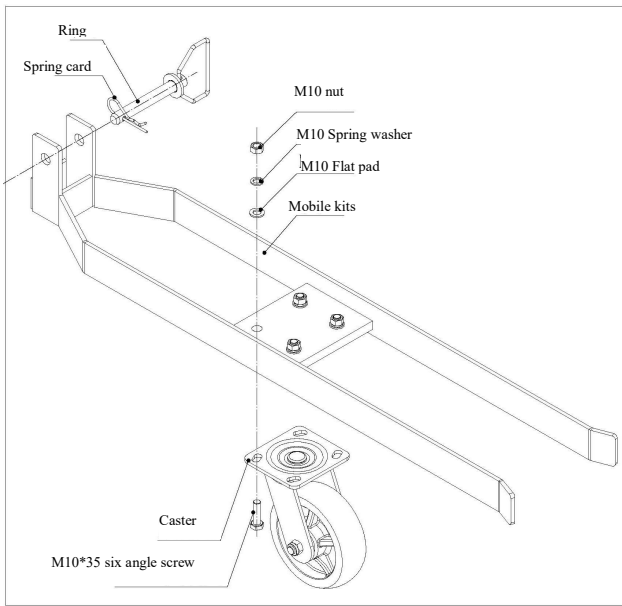

Mobile group components

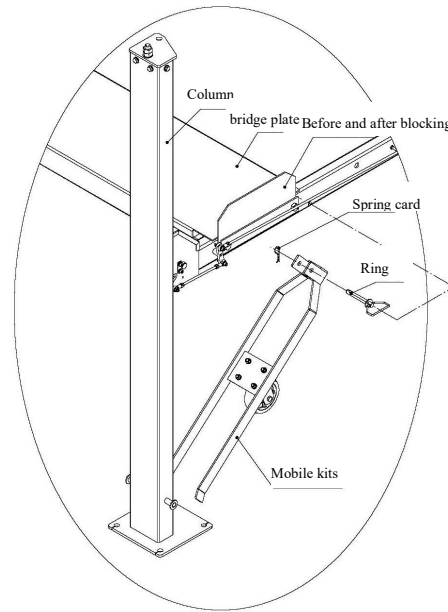

Installation of mobile unit on the whole machine

The function of the mobile kits is as follows:

A: The only function of the mobile kits is to move the whole machine.

B: When lifting the vehicle, the moving group assembly must be removed, and the whole machine is secured with expansion screws.

## Step 20: Install the oil pan and tools.

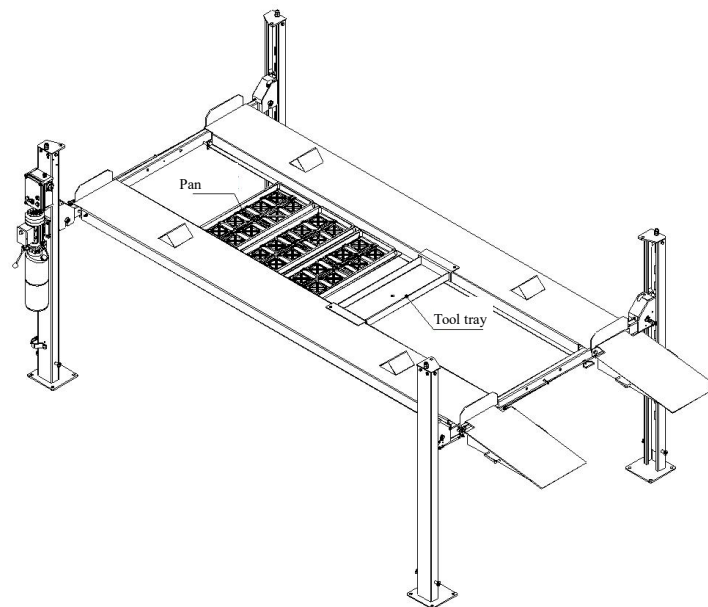

### Attention:

1. The above steps are all the installation steps of the four column parking,

2. committed to continuously improve product quality, update technical specifications, subject to change without notice.

### 3.4 Check the items after installation

- |   |                                                          |   |                                               |   |                                     |
|---|----------------------------------------------------------|---|-----------------------------------------------|---|-------------------------------------|
| 1 | The upright post is perpendicular to the ground          | 2 | Tubing connections are in place               | 3 | The wire rope is connected in place |
| 4 | The main and auxiliary lifting bridge installed in place | 5 | The electrical connection is correct          | 6 | Fastening of other parts            |
|   |                                                          | 7 | The part that needs lubrication is lubricated |   |                                     |

## OPERATION

### 4.1 Operating instructions

- 4.1.1 Check all connections and hose connections, the machine can be used only when there is no oil leakage.
- 4.1.2 The lift, if its safety device malfunctions, shall not be used.
- 4.1.3 The machine shall not lift or lower an automobile if the center of gravity of automobile is not within the supporting range of the supporting device. Otherwise, the manufacturer will not bear any responsibility for the consequence resulted from the operation above mentioned.
- 4.1.4 The staff or operators shall be in a safe position when the machine lift or lower.
- 4.1.5 When lifting arms are in high position, The power must be switched off to avoid misoperation by non operating personnel.
- 4.1.6 When working under the car, you must press down handle to make sure the safety lock is in occlusion. In the process of lifting and descending, people mustn't be under the vehicle.

### 4.2 Control box panel description: (Control box is optional)

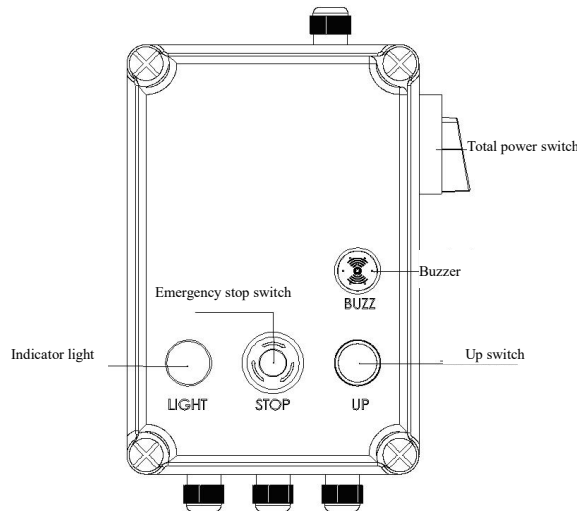

### 4.3 Operation flow chart (With the control box, with two times down the operation process)

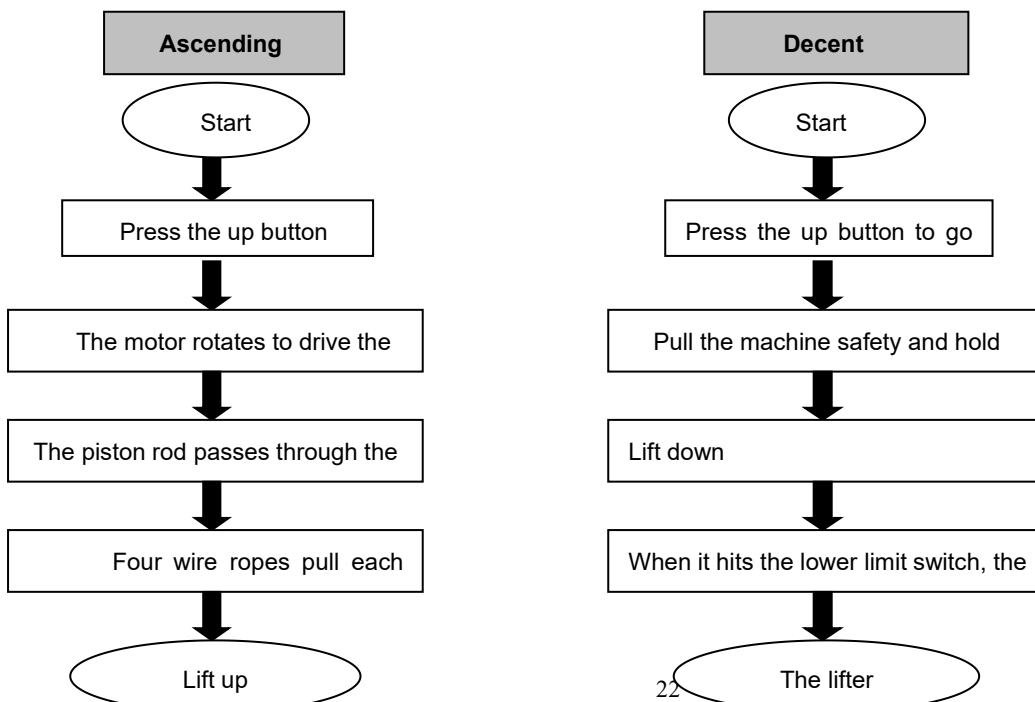

#### 4. 4 Instructions for use

##### **Raising the lift**

1. Turn on the power.
2. Place the vehicle in the middle of the platform, otherwise rollover risk may occur.
3. Press the up button to raise the lift to the height you need. Release the lift button and the lift stops immediately.
4. When rises to the required height, check the car is safe, then press down power unit on the unloading valve handle, let the safety lock in place, turn off the power, can work under the carriage.

##### **Lowering the lift**

1. Check whether there is any obstacle below the lifter.
2. Turn on the power.
3. Push the rise bottom to let the safety lock out of joint.
4. Hold down the safety handle and hold down the drop unload handle on the power unit, then the lifter falls.
5. When the machine hits the lower limit switch, the buzzer alarms and the lifter continues to fall until it reaches its lowest position. (this function is optional)
6. Drive away the vehicle.

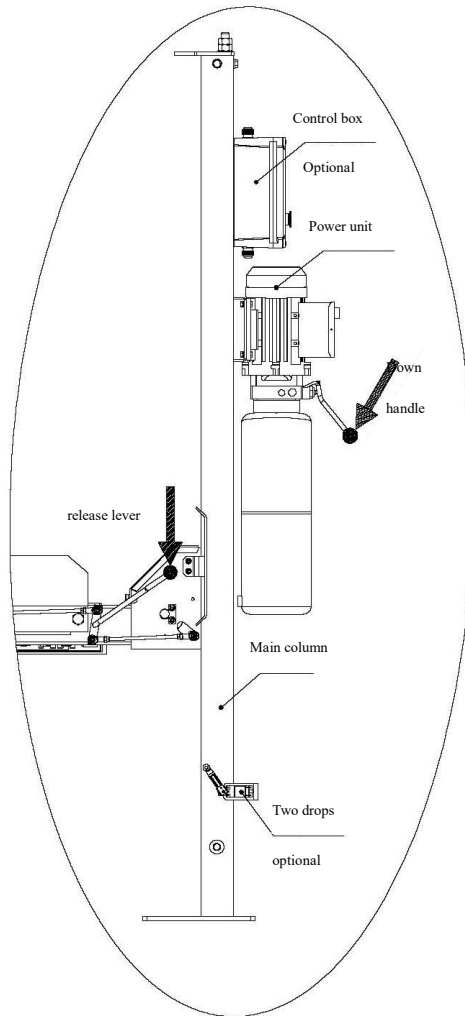

### TROUBLE SHOOTING

**Caution:** If you are unable to resolve the problem, please contact the manufacturer for assistance. We will be the first to help you solve the problem, provide relevant failure messages and picture of failure, so that manufacturers can troubleshoot you at the fastest speed.

Phenomenon	Reason	Method
Lift makes excessive noise	Friction mark inside column	Add some lubricating oil
	Obstacle inside column	Clear the inner obstacles
Motor does not run	Motor broken line burn out	Replace motor
	Bad wire contact	Check and connect the line
	The limit switch is off line, bad operation, damage	Connect the line. Adjust or change the limit switch.
Motor runs but will not rise	Motor reversal	Corrective wiring method
	Overflow valve loose or blocked	Adjust or clean overflow valve
	Gear pump damage	Replace gear pump
	Hydraulic oil shortage	Supply hydraulic oil
	Oil suction pipe loose and fall off	Tighten the suction pipe

## Car lift installation, operation and maintenance manual

	Cushion valve is loose or blocked	Tighten or clean the cushion valve
Lift go down itself after lifting up	Cylinder seal is bad	Replace seals
	Check the oil hose for leaks	Change the oil hose
	One way valve is not sealed properly	Decompose, clean, remove, or replace
	Overflow valve is not good	Decompose, clean, remove, or replace
	Manual unloading valve or electromagnetic unloading valve	Decompose, clean, remove, or replace
	Steel cable is loose	Check whether the steel cable is flat
Rise slowly	Oil filter is blocked	Clean, remove, or replace
	Oil pressure is mixed air	Supplemental hydraulic fluid
	Overflow valve adjustment is not in place	Adjustment
	Hydraulic oil becomes hot (45° above)	Replace hydraulic oil
	Cylinder seal abrasion	Replace seals
	The cylinder lubrication is poor	Replace the lubricant
Slow down	The downward throttle is stuck and has obstructions	Clean, remove, or replace
	The hydraulic oil is dirty	Replace hydraulic oil
	Explosion-proof parachute valve has obstruction	Replace Explosion-proof parachute valve
	Hydraulic hose has an obstruction	Hydraulic hose has an obstruction
Steel cable is not smooth	No grease lubrication during installation	Replace steel cable

## MAINTENANCE

The several pieces of maintenance operations to be carried out are described below. A low operating cost and a long life of the machine are from routine observation of there operations.

The routine maintenance of the following recommendations can be referred to the use environment and times of the lifter.

**Components require lubrication as follow :**

- A: The steel cable needs lubrication
- B: The slider inside the column needs lubrication
- C: All cable axles need lubrication
- D: The main insurance needs lubrication
- E: Cable breakage requires lubrication

### 6.1 Daily pre-operation check

The user should perform daily check. Daily check of safety latch system is very important the discovery of device failure before needed could save you from expensive property damage, lost production time, serious personal injury, even death.

▲At the time of the operation, according to the sound judgment occlusion safety lock.

- ▲ Check hydraulic connections, and hoses for leakage.
- ▲ Check chain connections, cable connections, wiring and switch for damage.
- ▲ Check the tightness of the expansion bolt. (Inspection items used when fixing methods)

**6.2 Weekly maintenance**

- ▲ Check the flexibility of the action components.
- ▲ Check the safety device as previously described.
- ▲ Check hydraulic fluid level as follow: let the trolleys go up completely and in case they do not reach maximum height, add oil.
- ▲ Check the tightness of the expansion bolt. (Inspection items used when fixing methods)

**6.3 Monthly maintenance**

- ▲ Check the tightening of screws.
- ▲ Check the hydraulic system seal and tighten the loose unions, if necessary.
- ▲ Check the greasing and wear condition of pins, rollers, bushes, of trolley structure as well as arms and relevant extensions, if necessary, replace the damaged parts by original spare parts.
- ▲ Check the lubrication and wear of the steel cable.

**6.4 Yearly maintenance**

- ▲ Empty the tank and check the conditions of the hydraulic fluid.
- ▲ Clear the oil filter.

**Caution: If the above maintenance operations are carried out, there will be an advantage for the user, who will find the equipment in perfect condition each time he restarts work.**

**ENCLOSURE**

**Enclosure 1: Packing list**

No.	Name	Source	No.	Remark
1	Main bridge plate	Assembly parts	1	
2	Second bridge plate	Assembly parts	1	
3	Main column	Assembly parts	1	
4	Secondary column	Assembly parts	2	
5	Secondary column A	Assembly parts	1	
6	Beam assembly	assembling	2	
7	Approach bridge welding	welding	2	
8	Pan	Outsourcing	3	
9	Tool plate welding	welding	1	
10	Power unit	Outsourcing	1	240V/50Hz/1PH
11	Mobile group components	assembling	4	

## Car lift installation, operation and maintenance manual

12	Before and after blocking	Self-control	4	
13	Dashboard bezel	welding	4	
14	Tyre retaining bracket	welding	4	
15	Insurance institution		1 set	
16	Parts box		1	

### Insurance institutions

No.	Name	Source	No.	Remark
1	Main handle weld	welding	1	Galvanized
2	Auxiliary safety rod welding	welding	1	Galvanized
3	M8*40 six angle screw	Outsourcing	4	Galvanized
4	M8 flat pad	Outsourcing	4	Galvanized
5	M8 lock nut	Outsourcing	4	Galvanized
6	Main and secondary safety handle connecting rod	Outsourcing	1	Galvanized
7	Handle isolating sleeve	Outsourcing	2	Galvanized
8	Connecting rod threaded rod	Outsourcing	2	Galvanized
9	M12 nut	Outsourcing	4	Galvanized
10	Long rod	Outsourcing	2	Galvanized
11	M8 nut	Outsourcing	4	Galvanized
12	Rubber ball	Outsourcing	1	

### Spare parts list

No.	Name	Source	No.	Remark
1	M16*120 expansion bolt	Outsourcing	16	Galvanized
2	M8*25 six angle screw	Outsourcing	4	Galvanized
3	M8 flat pad	Outsourcing	4	Galvanized
4	M8 cushion	Outsourcing	4	Galvanized
5	M8 nut	Outsourcing	4	Galvanized
6	Main safety link	Outsourcing	4	Galvanized
7	M10 lock nut	Outsourcing	4	Galvanized
8	Long tie rod retaining ring	Outsourcing	2	Galvanized
9	M8 nut	Outsourcing	2	Galvanized
10	M18*110 outer six corner screw	Outsourcing	8	Galvanized
11	M18 flat pad	Outsourcing	8	Galvanized
12	M18 cushion	Outsourcing	8	Galvanized
13	M18 nut	Outsourcing	8	Galvanized
14	Tie rod	Outsourcing	2	Galvanized
15	M8 outer six angle nut	Outsourcing	4	Galvanized
16	Purchase universal Earrings	Outsourcing	8	Galvanized
17	Ring	Outsourcing	4	Galvanized

**Car lift installation, operation and maintenance manual**

18	Spring card	Outsourcing	4	Galvanized
19	Main oil pipe 1800	Outsourcing	1	
20	Three way ball valve joint	Outsourcing	1	When the pump station is not available, the parts box must be matched
21	M14 combination washer	Outsourcing	1	
22	Instructions		1	

**Optional**

1	Control box	Outsourcing	1	240V/50Hz/1PH (control box)
2	M5*12 cross head screw	Outsourcing	2	
3	Forming switch	Outsourcing	1	Travel switch with line 2*0.75 square meters 1 meters (upper limit switch)
4	M4*16 cross head screw	Outsourcing	4	
5	M4 flat pad	Outsourcing	4	
6	M4 cushion	Outsourcing	4	
7	M4 nut	Outsourcing	4	
8	Two time limit switch fixed plate	Self-control	1	
9	Two times down bezel welding	Self-control	1	
10	Limit switch assembly	Outsourcing	1	Limit switch with line 2*0.75 square meters 1.8 meters (two descent)
11	M5*12 cross head screw	Outsourcing	4	
12	M8*16 six angle screw	Outsourcing	2	
13	M8 cushion	Outsourcing	2	
14	M8 flat pad	Outsourcing	2	

**Attention:**

**The two drop must be used in conjunction with the control box**

**Enclosure 2: dimensions drawing**

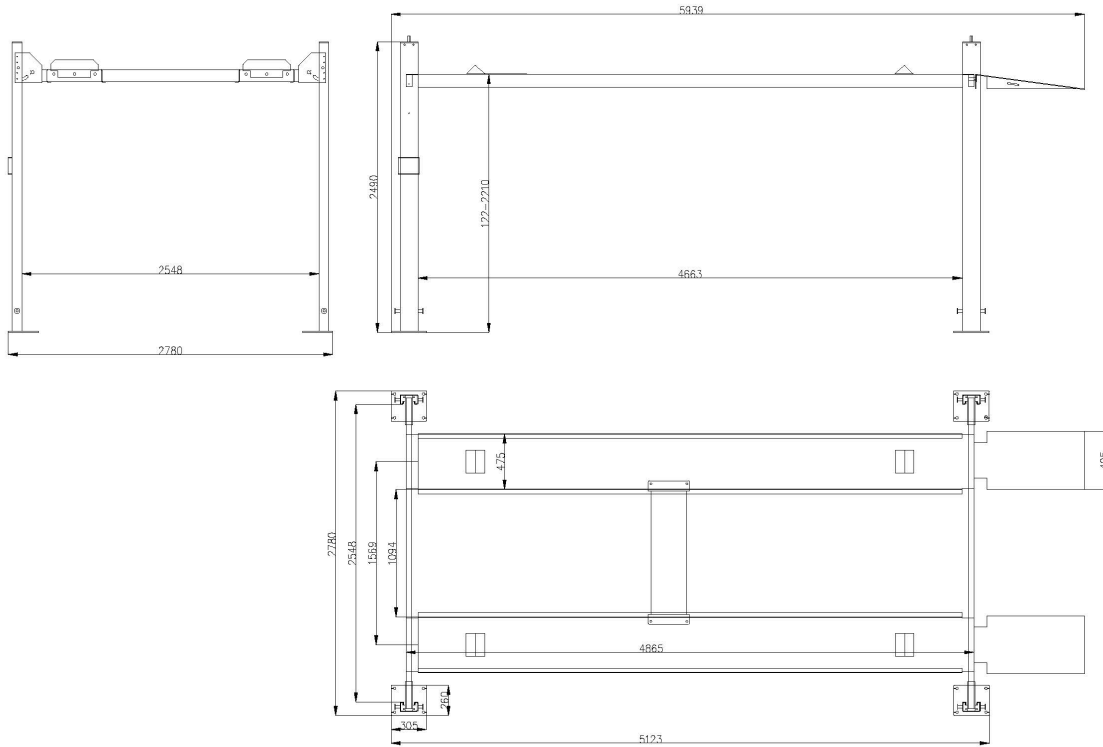

**Enclosure 3: Foundation installation drawing**

The foundation diagram of the lifting machine in fixed use is as follows

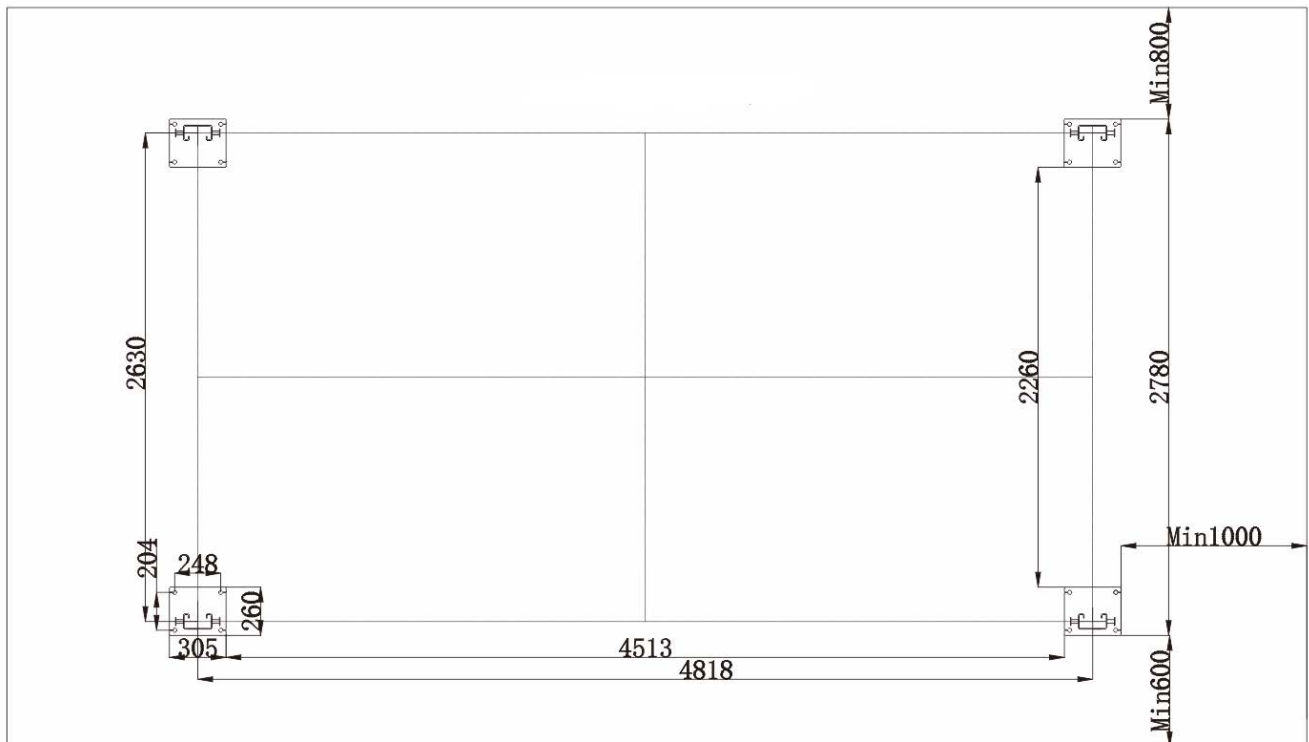

**Enclosure 4: Hydraulic principle diagram**

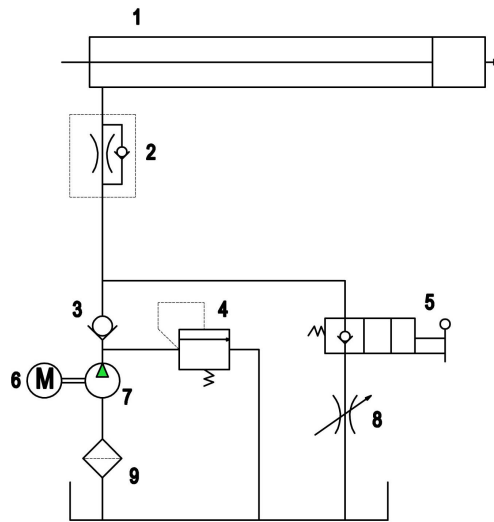

1. cylinder, 2. throttle valve, 3. check valve, 4. relief valve, 5. manual unloading valve, 6. motor, 7. gear pump, 8. flow control valve, 9. filter screen

**Enclosure 5: Schematic diagram of electrical equipment**

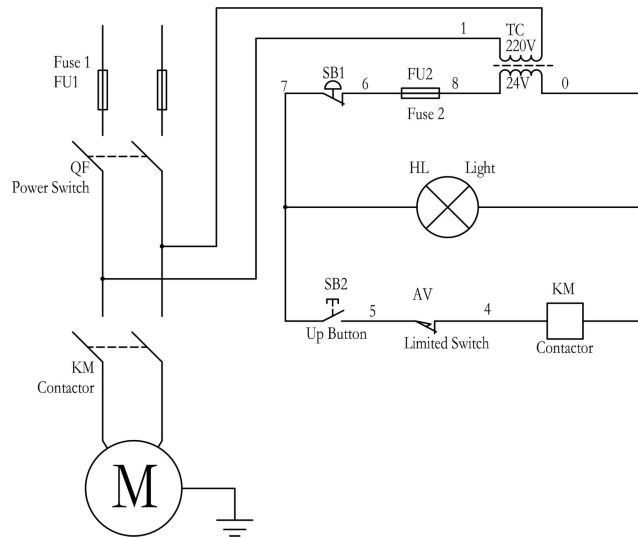

Circuit diagram A (without two drops)

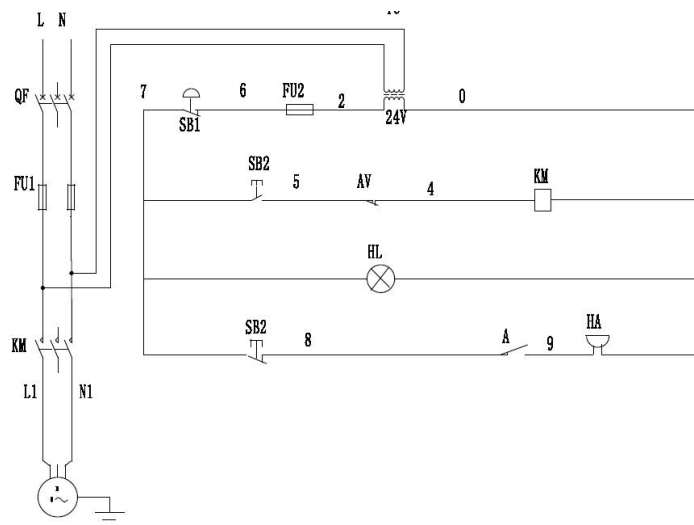

Circuit diagram B (with two drops)