

# 71.3DWA

## FOUR-WHEEL ALIGNER — Visual 3D INSTRUCTION & MAINTENANCE MANUAL

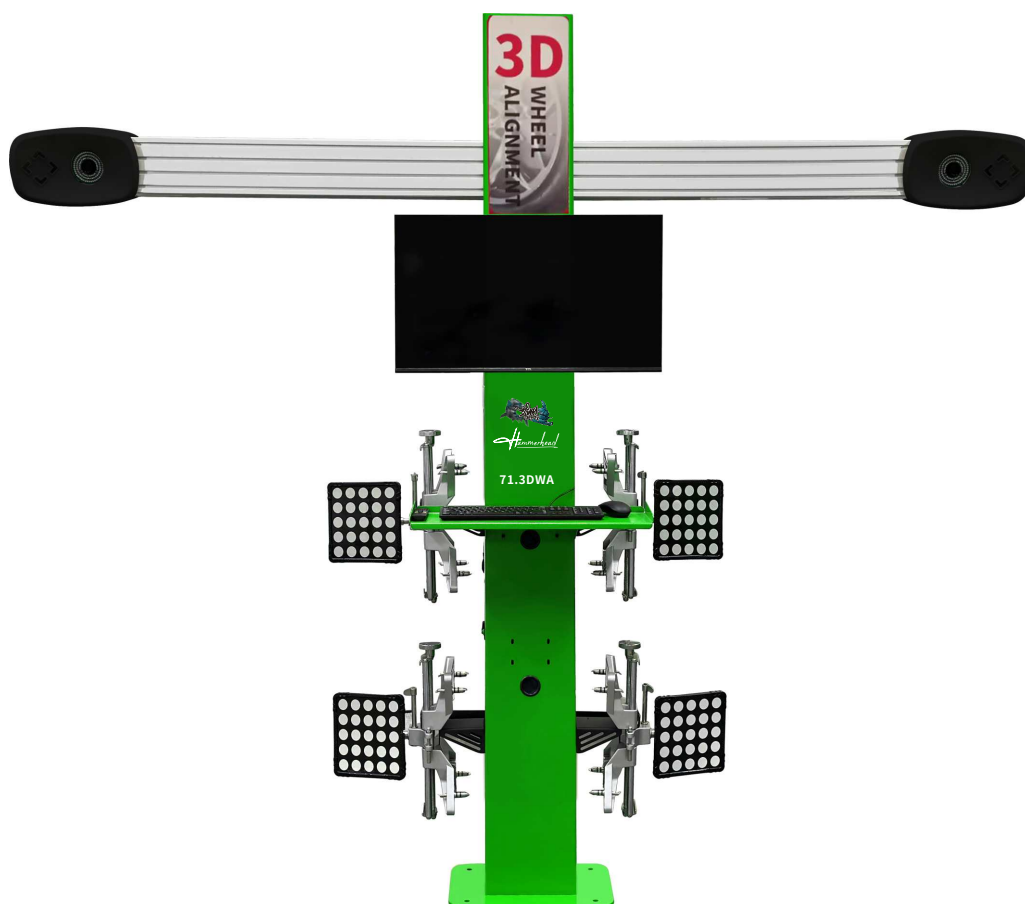

**Jimy Industrial Pty Ltd**  
5 Cord St  
Dudley Park, 5008  
Ph: (08) 8269 9700  
W: [www.jimytools.com.au](http://www.jimytools.com.au)  
E: [sales@jimytools.com.au](mailto:sales@jimytools.com.au)

# Catalogs

<b>CHAPTER I. PRODUCT INTRODUCTION &amp; TECHNICAL SPECIFICATION .....</b>	<b>1</b>
1. PRODUCT INTRODUCTION .....	1
2. TECHNICAL SPECIFICATION .....	1
3. GENERAL DIAGRAM OF FOUR-WHEEL ALIGNMENT .....	2
4. FOUR-WHEEL ALIGNER INSTALLATION DIAGRAM .....	2
5. POWER REQUIREMENT: .....	3
6. ENVIRONMENTAL REQUIREMENT: .....	4
7. GENERAL SAFETY NOTE: .....	4
<b>CHAPTER II. VEHICLE PREPARATION, SELECTION AND USE OF SUPPORT TOOL .....</b>	<b>5</b>
1. PLACEMENT OF VEHICLE: .....	5
2. USE OF REAR WHEEL WEDGE .....	5
3. MOUNTING OF CLAMP .....	5
<b>CHAPTER III. FOUR-WHEEL ALIGNER OPERATION PROCEDURE .....</b>	<b>7</b>
1. PREPARATION AND LIMITATION PRIOR TO THE FOUR-WHEEL ALIGNMENT OPERATION: .....	7
2. INITIAL INTERFACE .....	8
3. SELECT MODEL .....	9
4. MEASUREMENT PREPARATION .....	10
5. STEERING WHEEL CENTERED AND LOCKED .....	10
6. DYNAMIC MEASUREMENT-TOE & CAMBER .....	11
7. KINGPIN INCLINATION & CASTER MEASUREMENT .....	12
8. ADDITIONAL FUNCTION-WHEELBASE AND WHEEL WIDTH MEASUREMENT .....	13
9. ANALYSIS AND ADJUSTMENT .....	13
10. PRINT RESULT .....	15
<b>CHAPTER IV. ADDITIONAL SOFTWARE FUNCTIONS .....</b>	<b>16</b>
1. CHASSIS WHEELBASE AND WHEELBASE SIZE DETECTION .....	16
2. TIRE ACTUAL SIZE INSPECTION .....	16
3. ENGINE BRACKET ADJUSTMENT FUNCTION .....	17
<b>CHAPTER V SOFTWARE SETTING FUNCTION .....</b>	<b>17</b>
<b>CHAPTER VI DATABASE MAINTENANCE .....</b>	<b>18</b>
<b>CHAPTER VII. SECURITY INFORMATION .....</b>	<b>19</b>
<b>CHAPTER VIII. EQUIPMENT PACKAGE .....</b>	<b>20</b>
<b>CHAPTER IX. EQUIPMENT HANDLING .....</b>	<b>21</b>
<b>CHAPTER X. ENVIRONMENT FOR STORAGE &amp; USE OF EQUIPMENT .....</b>	<b>21</b>
<b>CHAPTER XI FOUR-WHEEL ALIGNER MAINTENANCE PRECAUTION .....</b>	<b>22</b>
<b>CHAPTER XII COMMON FAILURE AND SOLUTION .....</b>	<b>22</b>

# Chapter I. Product Introduction & Technical Specification

## 1. Product Introduction

The automobile wheel aligner is used to detect the wheel alignment parameters of the automobile and compare them with the standard parameters designed by the original manufacturer, to guide the user to adjust the wheel alignment parameters accordingly, to make them conform to the requirements of the original design, to achieve the ideal automobile driving performance. This is a precision measuring and adjusting guideline instrument to make the vehicle handle lightly, drive straight, and reduce the problem of tire bias wear.

Main features of this product:

- Using advanced 3D image acquisition technology and software algorithms, it is fast and accurate, durable and easy to use;
- By pushing the car front and rear, the camera can immediately display the toe value of the front wheels of the car, the camber angle of the front wheels, the Setback angle of the front wheels, the toe value of the rear wheels, the camber angle of the rear wheels and the thrust angle after the camera has taken the photographs of the 4 target targets;
- By turning the steering wheel, the Kingpin inclination angle and caster angle can be measured;
- Friendly human-computer interaction software interface, operation step-by-step guide image simple, easy to get started;
- It can quickly retrieve wheel alignment data of nearly 40,000 kinds of cars in the world, and provide a user library for users to input wheel alignment data of cars by themselves, or download new data of car alignment from the Internet;
- Simple and reliable clamping of clamps and targets;
- Equipped with a standard printer to print out the measurement results;
- There is a function for storing user information and a history library of the car's measurement data, which can be printed out.

## 2. Technical Specification

Front target target plate to camera distance	1750mm-2550mm
Front target plate to camera distance - optimal	1900mm
Longest wheelbase of a vehicle	<3750mm, $\pm 2.5$ mm
Track width	<1750mm, $\pm 2.5$ mm
Wheel diameter	12"-24"
Camera beam height	968mm-2188mm

### 3. General Diagram of Four-wheel Alignment

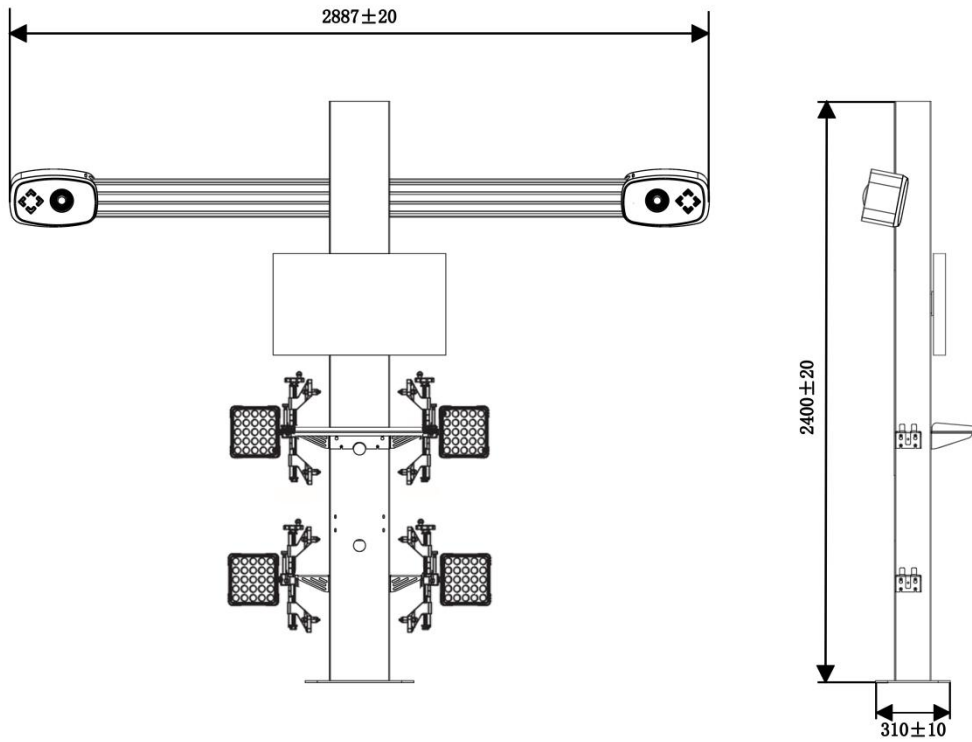

### 4. Four-wheel aligner installation diagram

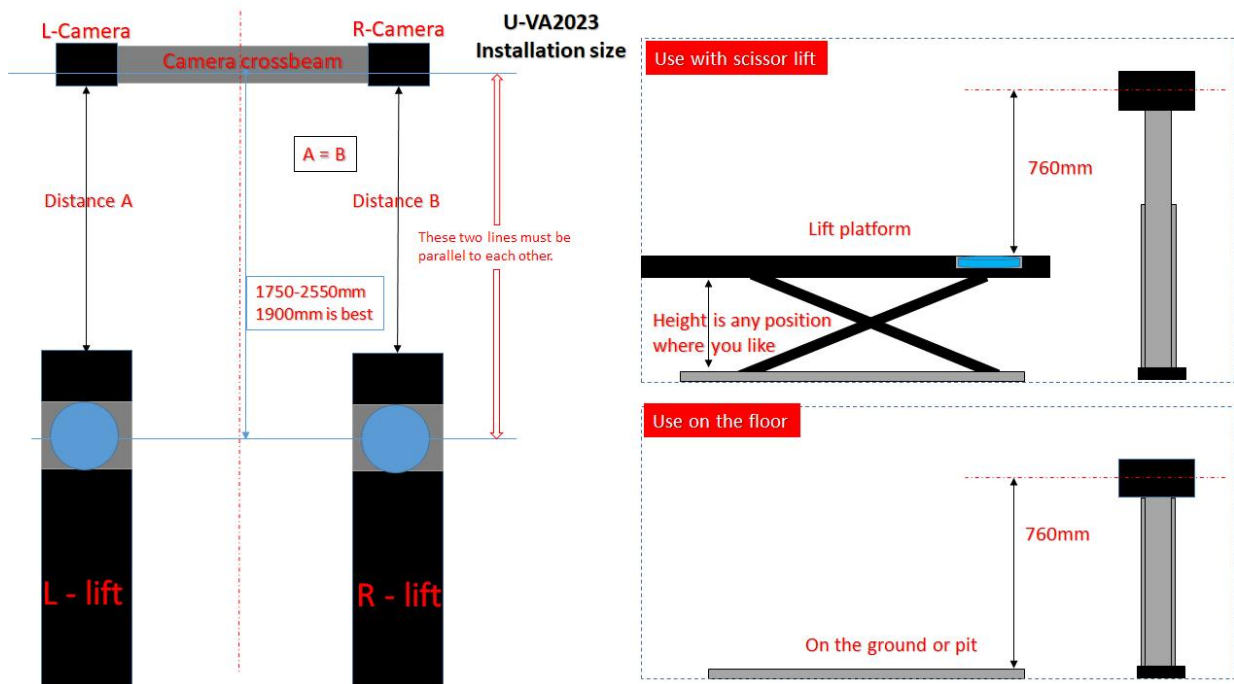

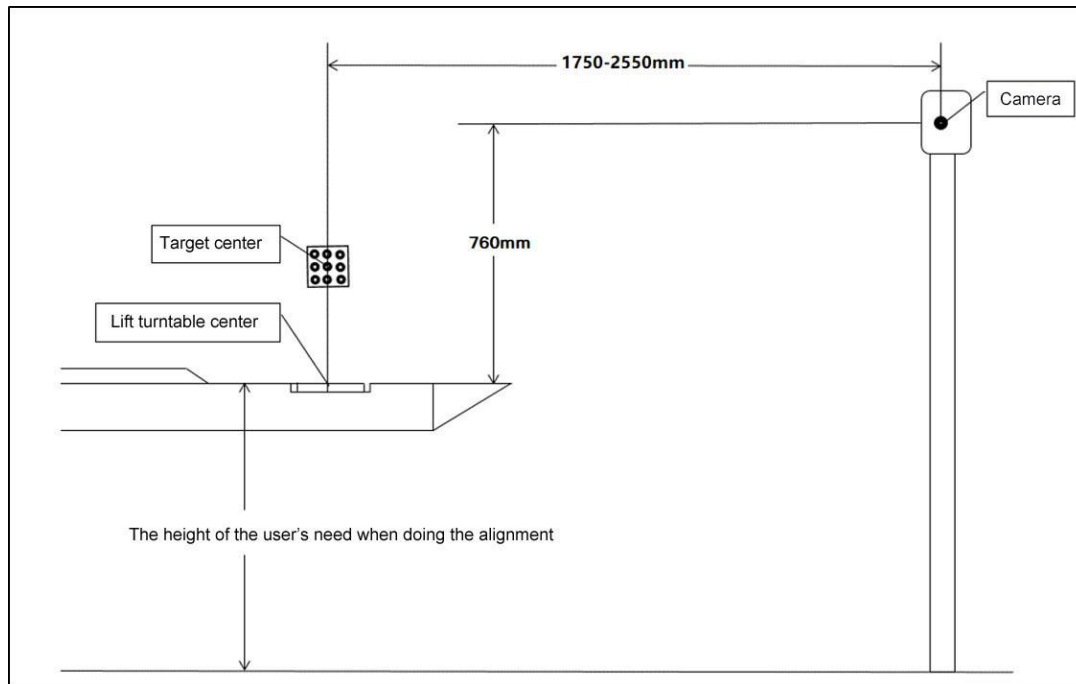

The columns are first spliced together by laying them flat on the ground, then the beams are fitted into the fixing holes in the upper columns to lock the screws. Then use a suitable lifting method to erect the equipment to the installation position and drive the ground screws.

Foundation requirements:

Concrete with a drying period of 20 days; strength  $\geq$  C30;

Concrete surface area  $\geq$  600x600 square millimeter;

Concrete thickness > 150mm;

The levelness of the concrete surface should be  $\leq$  2mm.

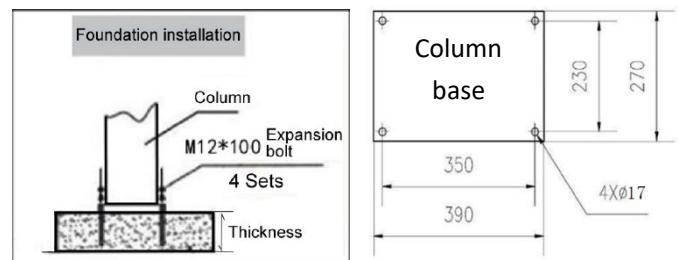

**Precautions for four-wheel aligner:**

**Carefully read and keep all the information provided randomly, and fully understand the use of the machine and precautions.**

**The computerized four-wheel aligner is a precision instrument and requires special management and use.**

**The computer of the four-wheel aligner is specialized in serving the equipment, and is not allowed to be loaded with other software or hardware; it is not allowed to delete or change the various applications in the computer at will; non-equipment maintenance personnel should not mess with the computer.**

## 5. Power Requirement:

This machine uses AC single phase AC200V~AC240V,50HZ power supply.

It is best to have an independent power supply with ground wire, do not use the same power supply with the equipment that interferes greatly, too low or too high a voltage may cause the machine to be unstable or even burned, it is best to use a voltage regulator and UPS.

Be sure to use a three-pronged power plug and socket with grounding protection to ensure personal safety and equipment stability.

After shutting down the computer in Windows, please turn off the power switch on the column together to avoid the damage of the power grid spike on your equipment.

Special attention must be paid to the power supply equipment connected to the machine must comply with national electrical standards, such as do not overload, the line must be safe, etc. Otherwise cause damage to the machine, such as the machine must not be overloaded. Otherwise, the company will not be responsible for any damage caused to the

machine, such as burnt, etc. The company will not be responsible for the warranty of such problems.

In the event that you have not cut off the power supply must not be the machine's various wires for unplugging, plugging operation.

## 6. Environmental Requirement:

This machine is suitable for working between 0 and 40°C. If your working environment temperature is higher or lower than this temperature, the machine may not work properly. Please take measures to ensure the working environment temperature;

Your computer should be used with care to dissipate heat;

Do not place your computer near a heat source or in direct sunlight;

Keep the area around the machine well ventilated;

Do not have other objects blocking the heat dissipation holes of the host computer, monitor and other components;

The working place of the four-wheel aligner should be moisture-proof and anticorrosive; working in a humid environment will adversely affect the use of the computer;

For cleaning, please use a non-woven cloth to wipe gently or use a neutral cleaner with warm combination;

Once splashed water or other liquids on the computer, the power supply should be cut off immediately;

Do a good job of dust treatment to ensure that the equipment is clean, in order to extend the service life of the entire machine;

Some parts of the four-wheel aligner, such as the monitor, are sensitive to magnets, do not place the computer and disks close to magnets.

**Precautions for the use of the target: In order to ensure the safe and reliable work of the machine and high precision measurement, please note the following points:**

Target should avoid strong light or sunlight interference during use, otherwise it can't work normally.

After use, it should be placed in a ventilated, dry and safe place.

The surface of target should be cleaned and wiped with soft cloth regularly.

The target should not be shaken, bumped or slipped to avoid damage to the sensing element.

Do not disassemble and change the original structure.

The clamp must be firmly mounted on the rim and protected from accidents by a matching rubber band.

**Precautions for installing the column:**

The level of the floor of the base plate of the column is <2mm;

Floor cement thickness >150mm, the minimum length and width of the floor of this thickness 600x600mm;

Concrete strength C30 and above.

## 7. General Safety Note:

Read this manual before operating or servicing the four-wheel aligner;

Be sure the column and cabinet are mounted and placed on a level, vibration-free flat surface;

Make sure the power supply is consistent with the requirements of the machine;

The instrument must be connected to the grounding wire and grounded well when used, and the ground wire is struck down to the ground for more than 1.5 meters;

Instrument maintenance must be operated by the Company's approved professionals, the beam assembly must be sent back to the Company's maintenance center;

It is recommended to turn off the equipment when not in use to prolong the life.

## Chapter II. Vehicle Preparation, Selection and Use of Support Tool

### 1. Placement of Vehicle:

The vehicle to be measured to be set upright and then drive on the lift or gutter, so that the vehicle's two front wheels just fall in the middle of the two turntables (Note: the tire centerline falls in the center of the turntable circle of the correct or not will directly affect the accuracy of the measurement of the Kingpin.) Lifter platform on the two front wheel turntable and rear wheel side skid plate in the car before driving up must be inserted pins, when the vehicle is parked, the wheel wedge will be placed in the rear wheel tires in front of the back of the wedge, you can dial off the turntable pins as needed. The steering wheel must be set up in the center position and tightly locked by the fixing frame. and then lift the lifter to the set height and safe locking.

The car to be tested must be in an unloaded state (heavy objects must be unloaded);

Ensure that the tire pressure is consistent and the tires are well balanced, and that the wheels are not deformed;

Ensure that the car's suspension system has not been hit or damaged and that the connecting ball joints are not too loose (i.e. not too badly worn);



### 2. Use of Rear Wheel Wedge

To prevent the vehicle from moving back and forth in a way that could compromise safety and measurements after the measurement is stopped and when the Kingpin is measured, use a rubber block to hold back the rear wheels and remove the rubber pads by pulling out the cornering disk pins.



### 3. Mounting of Clamp

Place one side of the self-aligning clamp to the deepest part of the wheel rim, loosen the self-aligning clamp until its other side can be placed into the wheel rim, and then tighten the knob of the self-aligning clamp without loosening it, so that the self-aligning clamp climbs tightly on the wheel (this clamp must be clamped at the deepest part of the wheel rim, to avoid any measurement error due to the deformation of the outer edge of the wheel rim).



### 3.1 Selection of the clamp

This clamp is designed for four-wheel alignment test and four-jaw special clamp, in addition to do the ordinary models of four-wheel alignment correction, but also can do the ultra-low chassis car four-wheel alignment correction, beautiful appearance and flexible use.

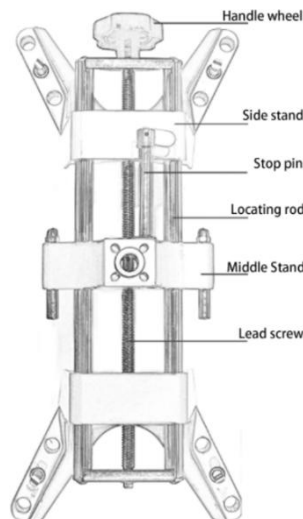

### 3.2 selection of clamp jaws

External support: When the rim has a large curvature, all four jaws must be positioned flush with the rim. (Figure 2)

Outer clamping type: the general edge of the rim of the car, there is no curvature, only a very small rounded end, the four clamping jaws positioning end face must be flush with the edge of the rim. (Figure 3, the common use)

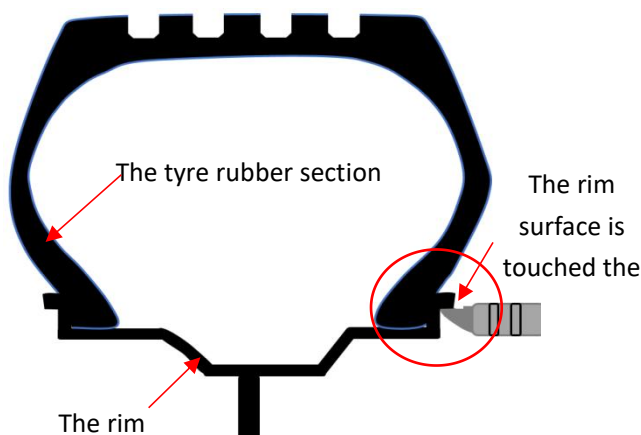

Figure 2

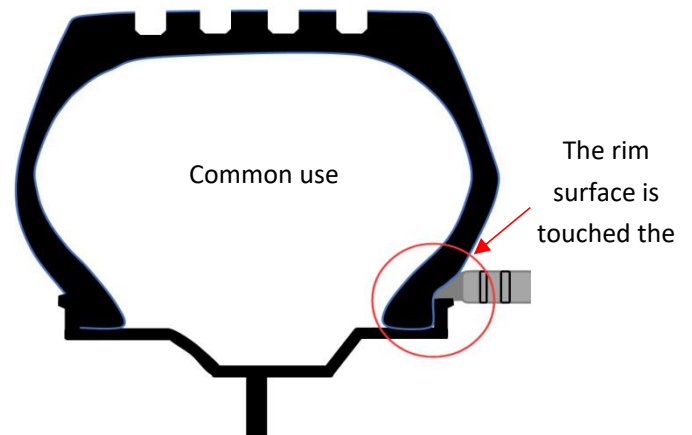
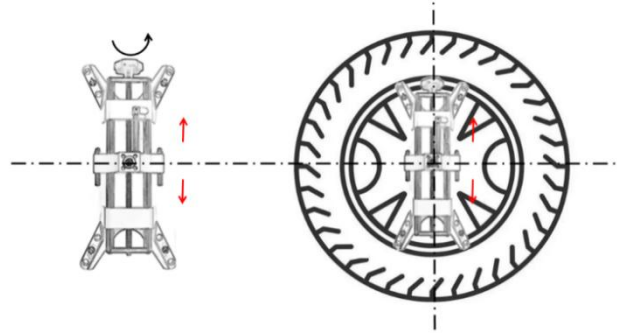

Figure 3

### 3.3 Clamp Installation

This clamp has been factory locked in the center position with a taper pin, so there is no need to adjust the center. Rotate the handwheel to open the jaws to the proper rim diameter. Installation of the clamp requires the handle to be up and perpendicular to the ground; requires the four jaws to be set flush with the edge of the rim; requires the handwheel to be turned again to adjust and lock the clamp in place on the rim, and check that the clamp is securely mounted by shaking it by hand.

**WARNING: To prevent the clamp from slipping, use the matching protective sleeve to secure the clamp to the rim.**



## Chapter III. Four-wheel Aligner Operation Procedure

### 1. Preparation and Limitation Prior to The Four-wheel Alignment Operation:

Before driving the car on the lifter platform, check that the fixing pins of the turntable and the measuring slide plate are in the locked working position.

When the car drives on the lifter platform, adjust the left and right positions of the turntable to ensure that the front and rear directions of the wheels are basically in the center of the turntable to avoid measurement errors.

A After driving the car onto the lifter, block the rear wheels with the rubber stopper (the Wheel wedge) to prevent the car from moving, and then please put the car into neutral, and release the handbrake.

Check the rim size and tire air pressure to see the wear of the tires, the steering system, the state of the suspension system components such as tie rod ball head, damper, etc. If there is any unqualified place, please repair it first, and then carry out four-wheel alignment.

Press down the front and rear of the body with hand force to make the wheels of the car in a free state and adjust the position of the steering wheel.

Install the clamp and target, when installing the clamp, it should be noted that the four jaws of each clamp should be close to the edge of the rim, and each target corresponds to one wheel, meanwhile, use the matching protective sleeve to fix the clamp to make sure the clamp is firmly installed. Tilt the target about 10 degrees forward.

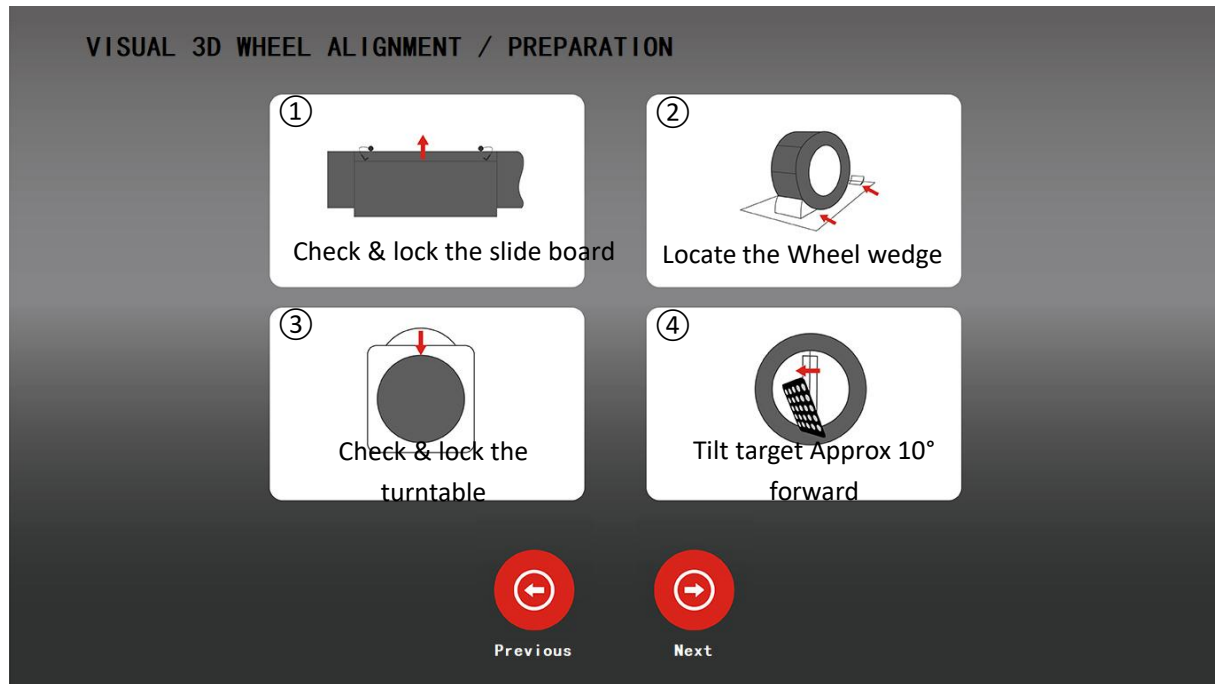

## 2. Initial Interface

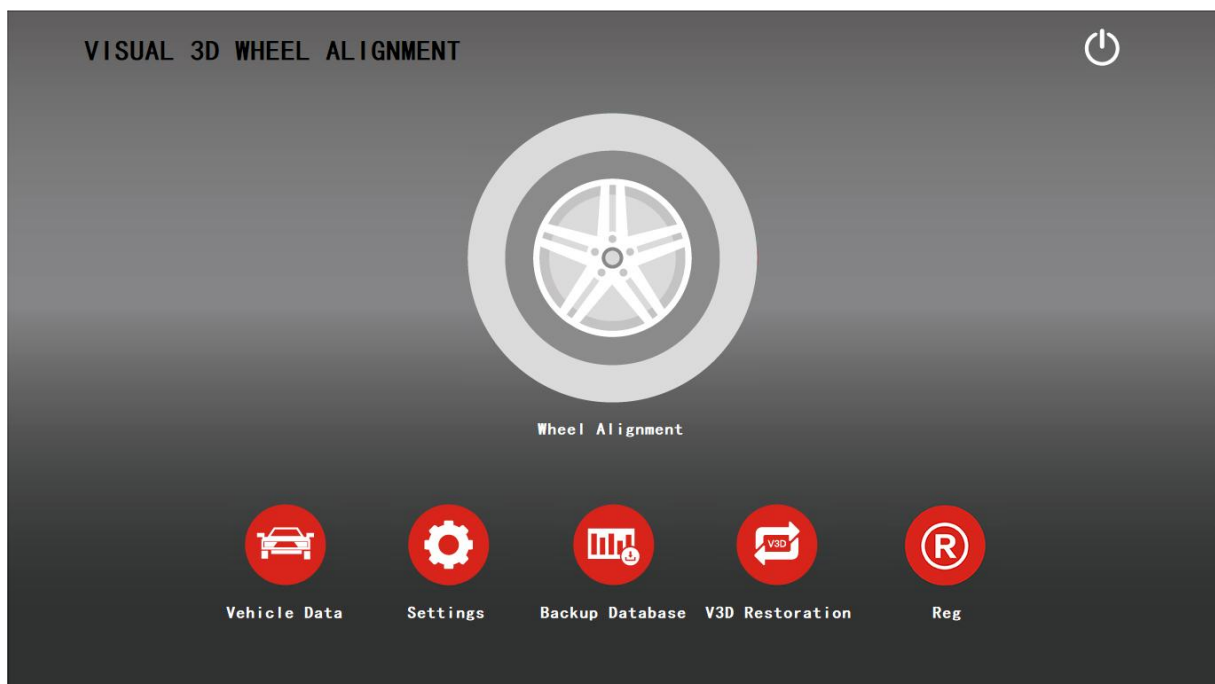

Click "Wheel Alignment" to enter the target detection position interface, make sure that the left and right targets are within the range. As shown in the figure below:

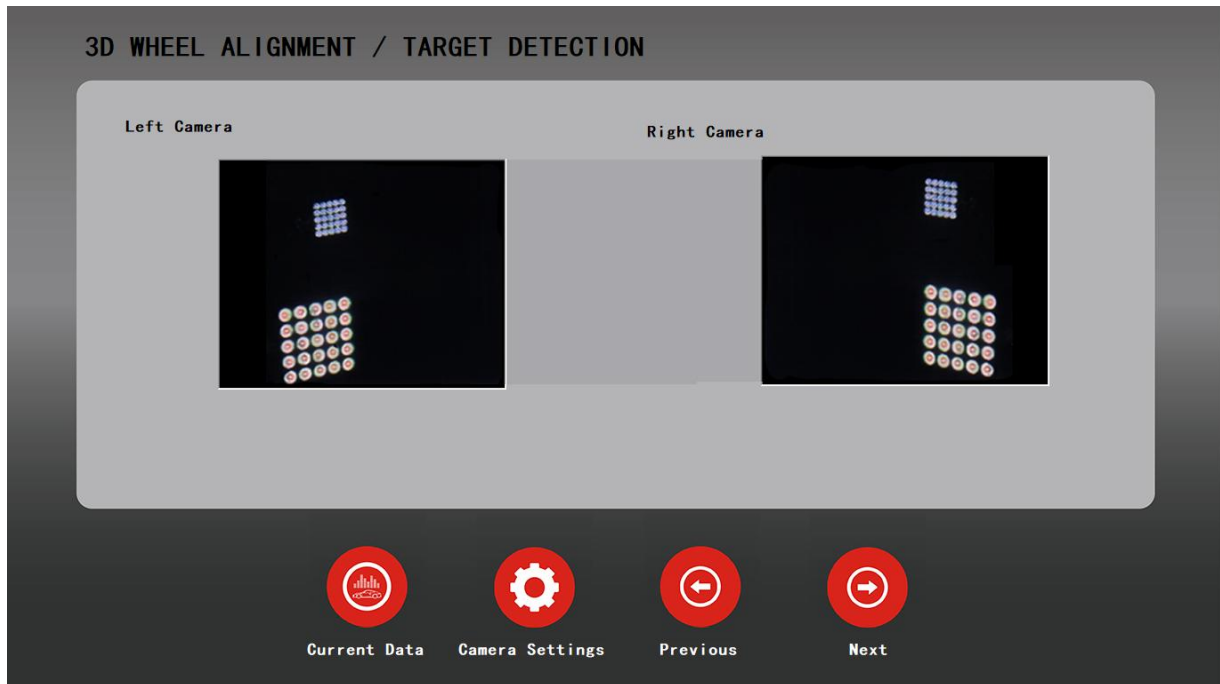

### 3. Select Model

Select the appropriate model based on the drop-down list.

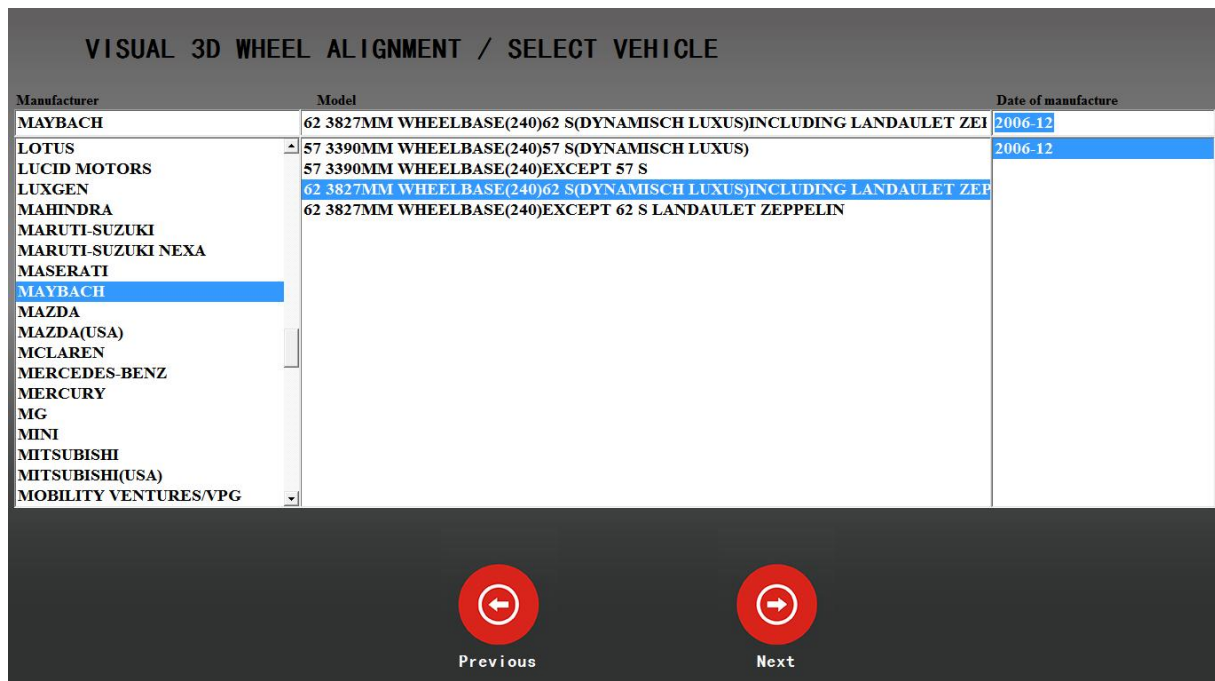



Double click on the model to enter the view to add the standard data of the model.

The page lists the standard data of each parameter of the front and rear wheels, including the total toe, camber, caster, Kingpin inclination angle and other parameters. The standard data of each parameter is a range value, and the page shows the minimum and maximum values of the parameter. As shown in the figure below:

**VISUAL 3D WHEEL ALIGNMENT / VEHICLE SPECIFICATION DATA**

Manufacturer	MAYBACH		Rim	14
Model	62 3827MM WHEELBASE (240) 62 S (DYNAMISCH LUXUS) INCLUDING LANDAULET ZEPPELIN		Add	
<b>FrontAxle</b>				
	Minimum		Maximum	
Total Toe	0.36		0.70	
Camber	-0.88		-0.22	
Caster	0		0	
KPI	0		0	
Setback	-0.6		0.6	
<b>RearAxle</b>				
Total Toe	0.58		0.82	
Camber	-2.00		-1.00	
Thrust angle	-0.25		0.25	
Date of manufacture				





Previous Next

## 4. Measurement Preparation

Follow the on-screen prompts to double-check that the following items are in place:

**VISUAL 3D WHEEL ALIGNMENT / PREPARATION**

① 

Check and lock the platform side skateboard

② 

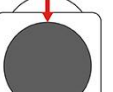

Place the tire block

③ 

Check and lock the platform corner plate

④ 

The target is targeted forward 10 degrees

Previous Next

## 5. Steering wheel centered and locked

Remove the turntable pins from the lift, then follow the on-screen prompts to turn the steering wheel to the center and lock the wheel using the square disk locking bracket.

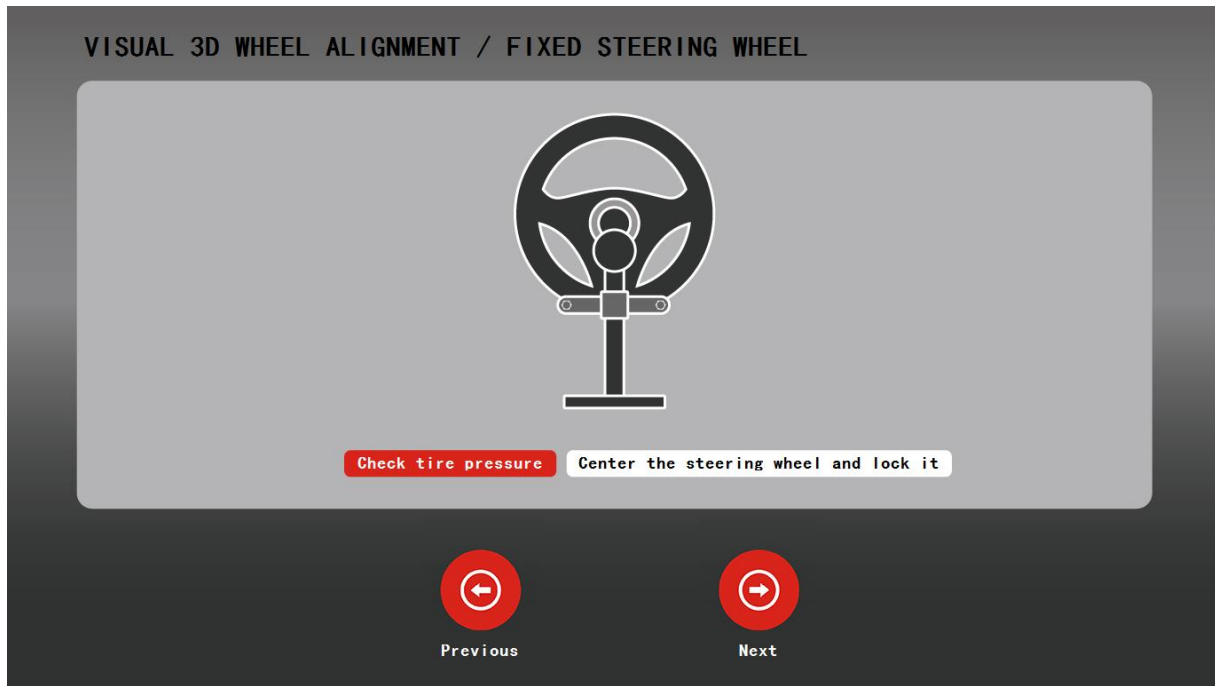

## 6. Dynamic Measurement-Toe & Camber

Operate according to the screen prompts, the vehicle backward and forward to push, display "STOP" when stopping the automatic recording, complete the automatic pop-up display measurement data.

Note: When pushing the car, the turntable pin must be fixed, the turntable rubber pads are installed, the measurement of the sliding plate is fixed.

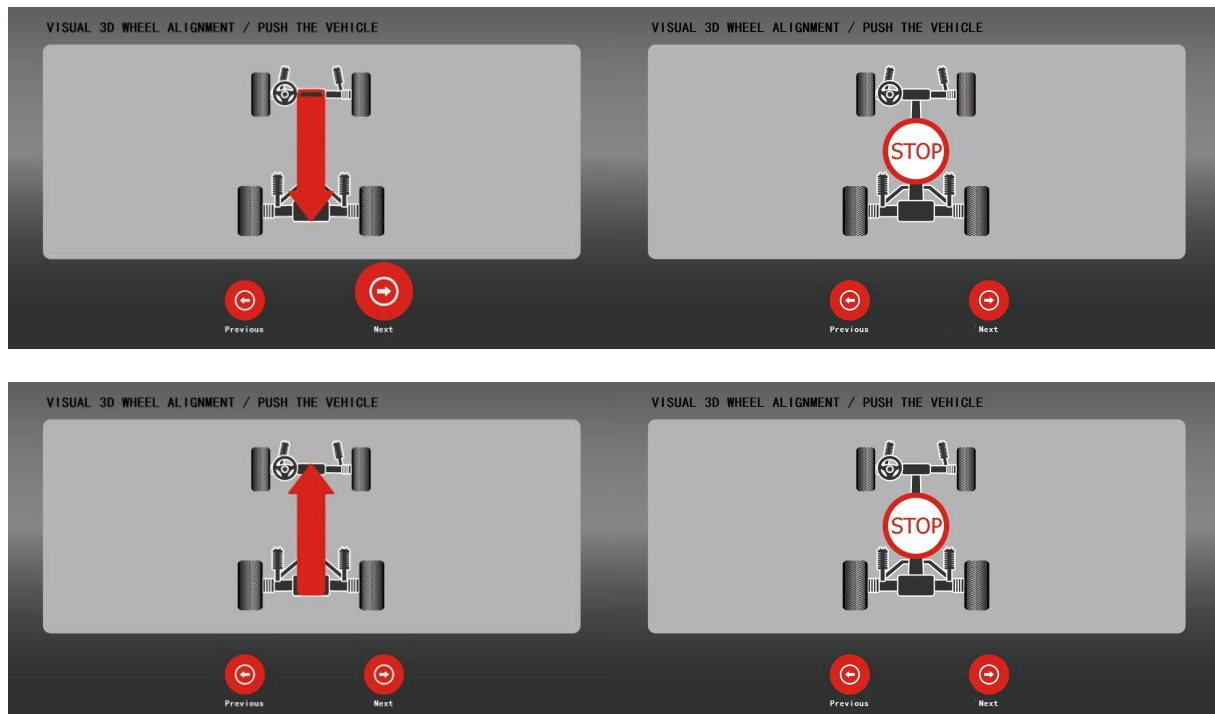

Toe and camber measurements:

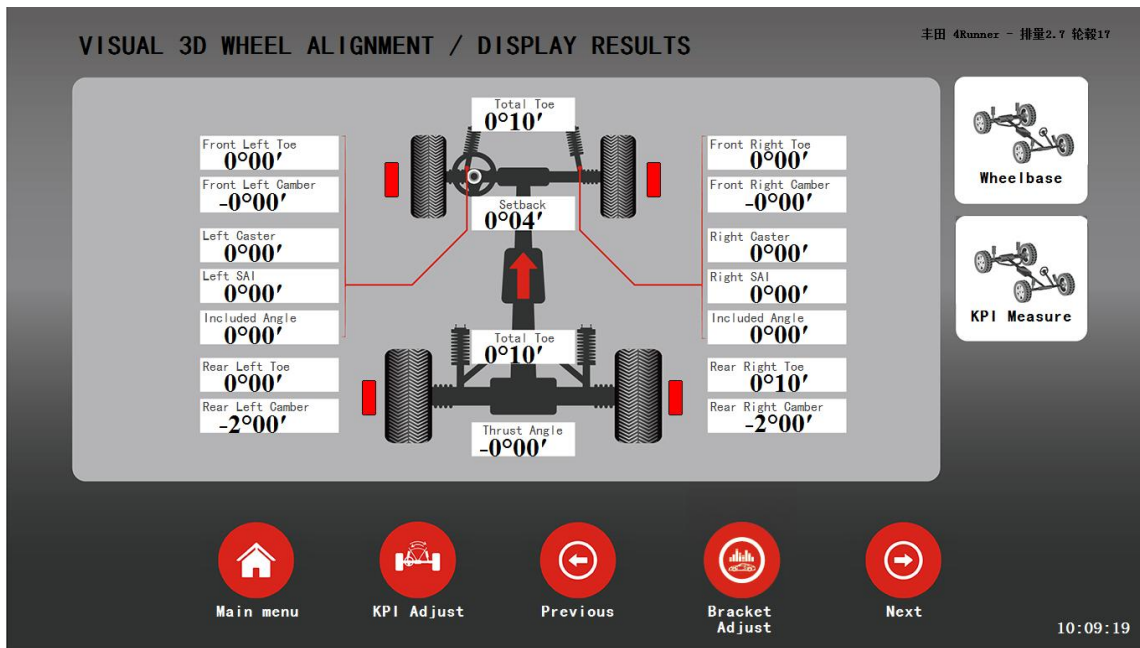

## 7. Kingpin inclination & Caster Measurement

Follow the prompts, before measuring, please move the steering wheel lock frame away, then install the brake holding tool. As following picture shows:

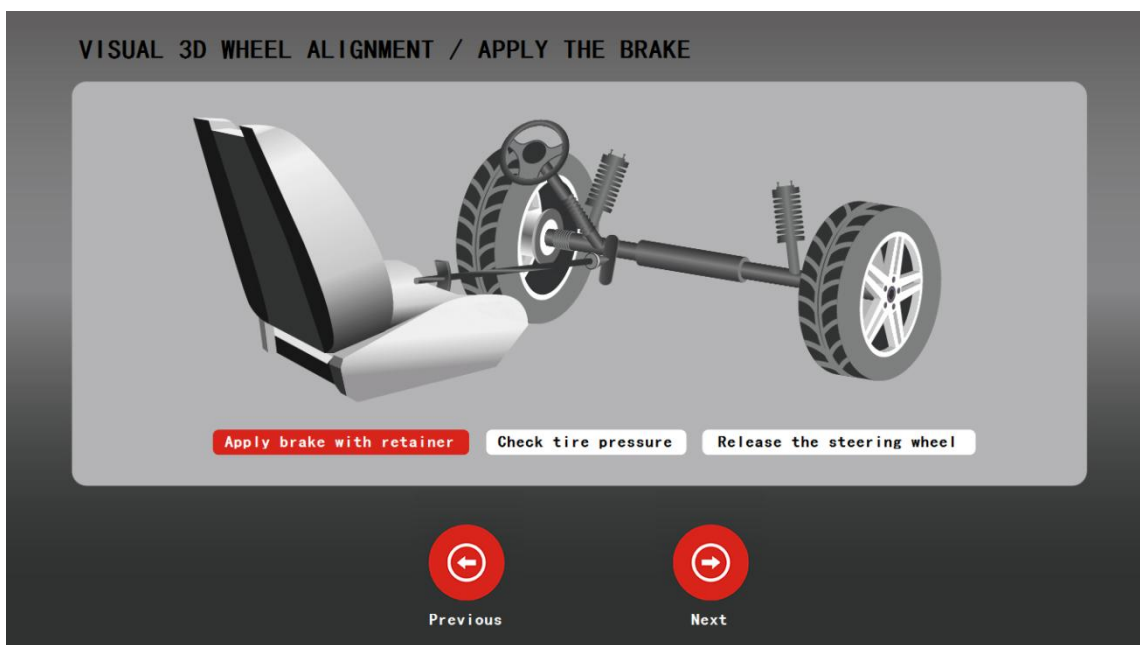

Follow the prompts and turn the steering wheel left, right and center.

Note: Make sure the vehicle's footbrake is locked when measuring, otherwise there is a deviation.

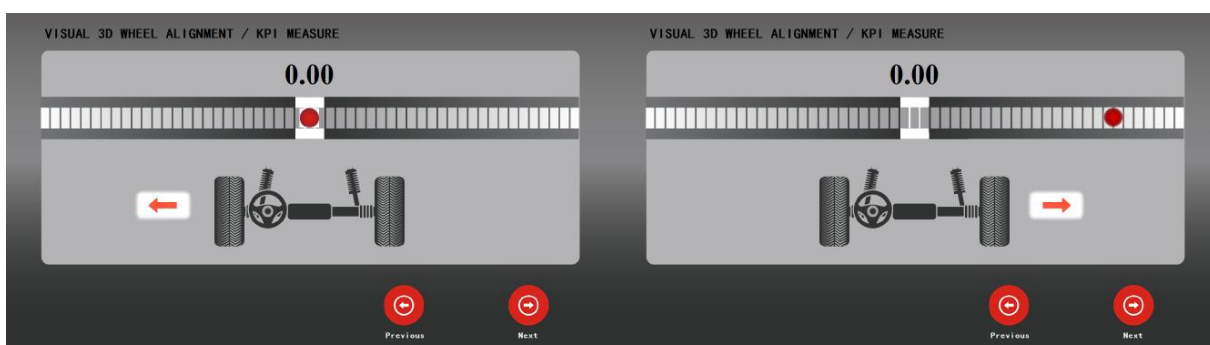

Kingpin inclination & Caster measurement results:

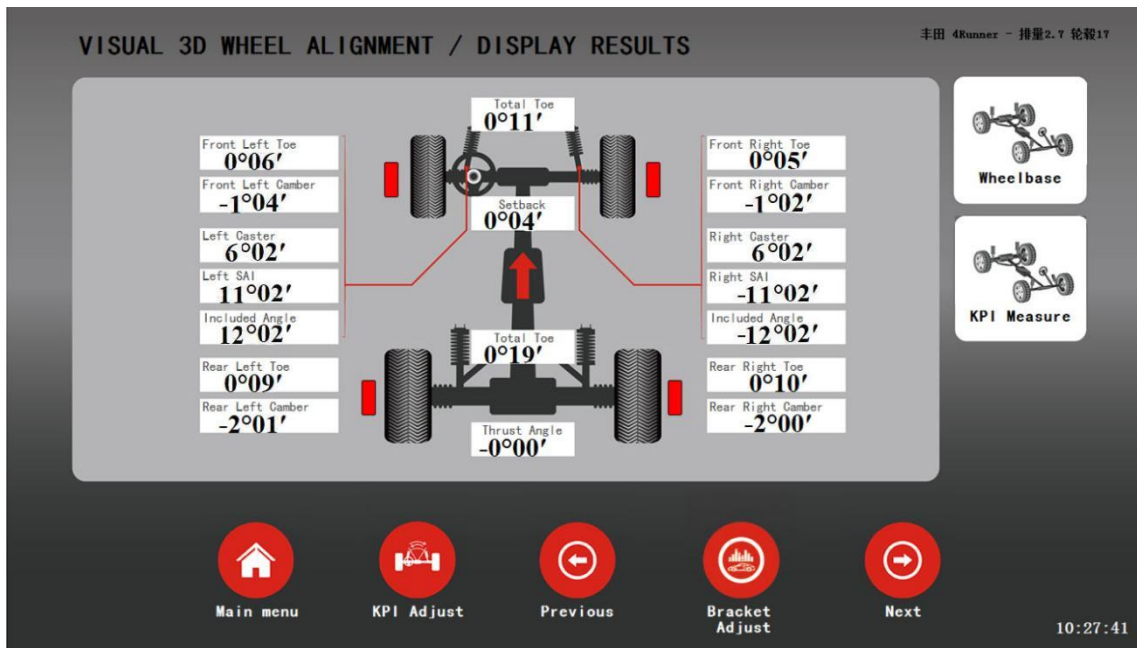

## 8. Additional function-Wheelbase and Wheel Width Measurement

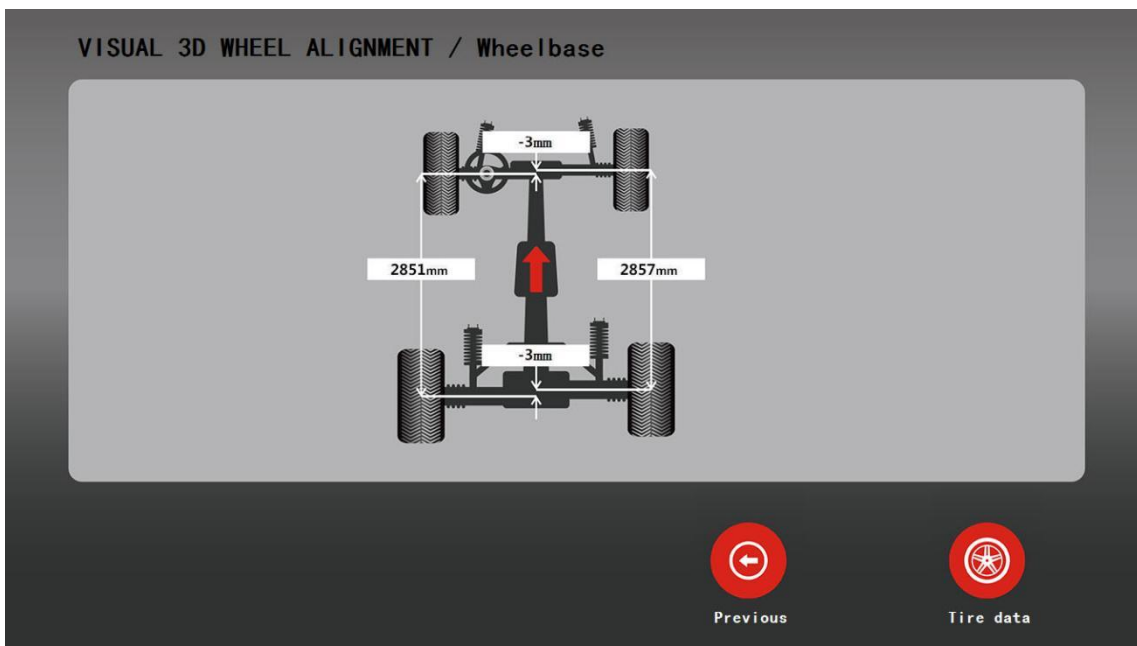

## 9. Analysis and Adjustment

Before four-wheel alignment, the car's condition should be checked one by one, including: tire eccentric wear, wheel hub deformation, chassis suspension deformation, unequal suspension height, uneven tire pressure, heavy objects on the vehicle, etc. These effects must be eliminated before alignment data measurement and adjustment.

Observe whether the rear wheel thrust angle is out of tolerance (the standard is  $\pm 0.25^\circ$ ). If it is out of tolerance, adjust the rear wheel toe.

Observe whether the kingpin inclination angle and kingpin caster angle are out of tolerance or the center difference exceeds  $0.5^\circ$ .

If the kingpin is out of tolerance, please first check whether the chassis components are deformed.

If the kingpin inclination is out of tolerance, chassis components usually need to be replaced;

If the kingpin caster is out of tolerance and cannot be adjusted, it needs to be corrected by adjusting and shaping the suspension.

An incorrect king pin will cause the vehicle to wander and affect the ability of the steering wheel to return to center.

Observe whether the front and rear wheel camber angles are out of tolerance. Generally, the center value exceeds  $0.5^\circ$  and must be adjusted, otherwise it will affect deviation and tire wear.

Observe whether the toe angle of the front and rear wheels is out of tolerance. Generally, if the center value exceeds  $0.3^\circ$ , it must be adjusted. Usually more than 90% of tires are caused by toe out.

Gradually adjust each angle to the standard value range.

### Rear wheel and front wheel adjustment:

Take the standard data as a reference, adjust the left and right side values to within the standard value respectively, and the screen color changes accordingly. The red numbers are the over differences, and the green numbers are the normal range.

The correct order of adjustment is to adjust the rear wheel first, then the front wheel; adjust the camber first, then the toe.

Specifically: ① rear wheel camber; ② rear wheel toe; ③ front wheel camber; ④ front wheel toe.

The rear wheel adjustment:

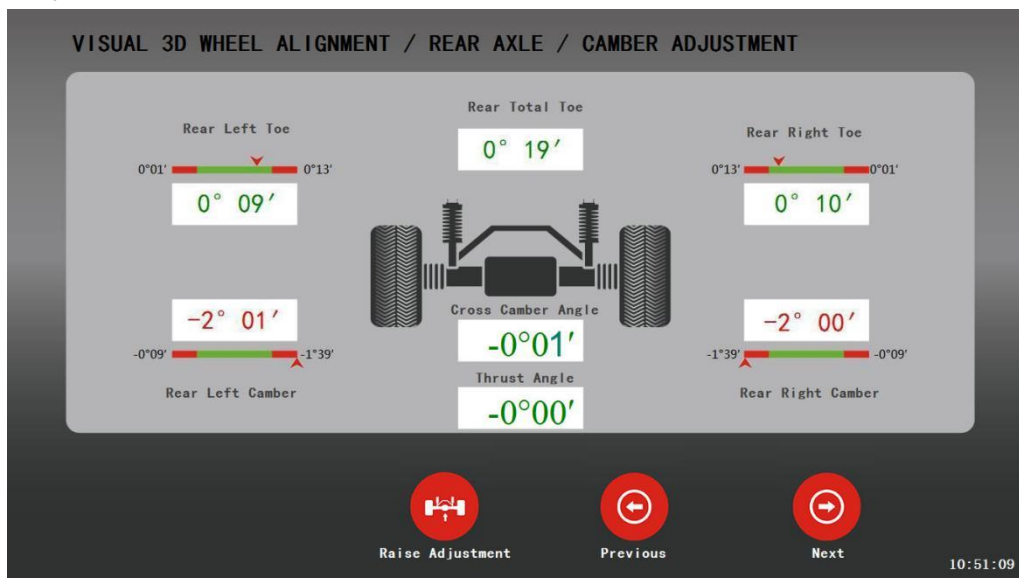

The front wheel adjustment:

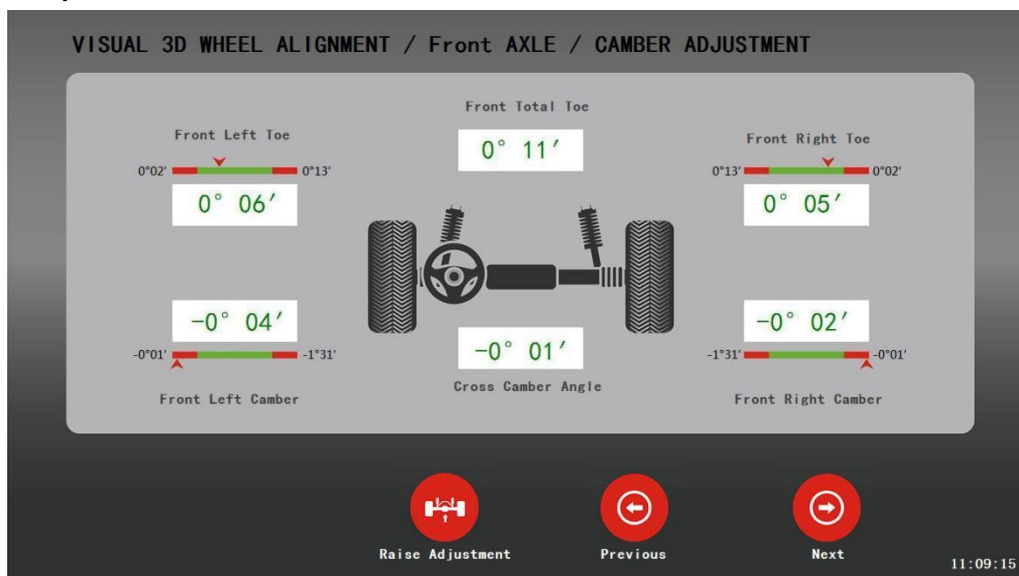

The kingpin adjustment:

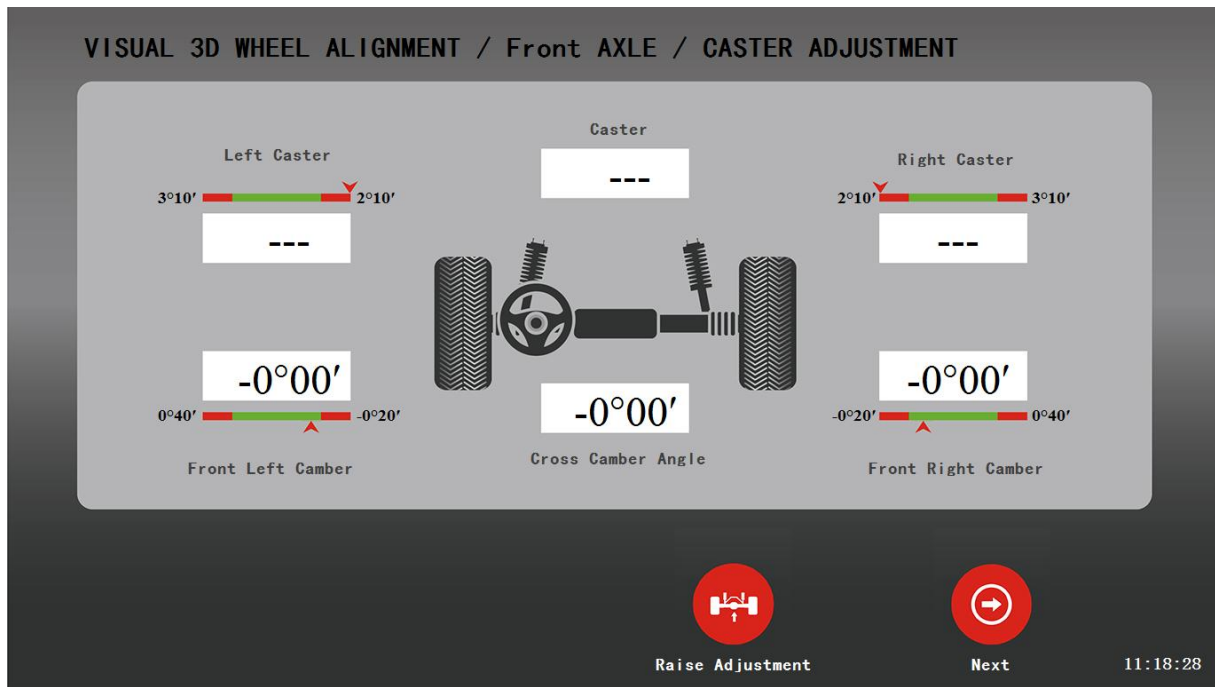

## 10. Print Result

When the adjustment is complete, enter the relevant data to print the result.

After the adjustment work, please place the target and clamp at the machine hangers.

Finally, please conduct sufficient and necessary vehicle road tests. If there is the problem with the driving status of the vehicle, it is necessary to check and analyze the cause before making adjustments according to the situation.

## Chapter IV. Additional Software Functions

### 1. Chassis wheelbase and wheelbase size detection

This function assists the technicians to analyze the condition of the chassis.

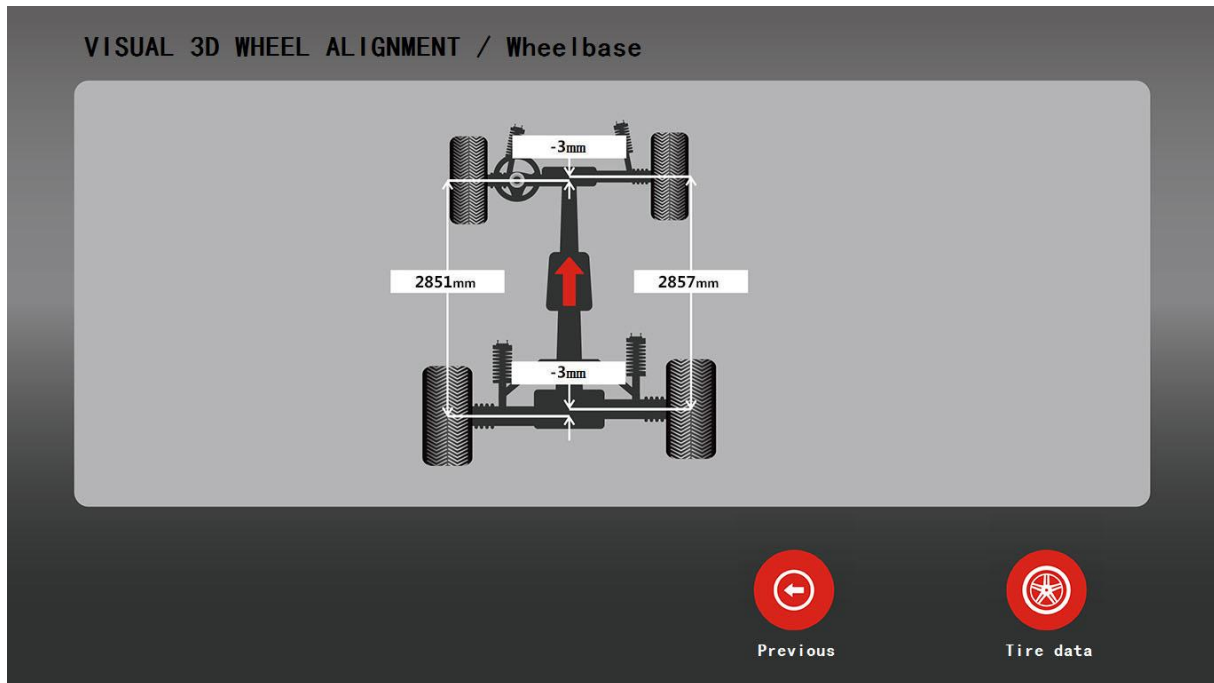

### 2. Tire actual size inspection

This function assists the technicians to analyze the actual size of the overall tire and then analyze the driving status of the car.

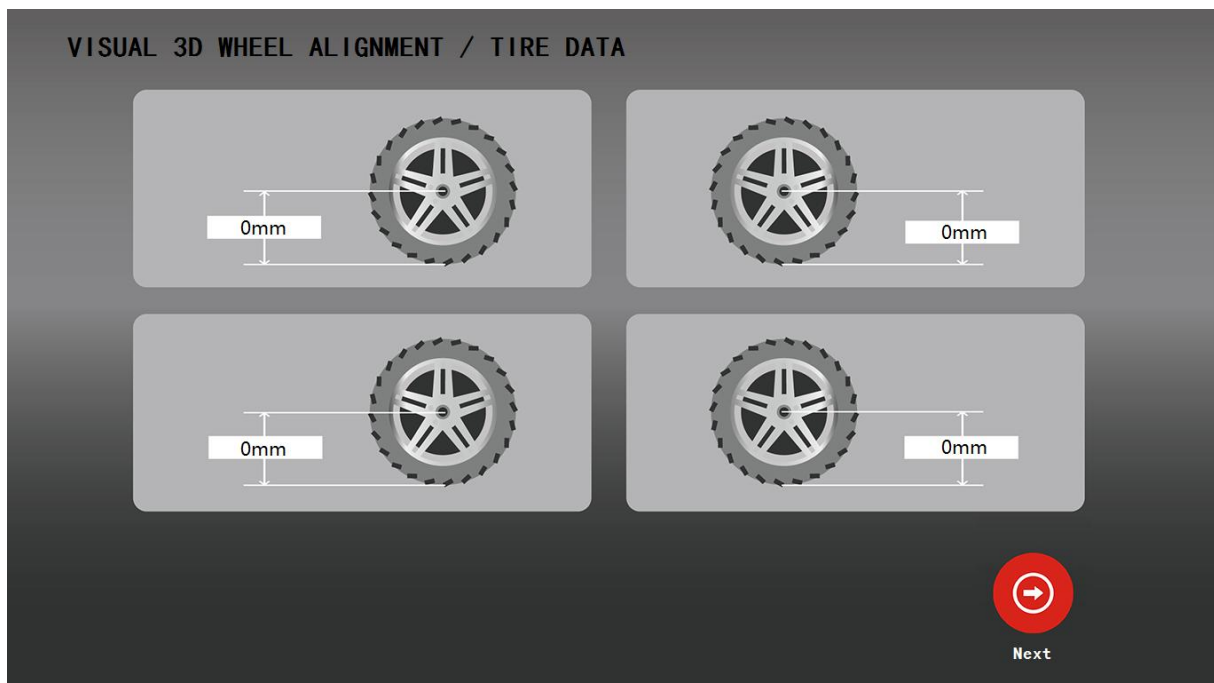

### 3. Engine bracket adjustment function

The engine bracket adjustment function assists the technicians in real-time observation of vehicle alignment data changes when installing the engine, so that engine installation does not affect vehicle alignment.

Engine bracket adjustment interface:

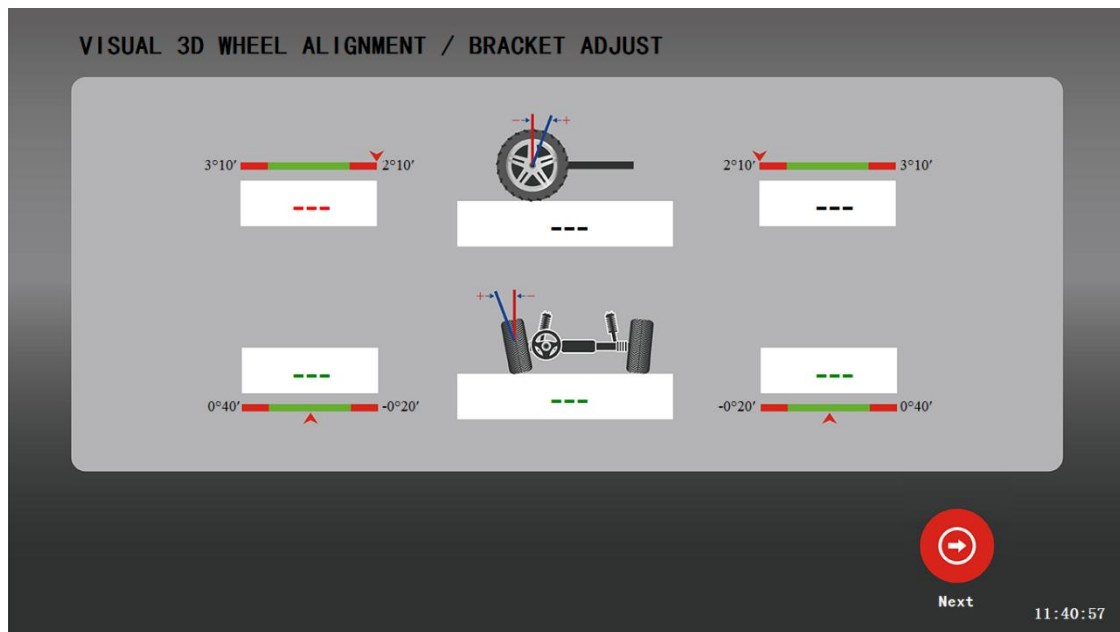

## Chapter V Software Setting Function

Click the Settings button on the homepage to enter the setting page, where to set the following functions:

Alignment mode: geometric centerline positioning and thrust line positioning;

Toe unit switching: mm and angle minutes;

Unit of division degree: 100 minutes = 1° or 60 minutes = 1°;

Language switching: Chinese and English;

Home page move mouse to select settings button.

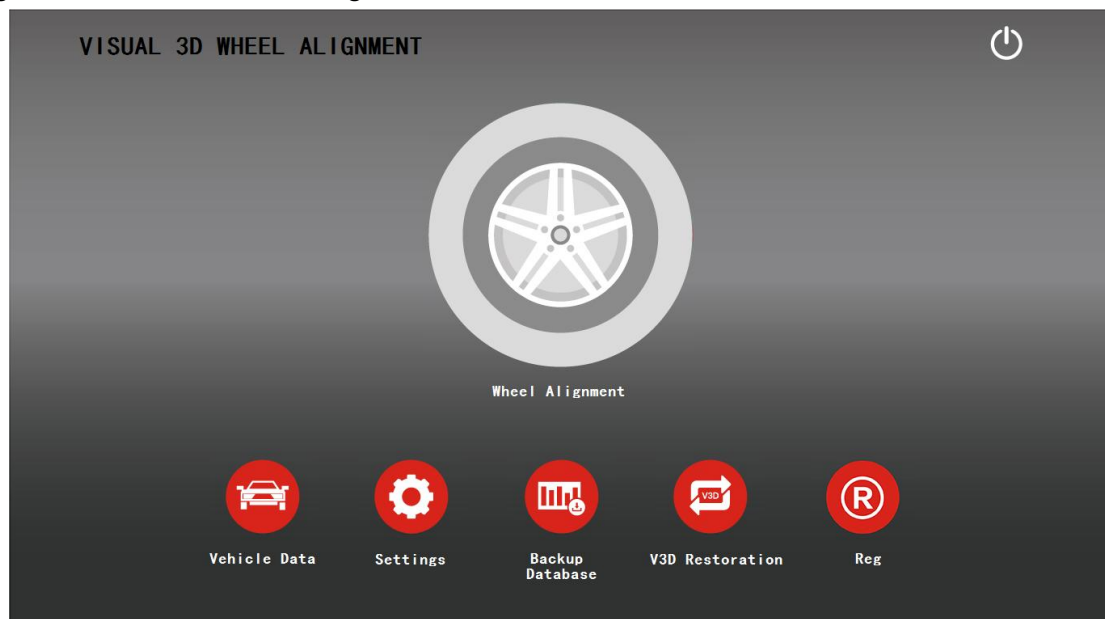

Setting interface

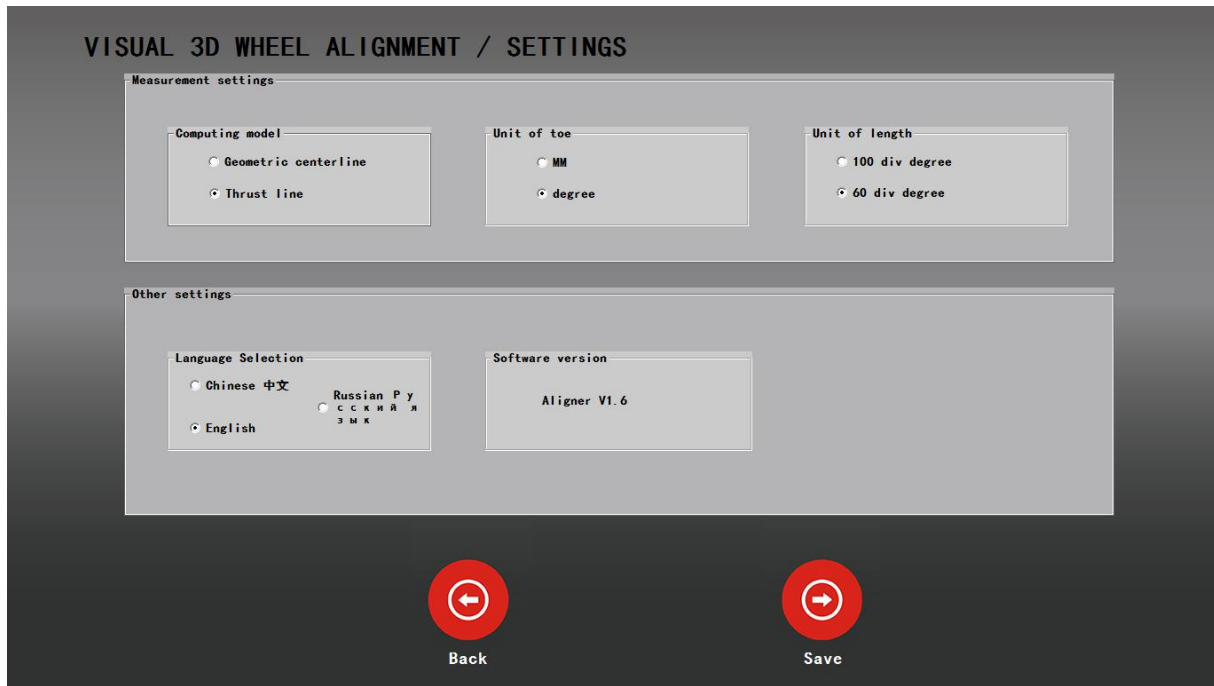

## Chapter VI Database Maintenance

Move the mouse to select and click the button "Vehicle Data" on the homepage (as shown below) to directly enter the vehicle's database maintenance interface to query, search and edit the vehicles data.

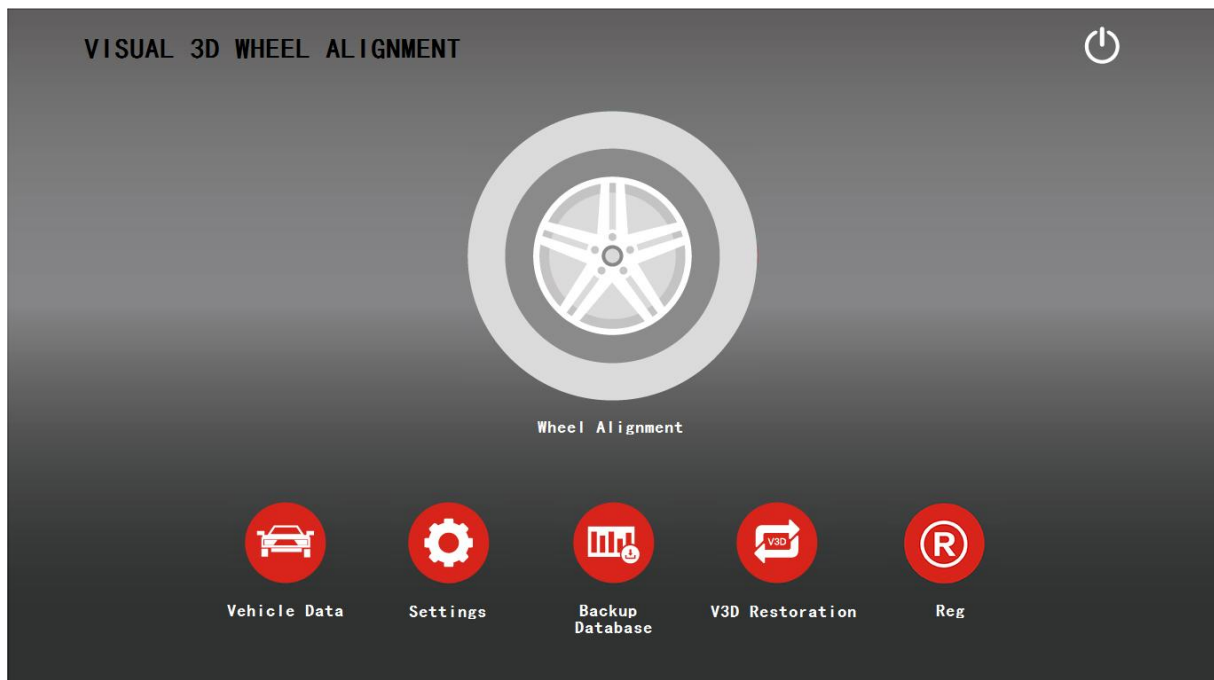

Vehicle database maintenance interface:

Query or search vehicle alignment data based on vehicle brand, car manufacturer, model, year of manufacture and other information.

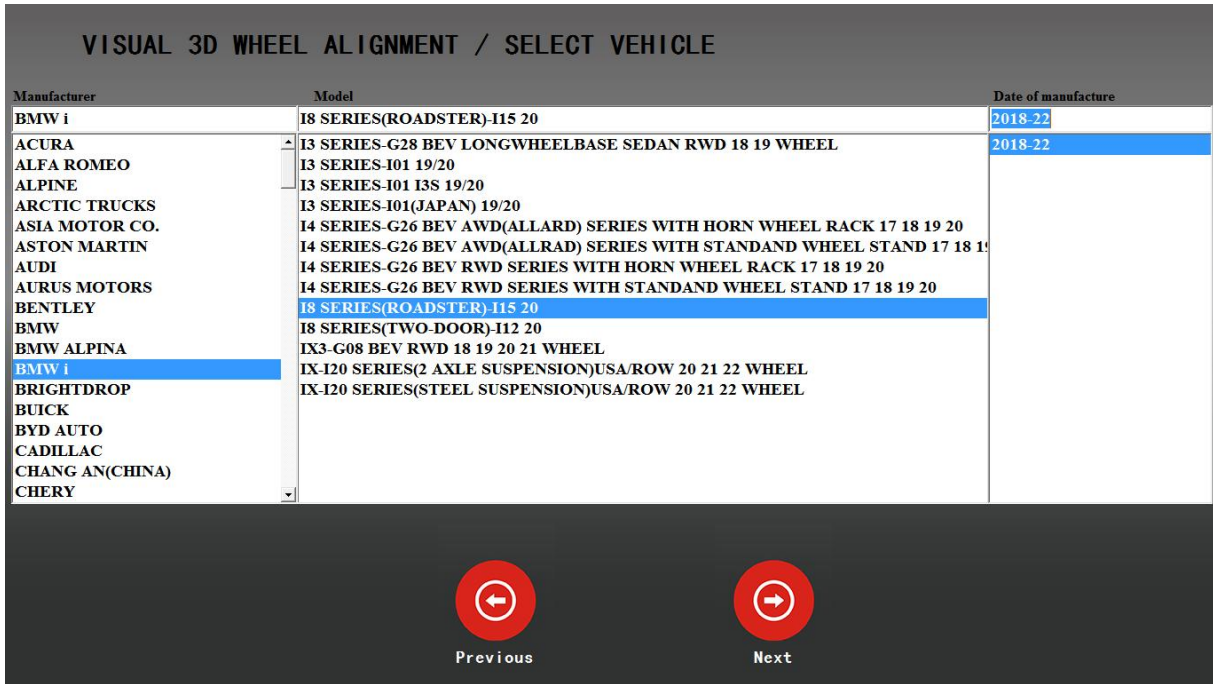

Data query editing interface:

In the previous step, after selecting the model and year of manufacture, double-click the data to enter the following editing interface, where can edit and delete the selected data, and add model data of other brands, models, and manufacturing years.

Note: When editing data, the units on the current case page are based on degrees and minutes. Please refer to Chapter V Software Settings for unit switching.

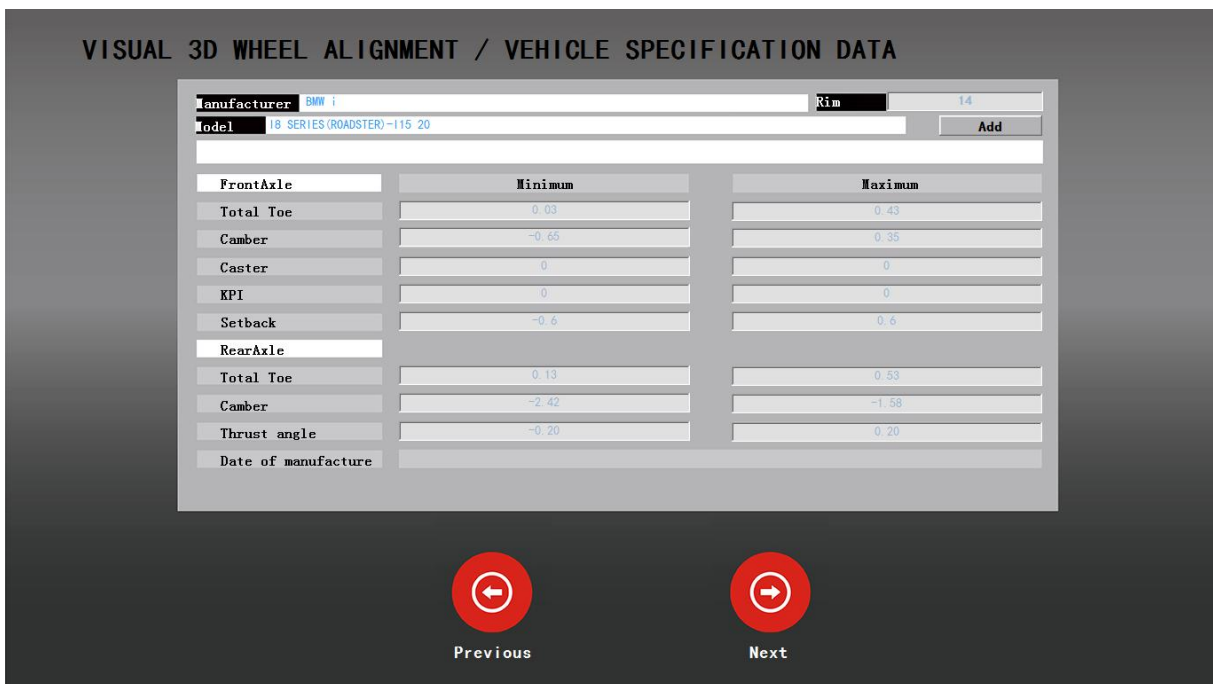

## Chapter VII. Security information

The four-wheel aligner must be used by a professionally trained and skilled automotive technician. The safety information in this manual is intended primarily to alert the operator that he or she must take care not to jeopardize his or her own safety and the safety of others in the work area when using the equipment. In the course of servicing

automobiles, which vary widely in terms of servicing skills, techniques, tools and parts, it is impossible for the equipment manufacturer to anticipate every situation and provide appropriate advice or safety information. It is important for the technician using the equipment to be aware of safety information regarding the repair and operation of automobiles, and to use proper repair and adjustment methods to accomplish automotive four-wheel alignment. Prior to using the equipment, the operator must have a complete understanding of the vehicle system to be serviced, as well as a complete understanding of the lifter's operating and safety features, and have the proper tools to complete the four-wheel alignment.

When using a four-wheel aligner or shop equipment, basic safety procedures must be followed including:

Carefully read all safety tip information.

Do not touch hot metal parts that could cause burns.

When equipment power cables are damaged, do not operate the equipment until it has been inspected by a service professional.

Do not allow cables to hang over the edges of tables, workbenches, or come in contact with hot manifolds or moving fan blades.

Use cables or outlets rated equal to or greater than the rated current of the equipment; cables rated less than the rated current of the equipment can cause overheating or burning.

Always unplug the unit when not in use. Do not use pulling on the power supply to remove the plug from the outlet, but grasp the plug handle to do so.

When storing the unit, loosely wrap the cable around the unit.

The power supply of the four-wheel aligner requires AC220V~AC240V, 10A, 50HZ, and must use a three-terminal power socket of 10A or more.

Measuring lens, target and clamp of the four-wheel aligner are all precision measuring parts, which should be lightly held and put down in the process of using.

In order to optimize the safety and performance of the computer system of the four-wheel aligner, please do not install other software at will.

## Chapter VIII. Equipment Package

The wheel aligner is a precision measuring instrument and is packaged in wood. When transporting and unpacking, please pay attention to the fragile, anti-collision, rain proof, and other signs.



## Chapter IX. Equipment Handling

### Handling Precautions:

Equipment in the process of loading and unloading, be sure to use professional loading and unloading tools to gently hold and place. (For example, forklift)

In the process of handling must pay attention to not violent shaking.

For electronic equipment must be good moisture-proof, moisture-proof, high temperature, etc., equipment loading must be covered with a raincoat.



## Chapter X. Environment for Storage & Use of Equipment

Because the four-wheel aligner belongs to high-precision electronic measuring equipment, the storage and use environment of the equipment is very important.

### Equipment storage or use environment:

Indoor or similar indoor environment;

Ambient temperature between 0°C~40°C;

Ambient air pressure between 86KPa~106KPa;

Relative humidity not greater than 80%;

Power supply voltage is single-phase AC220V~AC240V,50HZ.

### Avoid storage or use in the following environment:

Places exposed to direct sunlight or baked by high temperature sources;

Environments with drastic temperature changes;

Dusty or humid places;

Environments with strong electric or magnetic fields;

Where corrosive, flammable or explosive gases or chemical gases are present.

## Chapter XI Four-wheel Aligner Maintenance Precaution

The daily maintenance of the four-wheel aligner is very important, the following maintenance precautions.

Electricity safety equipment due to automotive repair shop high-power equipment more, in order to better protect the normal operation of the majority of customers. Our company recommends the use of four-wheel aligner users are best equipped with a small voltage regulator to achieve voltage stability, reduce the loss of electronic components of the equipment; if there is often a power outage problem, in order to take into account the security of the data, it is recommended that the best computer is equipped with a UPS power supply.

The main components of the equipment to do a good job of dust-proof, waterproof and moisture-proof treatment, the equipment must be away from the car wash station, while the accumulation of dust inside the computer may cause the computer to respond slowly, can not be turned on, blue screen and other malfunctions, so in the automobile workshop, auto parts city, the street road stores must do a good job of dust-proof treatment of the above components, the equipment is used in a timely manner to close the door plate of the chassis.

3D target use is completed in a timely manner after hanging back on the hanger, while using a soft dry cloth to wipe clean, should avoid surface scratches, avoid direct sunlight, placed in a cool ventilated place. The clamp jaws must be replaced if there is serious wear and tear to avoid scratching the rim. Regularly lubricate the clamp screw and slide bar to ensure its flexibility.

The overall requirements of the working environment of the equipment: the ideal working temperature of the computer is 0 °C ~ 40 °C, the ambient temperature is too low or too high, easy to cause the computer can not start normally or frequent crash; the ideal working humidity of 30% ~ 80%, high humidity is easy to cause short-circuit, too low is easy to generate static electricity, please do a good job of ventilation and heat dissipation!

## Chapter XII Common Failure and Solution

fault description	possible causes	treatment
1、 Computer mainframe and monitor indications do not light up	a. The power switch is not turned on. B. Power supply is not plugged in. c. Power cable is damaged.	Check power outlets, fuses and cable connections.(NOTE: the electric job is dangerous, must be operated by professionals)
2、 Monitor screen does not display	a. The monitor is not turned on. b. Problems with the cable connecting the monitor to the computer host. c. The signal source is wrong d. The monitor is damaged.	a. Turn on the monitor switch. b. Check the connection between the computer and the host computer, if the cable is damaged, it must be replaced. c. Re-choose the signal source by remote controller. d. Contact after-sales service.
3、 Cannot print or poor print quality	a. The printer is not turned on. b. Print paper is used up. c. Printer installation problems. d. The printer cartridge no ink.	a. Turn on the printer power. b. Install the print paper. c. Reinstall the printer driver. d. Replace the ink cartridge.
4、 Computer host can't find the camera	a. Problems with camera installation. b. Problems with the connection cable between the camera and the computer host. c. Camera failure.	a. Reinstall the camera driver. b. Check the connection between the camera and the computer host, if the cable is damaged, it must be replaced. c. Contact after-sales service to replace

		the camera.
5、 Flash board light does not come on	<p>a. The 12V switching power supply is not energized.</p> <p>b. The connection cable between the flash board and the switching power supply is faulty.</p> <p>c. 12V switching power supply is damaged.</p> <p>d. The flash board transmitter tube is burned out.</p>	<p>a. Turn on the 12V switching power supply.</p> <p>b. Check the cable wire, damage needs to be replaced.</p> <p>c. Replace the 12V switching power supply.</p> <p>d. Replace with new flash board.</p>
6、 Camera fails to capture target board	<p>a. Dirt on the surface of the target plate.</p> <p>b. There is an obstacle blocking between the camera and the target plate.</p> <p>c. The camera brightness is not enough</p> <p>d. The camera does not work.</p> <p>e. The flash board does not work.</p>	<p>a. Clean the dirt with special cleaning tools.</p> <p>b. Troubleshoot obstacles between the imager and the target plate.</p> <p>c. Enter the target detection-camera setting-adjust the brightness-save.</p> <p>d. Resolve according to fault description 4.</p> <p>e. Solve according to fault description 5.</p>
7、 The camera works and captures the target plate, but the cart arrow does not appear	The "Re-measure" button was not clicked during measurement.	Go back to the previous step and click on the "Re-measure" button, then click on "Next".
8、 The left and right cart arrows keep blinking and jumping during the cart pushing process	The calibration file is missing in D:\ Program Files (x86)\Aligner.	Contact the after-sales service to make up the documents.