

# 71.DWB

## WHEEL BALANCER INSTRUCTION & MAINTENANCE MANUAL



**Jimmy Industrial Pty Ltd**  
**5 Cord St**  
**Dudley Park, 5008**  
**Ph: (08) 8269 9700**  
**W: [www.jimmytools.com.au](http://www.jimmytools.com.au)**  
**E: [sales@jimmytools.com.au](mailto:sales@jimmytools.com.au)**



Read this entire manual carefully and completely before installation or operation of the wheel balancer

## CATALOGUE

1. Introduction .....	1
2. Specification and Features .....	1
2.1 Specification .....	1
2.2 Features .....	1
2.3 Working Environment .....	1
3. The Constitution of Dynamic Balancer .....	1
3.1 Machine .....	1
3.2 Electricity system .....	1
4. Installation of Dynamic Balancer .....	2
4.1 Opening and Checking .....	2
4.2 Installing machine .....	2
4.3 Installing hood .....	2
4.4 Installing screw stud of drive axis .....	2
5. LED display control panel and function keys .....	3
6. Installation and Demounting of the Wheel .....	4
6.1 Checking the wheel .....	4
6.2 Installing the wheel .....	4
6.3 Demounting the Wheel.....	4
7. The input methods of date of rim.....	4
7.1 The power-on state of the machine .....	4
7.2 Date of wheel input method for normally dynamic balance mode.....	4
7.3 The date input method of ALU-S mode: .....	5
8. Calibration of measure scale .....	6
8.1 Calibration of rim distance scale .....	6
8.2 Calibration of diameter scale .....	6
9. The Self-calibrating of Dynamic Balancer.....	7
10. The Balancing Operation of Wheel .....	7
10.1 Balance mode change operation .....	7
10.2 Normal balance mode operation process .....	8
10.3 Static balance (ST) operation process.....	8
10.4 The operation process of M1 to M2 mode.....	9
10.5 ALU-S balance mode operation process.....	9
★ Process of manual stickup counterweight .....	9
★ Process of automatic stickup partition Counterweight.....	9
10.6 The of counterweight hide-stick mode .....	10
★ Split manual stick operation .....	10
★ Split automatic stick operation .....	11
10.7 Recalculation .....	11
11. Imbalance optimize .....	11
12. Gram-Oz conversion operation.....	12
13. INCH and MM conversion operation.....	12
14. Protect hood function and protect setting .....	12
15. Other function settings .....	13
15.1 Minimum value display settings .....	13
15.2 Key-tone clue on function settings.....	13
15.3 Display monitor brightness settings .....	13
16. Machine self test function .....	13
16.1 LED and indicator light check .....	13

- 16.2 Position sensor signal check ..... 14
- 16.3 Distance sensor signal check ..... 14
- 16.4 Diameter sensor signal check..... 14
- 16.5 Press sensor signal check ..... 14
- 17. Safety Protections and Trouble Shooting.....14
  - 17.1 Safety protection ..... 14
  - 17.2 Trouble shooting ..... 14
- 18. Maintenance .....16
  - 18.1 The daily maintenance of non- professionals..... 16
  - 18.2 The maintenance of professionals..... 16
- 19. Trouble-error code list .....17
- 20. Power supply layout diagram.....18
  - 20.1 220 V Connection ..... 18
  - 20.2 380 V Connection ..... 18
- 21. Exploded drawings .....19
- 22. Spare parts list .....22
  - S Version Exploded drawings and spare parts list..... 23
  - Accessories list..... 24
  - Attach figure 1      System circuit diagram ..... 25

## 1. Introduction

An imbalanced wheel will make the wheel jump and steering wheel wobble while driving. It can baffle the driver to drive, aggrandize the cleft of combine area of steering system, damage the vibration damper and steering parts, and increase the probability of the traffic accidents. A balanced wheel will avoid all these problems.

This equipment adopts the new LSI (Large Scale Integrated circuit) to constitute the hardware system that acquires processes and calculates information at a high speed.

Read the manual carefully before operating the equipment to ensure normal and safe operation. Dismantling or replacing the parts of equipment should be avoided. When it needs repairing, please contact with technique service department. Before balancing, ensure the wheel fixed on the flange tightly. Operator should wear close-fitting smock to prevent from hanging up. Non-operator does not start the equipment.

No use while beyond the stated function range of manual.

## 2. Specification and Features

### 2.1 Specification

- Max wheel weight: 65kg
- Motor power: 200W
- Power supply: 220V/50Hz
- Balancing precision:  $\pm 1g$
- Rotating speed: 200r/min
- Cycle time: 8s
- Rim diameter: 10"~24"(256mm~610mm)
- Rim width: 1.5"~20"(40mm~510mm)
- Noise: <70dB
- Net weight:98kg
- Dimensions: 915mm×760mm×1180mm

### 2.2 Features

- Adopt 9 LED display, it has flexible indicator operating function.
- Various balancing modes can carry out counterweights to stick, clamp, or hidden stick etc.
- Input data of rim automatically by measure scale.
- Intelligent self-calibrating and measure scale self-labeling function.
- Self fault diagnosis and protection function.
- Applicable for various rims of steel structure and duralumin structure.

### 2.3 Working Environment

- Temperature: 5~50°C
- Height above sea level:  $\leq 4000m$
- Humidity:  $\leq 85\%$

## 3. The Constitution of Dynamic Balancer

Two major components of the dynamic balancer are: machine and electricity:

### 3.1 Machine

The part of machine consists of support, swing support and main axis; they are together fixed on the frame.

### 3.2 Electricity system

1. The microcomputer system is made up of the LSI such as new high speed MCU CPU system and keyboard.
2. Automatic measure scale.
3. Testing speed and positioning system consists of gear and opto-electronic

- coupler.
- 4. Two-phase asynchronous motor supplies and controlling circuit.
- 5. Horizontal and vertical pressure sensor.
- 6. Hood protection.

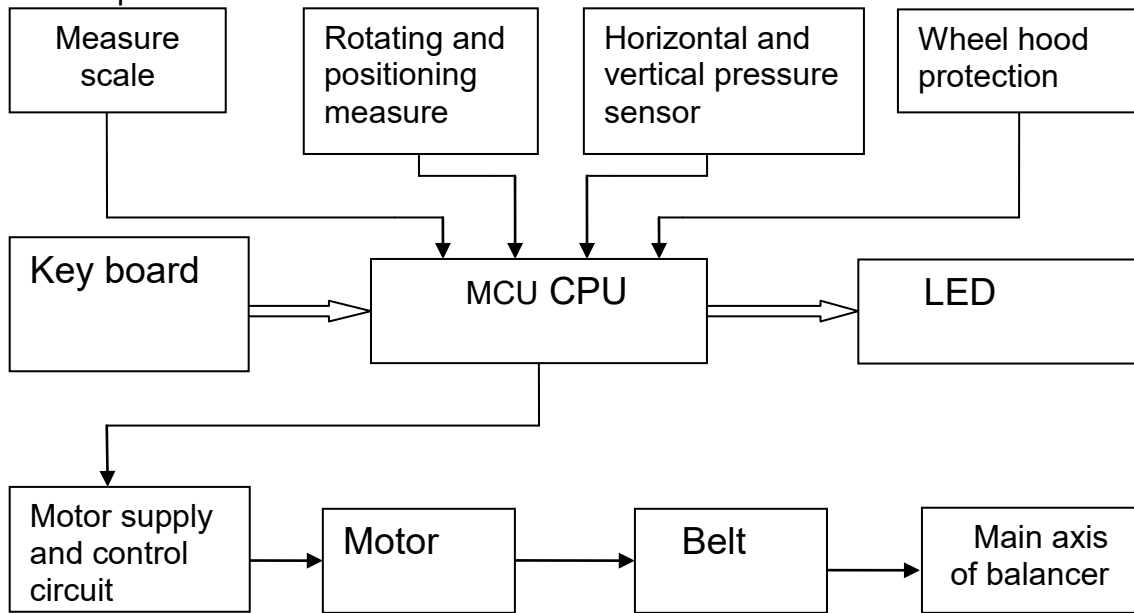

Figure 3-1

#### 4. Installation of Dynamic Balancer

##### 4.1 Opening and Checking

Open the package and check whether there are damaged parts. If there are some problems, please do not use the equipment and contact with the supplier. Standard accessories with equipment are shown as follow:

- Screw stud of drive axis 1
- Balancing pliers 1
- Allen wrench 1
- Measure caliper 1
- Locking nut 1
- Adapter (cone) 4
- Counterweight (100g) 1
- Protection hood (optional) 1

##### 4.2 Installing machine

4.2.1 The balancer must be installed on the solid cement or similar ground, unsolidified ground can bring measuring errors.

4.2.2 There should be 50cm around the balancer in order to operate conveniently.

4.2.3 Nail anchor bolts on the base's mounting hole of balancer to fix the balancer.

##### 4.3 Installing hood

Install the frame of hood on the equipment (optional): plug the pipe of protection hood into the hood shift (behind the cabinet), then fix with M10×65 screws.

##### 4.4 Installing screw stud of drive axis

Install screw stud of drive axis on the main axis with M10 × 150 socket bolt, then screw down the bolt. (Refer to figure 4-1)

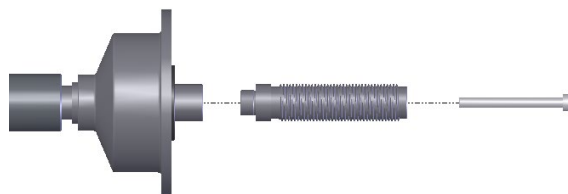
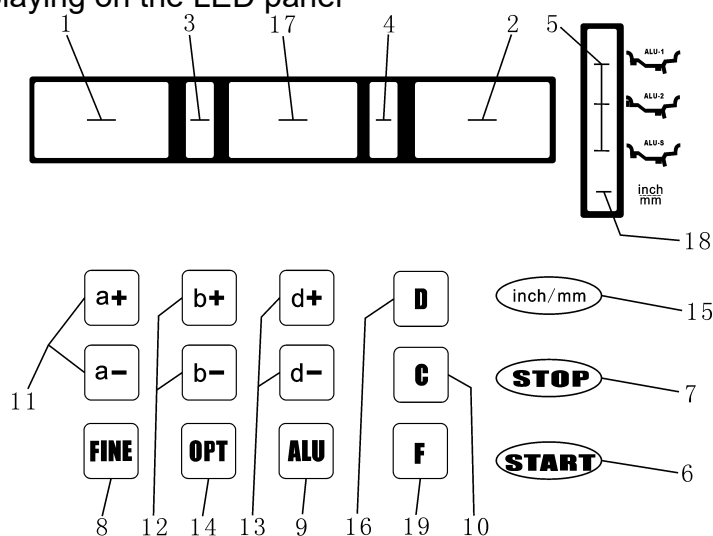

**Figure 4-1**

**(Notice:** a wheel can be installed on the main axis before screwing down, then hold the wheel by hands in order to prevent the main axis revolving together with the bolt.)

**5. LED display control panel and function keys**

Figure 5-1 displaying on the LED panel



**Figure 5-1**

**Part name of panel and signification**

- 1-Digital readout, amount of imbalance, inside or “DISTANCE” dimension
- 2-Digital readout, amount of imbalance, outside or “DIAMETER” dimension
- 3-Digital readout, position of imbalance, inside
- 4-Digital readout, position of imbalance, outside
- 5-Indicator, “ALU” correction mode selected
- 6-Push button, cycle start
- 7-Push button, emergency and selection of special functions
- 8-Push button, unbalance display pitch and threshold
- 9-Push button , selection of “ALU” mode of correction
- 10- Push buttons for recalculation and self-calibration
- 11- Push buttons, manual DISTANCE (a) setting
- 12- Push buttons, manual WIDTH (b) setting
- 13- Push buttons, manual DIAMETER (d) setting
- 14- Push button, optimization of unbalance and split unbalance
- 15- Selection of dimensions, inch/mm
- 16- Push button, self-diagnostics, self-calibration and split unbalance
- 17- Digital readout, “STATIC” unbalance or “WIDTH” dimension
- 18- Indicator of dimensions in mm
- 19- Selection, “STATIC” or “DYNAMIC” correction

**N.B. Only use the fingers to press push buttons. Never use the counterweight pincers or other pointed objects.**

## 6. Installation and Demounting of the Wheel

### 6.1 Checking the wheel

The wheel must be clean, none sand or dust on it, and remove all the primal counterweights of the wheel. Check the tyre pressure whether up to the rated value. Check positioning plane of rim and mounting holes whether deformed.

### 6.2 Installing the wheel

6.2.1 Select the optimal cone for the center hole when there is center hole on the rim.

6.2.2 Two ways of installing the wheel: A. positive positioning; B. negative positioning.

6.2.2.1 Positive positioning (refer to figure 6-1):

Positive positioning is commonly used. It operates easily, and it is applicable for various rims of common steel structure and thin duralumin structure.

6.2.2.2 Negative positioning (refer to figure 6-2):

Negative positioning is used to ensure the inner hole of steel rim and main axis is positioning accurately when the outside of wheel deforming. Apply for all the steel rims, thick steel rims especially.

6.2.3 Install wheel and cone on main axis. Ensure the cone can clamp the wheel before screwing handle. Wheel can rotate after screwing down.

### 6.3 Demounting the Wheel

6.3.1 Demount the handle and cone.

6.3.2 Put the wheel up, and then take it down from main axis.

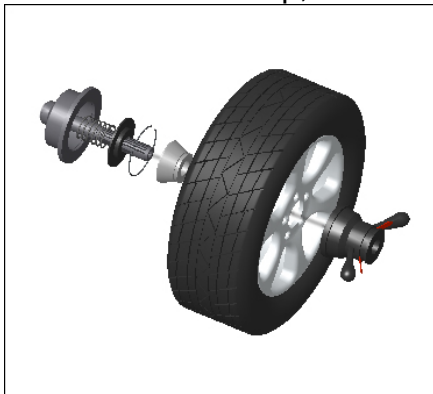

Figure 6-1

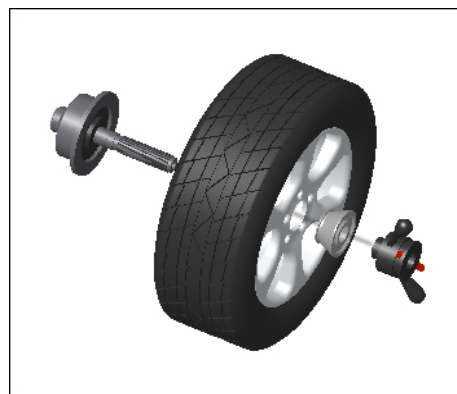

Figure 6-2

**Note: do not slip wheel on main axis to prevent main axis from scuffing while installation and demounting the Wheel**

## 7. The input methods of date of rim

### 7.1 The power-on state of the machine

After the power-on of the machine, it starts initialization automatically. The initialization will be finished after two seconds. The machine enter natural dynamic (clamp counterweights on the correction plane of the both edged sides of rim) mode automatically, as in Figure 7-1, ready for input date of rim.

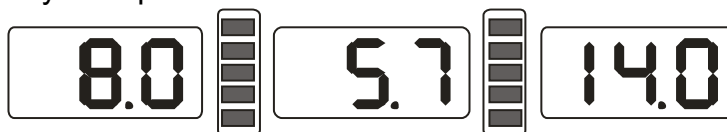

Figure 7-1

### 7.2 Date of wheel input method for normally dynamic balance mode

7.2.1 After the power-on of the machine, it enter the normal balance mode

7.2.2 Input date of rim:

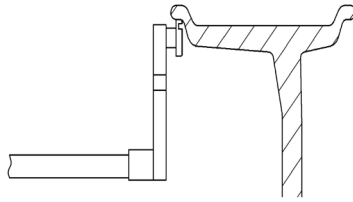

Figure 7-2

Rotate the measure scale, pull the scale head to inside concave on the edge of the rim, etc figure 7-2, first LED all off, then display ect figure 7-3,waiting put back scale.

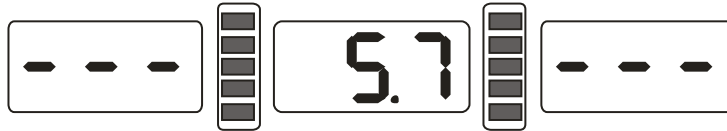

Figure 7-3

When scale back to zero position, LED display value is date of rim.

7.2.3 When measure values with fact value of rim differ, you need self-calibration of scales then measure again or manual input date of rim.

7.2.4 Input date of rim width

Use manual plastic width measure scale, measure the width value of rim then press b+ or b- key input date by manual.

7.3 The date input method of ALU-S mode:

Normally from normal mode change to other mode, do not need input rim date again, just press ALU key change to you select mode in directly is fine, only ALU-S mode have special input method, ALU-S mean is special mode, include below two kind modes (Figure 7-6):



Figure 7-6

ect figure 7-7 or 7-8, Rotate the measure scale, pull the scale head to inside of the rim(FI)(this position is your select to stick balance weight on the inside), measure distance(a) and diameter (dI) of inside of the rim, ect figure 7-9, then continue rotate measure scale, pull the scale head to outside of rim(FE) (this position is your select to stick balance weight on the outside), measure distance(aE) and diameter (dE) of outside of the rim, ect figure 7-10, enter ALU-S mode.

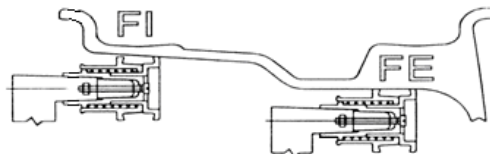

Figure 7-7

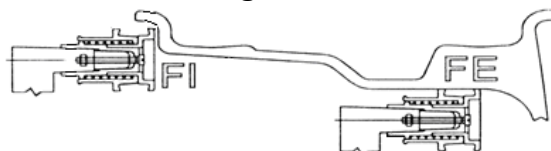

Figure 7-8

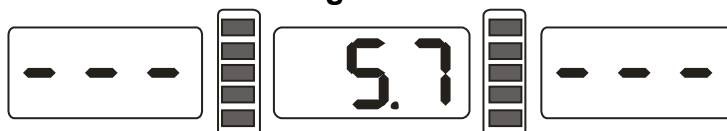

Figure 7-9



**Figure 7-10**

When scale back to zero position, LED will be display aE and dI value. Press a+, a- can be adjust a value; press b+, b- can be adjust aE value; press d+, d- can be adjust dI value; press FINE key LED will display dE value, hold press FINE key and press d+, d- adjust dE value.

**8. Calibration of measure scale**

The measure scale was labeled before ex-factory, but the labeled value may vary because of transportation. Therefore, users can label it themselves before using the balancer.

After the power-on, the initialization is finished. Thus, users can label the measure scale

**8.1 Calibration of rim distance scale**

8.1.1 Press and hold STOP key and press FINE key, ect 8-1, press STOP key or C key to exit.



**Figure 8-1**

8.1.2 Move scale to 0(zero) position, press ALU key, ect 8-2, press STOP key or C key to exit.



**Figure 8-2**

8.1.3 Move scale to 15, press ALU key, ect 8-3, end of self-calibration, put back measure scale.



**Figure 8-3**

**8.2 Calibration of diameter scale**

8.2.1 Installation middle size tyre on principal axis, press and hold STOP key, and press OPT key, ect 8-4, press STOP key to exit;



**Figure 8-4**

8.2.2 Press d+ or d- adjust value to current rim diameter value, press ALU key, ect 8-5;



**Figure 8-5**

8.2.3 Move scale, put scale head on the inside edge of rim ect 7-2, press ALU key, ect 8-3, self-calibration end, put back scale.

### 9. The Self-calibrating of Dynamic Balancer

The self-calibrating of dynamic balancer was finished before ex-factory, but the system parameter may vary because of long-distance transportation or long-term use, which may cause error. Therefore, users can make self-calibrating after a period of time.

- 9.1 After the power-on of the machine, the initialization is finished ect 7-1, install a can clip counterweight and comparatively balanced middle size tyre, follow step 7 input date of rim;
- 9.2 Press D key and C key, ect figure 9-1, (lay down protect hood), press START key, going to next step, press STOP key or C key to exit;



Figure 9-1

- 9.3 After axis stop, ect figure 9-2,(open protect hood)clip a 100 gram counterweight on anywhere of outside of rim, (lay down protect hood)press START key, going to next step, press STOP key or C key to exit;



Figure 9-2

- 9.4 After axis stop, ect 9-3, calibration end. Demount tyre, now balancer ready to work.



Figure 9-3

**NB: when you doing self-calibration, input date of rim must be correct,100 gram counterweight must be correct, otherwise self-calibration result will be wrong, wrong self-calibration will be make balancer measure precision decline.**

### 10. The Balancing Operation of Wheel

#### 10.1 Balance mode change operation

10.1.1 Dynamic and static balance mode switch: press F key.

Dynamic balance mode: clip counterweight on inside and outside edge of rim (balancer tolerant normal balance mode), ect figure 10-1.

ST mode: static balance measure mode, stick counterweight on middle of rim, ect figure 10-2.

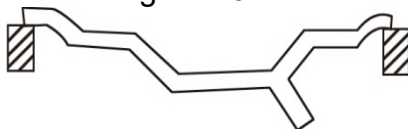
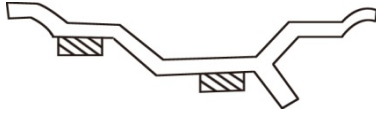

Figure 10-1

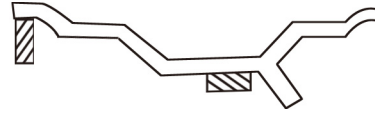

Figure 10-2

10.1.2 ALU balance mode switch key (ALU key), switch CPU system between ALU-1~ALU-S mode.



**Figure 10-3**



**Figure 10-4**

ALU-1 mode: stick counterweight on inside and outside of spoke of rim, ect 10-3.

ALU-2 mode: clip counterweight on inside edge of rim, stick counterweight on outside (inside of spoke), etc figure 10-4.

ALU-S mode: This is a special balance mode (include ALU-1 and ALU-2), for Counterweight split and Hidden-Stick Mode.

Counterweight split and Hidden-Stick Mode:

ALU-S mode, if the outside (inside of spoke) counterweight position between of two spokes, ALU-S mode can split the counterweight for two. The divided counterweight, just place on the back of two spokes near the former counterweight, in order to hide the counterweight. ect figure 10-5.



**Figure 10-5**

## 10.2 Normal balance mode operation process

10.2.1 Follow figure 7.2 input date of rim.

10.2.2 lay down protect hood and press START key, wheel spinning, after stop two side LED display wheel both side imbalance weight, when middle LED display OPT, can choice imbalance optimize;

10.2.3 Slowly spin wheel, when inside counterweight position indicator light (figure 5-1(3)) all on, clip correspond counterweight on 12 o'clock position on inside of rim, ect figure 10-6;

10.2.4 Slowly spin wheel, when outside counterweight position indicator light (figure 5-1(4)) all on, clip correspond counterweight on 12 o'clock position on outside of rim, ect figure 10-7;

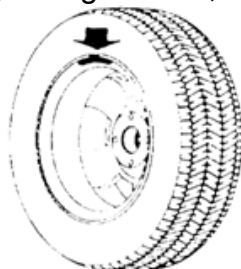

**Figure 10-6**

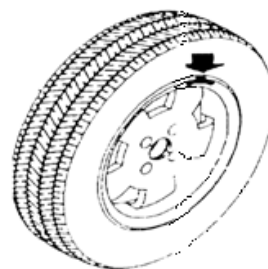

**Figure 10-7**

## 10.3 Static balance (ST) operation process

10.3.1 Move measure scale to middle of rim, and measure the data of rim;

10.3.2 Press F key, switch to static balance (ST) mode.

10.3.3 lay down protect hood and press START key, wheel spinning, after stop middle LED display wheel static imbalance weight, when middle LED display

OPT, can choice imbalance optimize;

- 10.3.4 Slowly spin wheel, when both side counterweight position indicator light (figure 5-1(3), (4)) all on, stick counterweight on 12 o'clock position middle of rim. ect figure 10-8.



**Figure 10-8**

#### 10.4 The operation process of M1 to M2 mode

- 10.4.1 Follow 7.2 input date of rim;  
 10.4.2 Press ALU key, switch to correspond balance mode.  
 10.4.3 lay down protect hood and press START key, wheel spinning, after stop two side LED display wheel both side imbalance weight, when middle LED display OPT, can choice imbalance optimize;  
 10.4.4 Slowly spin wheel, when inside counterweight position indicator light (figure 5-1(3)) all on, follow different mode clip or stick counterweight on 12 o'clock position inside of rim.  
 10.4.5 Slowly spin wheel, when outside counterweight position indicator light (figure 5-1(4)) all on, follow different mode clip or stick counterweight on 12 o'clock position outside of rim.

#### 10.5 ALU-S balance mode operation process

★ Process of manual stickup counterweight

- 10.5.1 Follow figure 7.3 input date of rim.  
 10.5.2 lay down protect hood and press START key, wheel spinning, after stop two side LED display wheel both side imbalance weight, when middle LED display OPT, can choice imbalance optimize;  
 10.5.3 Slowly spin wheel, when inside counterweight position indicator light(figure 5-1(3)) all on, if is follow figure 7-8 input date of rim, next step follow 10.2.3 clip counterweight, if Notec figure 10-9 of left side show, stick counterweight on 12 o'clock position on inside of rim.  
 10.5.4 Slowly spin wheel, when inside counterweight position indicator light(figure 5-1(4)) all on, stick correspond counterweight on 12 o'clock position on outside of rim, ect figure 10-9 right side;

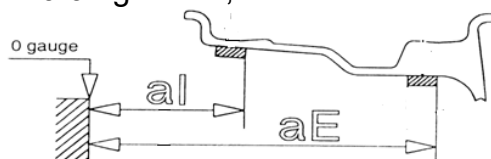
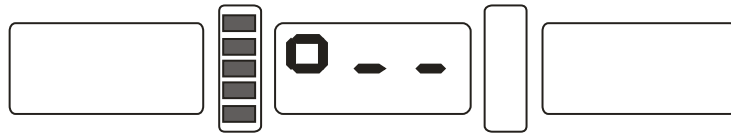

**Figure 10-9**

★ Process of automatic stickup partition Counterweight

- 10.5.5 Follow figure 7.3 input date of rim  
 10.5.6 lay down protect hood and press START key, wheel spinning, after stop two side LED display wheel both side imbalance weight, when middle LED display OPT, can choice imbalance optimize;  
 10.5.7 If is follow figure 7-8 input date of rim, follow 10.2.3 clip counterweight on inside edge of rim. Press STOP key and ALU key, all middle of LED display - - -, follow 10.5.9 stick counterweight on outside of rim.  
 10.5.8 If is follow 7-7 input date of rim, press STOP key and ALU key, all middle of LED display - - -,insert correspond counterweight into the scale head slot, slowly spin wheel, when inside counterweight position indicator light(figure

5-1(9)) all on, draught scale, when inside counterweight position indicator light (figure 5-1(3)) all on, slowly pull out measure scale and middle of LED display as figure 10-10, then turn the scale, stick counterweight on the rim, ect figure 10-12;

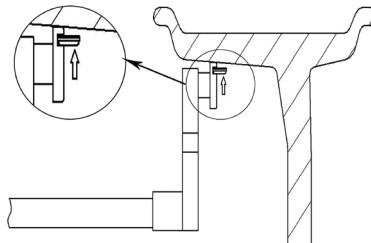

**Figure 10-10**

10.5.9 Insert correspond counterweight into the scale head slot, slowly spin wheel, when outside counterweight position indicator light (figure 5-1(4)) all on, draught scale, when inside counterweight position indicator light (figure 10-11) all on, turn scale, stick counterweight on the rim, ect figure 10-12;



**Figure 10-11**



**Figure 10-12**

**NB: when use scale to stick counterweight automatically, make sure LED must display - - -, if not, do not move scale, press STOP and ALU key, then middle LED display - - -, now you can move scale for automatically sticking counterweight.**

**10.6 The of counterweight hide-stick mode**

Counterweight Hidden-Stick mode is only available in ALU-S mode, this mode can split this position into two parts and make these two new positions hide behind the spoke, so you can achieve this hide purpose. This balance mode only available in ALU-S mode.

In 10.3 operation process, if outside counterweight not hide behind the spoke, but you still want it hide behind the spoke, you can follow below operation:

10.6.1 Press a+ key, back to figure 7-1 interface, press D key and OPT key, display input numbers of spoke (figure 10-13), press b+ or b- key input spoke numbers, press D key and OPT key to save and return, slowly turn the wheel, turn the near by imbalance position of spoke on the top (12 o'clock), press D and OPT key to enter hide stick mode, and then press D and OPT key to exit;

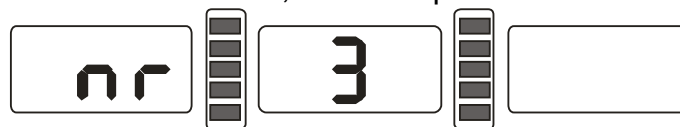

**Figure 10-13**

★ Split manual stick operation

10.6.2 Stick inside operation same 10.5.3;

10.6.3 Slowly spin wheel, when outside counterweight position indicator light (figure 5-1(4)) all on, stick counterweight on 12 o'clock position outside of rim, ect figure 10-9 right side;

10.6.4 Slowly spin wheel again, when outside counterweight position indicator light (figure 5-1(4)) all on, find second position, stick counterweight on 12 o'clock position outside of rim, ect figure 10-9 right side;

★ Split automatic stick operation

10.6.5 When stick inside, operation same 10.3.7 and 10.3.8

10.6.6 Slowly spin wheel, when outside counterweight position indicator light (figure 5-1(4)) all on, find first position, draught scale, when outside counterweight position indicator light (figure 10-11) all on, turn scale, stick counterweight on rim (ect figure 10-12);

10.6.7 Slowly spin wheel, when outside counterweight position indicator light (figure 5-1(4)) all on, find second position, draught scale, when outside counterweight position indicator light (figure 10-11) all on, turn scale, stick counterweight on rim (ect figure 10-12).

**NB: when use scale to stick counterweight automatically, make sure LED must display - - -, if not, do not move scale, press STOP and ALU key, then middle LED display - - -, now you can move scale for automatically sticking counterweight.**

## 10.7 Recalculation

Before wheel balance testing, sometimes may forget input current date of rim, you can after wheel balance testing input date of rim reintroduce, at this time do not need press START key, just press recalculation key (C) system will follow new date of rim calculation imbalance measure. Even interface currently display imbalance value, press C key, can be check currently input date of rim.

## 11. Imbalance optimize

If wheel imbalance value over 30 gram, system will be display "OPT", clue on process imbalance optimize.

Imbalance optimize have two operation method:

11.1 Already display balance value

If already finish balance testing, when you need process imbalance optimize, press OPT key, display ect figure 11-1;



Figure 11-1

Use chalk mark a reference point on the flange plane and rim and tyre, use tyre changer exchange rim and tyre 180°; Reinstall wheel on the balancer and make sure mark of reference point between the flange plane and rim must be on the same position. press START key, display ect figure 11-2;

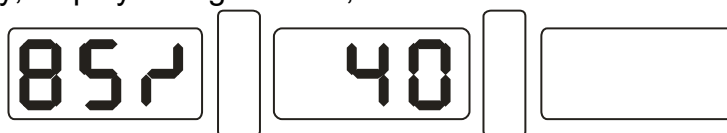

Figure 11-2

ect Figure 11-2, left LED display percent of optimize, if before optimize static value is 40 gram, optimized is 85%, so after optimize static value only 6 gram remain ( $15\% \times 40\text{gram} = 6\text{gram}$ );

Slowly spin wheel by hand, when both side two of position indicator light flashing (figure 11-3), use mark pen make a mark on the tyre;



**Figure 11-3**

Slowly spin wheel by hand again, when both side one of middle position indicator light flashing (figure 11-4), use mark pen make a mark on the rim;



**Figure 11-4**

Remove the wheel from balancer, use tyre changer remove tyre from rim, make tyre and rim marks together, use tyre changer fit tyre on the rim, optimize complete.

11.2 Before testing of power on, also process imbalance optimize directly

Turn on the power, installation wheel, press OPT key, left side display OPT, press START key, display ect figure 11-1, then follow 11.1 step to operation. Press STOP key to stop operation.

**12. Gram-Oz conversion operation**

This operation for counterweight maund conversion (gram-Oz).

12.1 Press STOP key and a+ key or a-, display ect figure 12-1, denotation currently maund is gram.

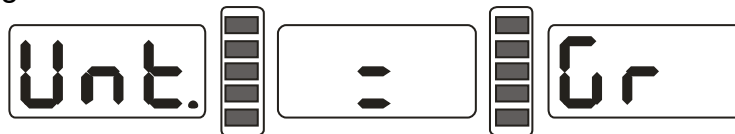

**Figure 12-1**

12.2 Press b+ or b- key, display ect figure 12-2, denotation currently maund is Oz;

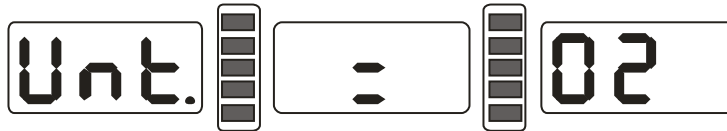

**Figure 12-2**

12.3 Press b+ or b- key for switch maund between gram and Oz;

12.4 Press a+ key to save setup and exit.

**13. INCH and MM conversion operation**

This operation for input dimension B value and D value conversion (INCH-MM).

Press INCH/MM key, long measure of LED 6 display value B and LED 7 display value D can be change between INCH/MM. if in the LED display window right underside have a radix point mean currently long measure is INCH, if not, long measure is MM.

**14. Protect hood function and protect setting**

This function can be setting closing protect hood motor start or lay down protect hood properly, then press START key to start motor.

Press STOP key and C key, ect figure 14-1, right display currently state, when display ON, denotation function on, when display OFF, denotation function off.

Press b+ or b- key for switch protect hood function between "ON" and "OFF";

Press a+ key to save currently settings and exit.

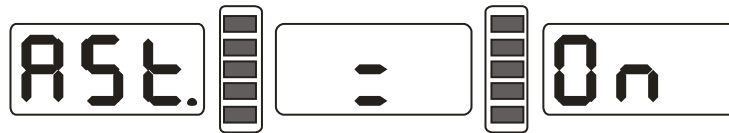

Figure 14-1

## 15. Other function settings

### 15.1 Minimum value display settings

After select minimum value display ,even wheel imbalance value less than setting value, result will be display 0(zero),press FINE key, will be display fact imbalance value. Press STOP and D key, ect figure 15-1,denotation imbalance value less than 5 gram, display is 0g(zero gram),press b+ or b- key setting minimum value, are 5 and 10 and 15gram three distinctions. Press a+ key to save settings and enter next step;



Figure 15-1

### 15.2 Key-tone clue on function settings

This function can turn on or turn off key-tone, even turn on this function, every time press key, system will be emit a "di" of tone, even turn off this function, press key not tone. From 15.1 press a+ enter settings, ect figure 15-2,right side display ON denotation function on, display OFF denotation function off. Press b+ or b- key, function will be switch between "ON" and "OFF". Press a+ key to save settings and enter next step;



Figure 15-2

### 15.3 Display monitor brightness settings

This function will follow use environment and user need, setting display brightness. From 15.2 press a+ enter settings, ect figure 15-3,right side display brightness grade, altogether is 8 levels, level 1 is darkest, level 8 is brightest, default is level 4.press b+ or b- key, function will be switch brightness levels. Press a+ key to save settings and enter next step;



Figure 15-3

## 16. Machine self test function

This function will be check all kinds input signal whether right working and provide gist for trouble analyses.

### 16.1 LED and indicator light check

Press D key, whole LED and indicator light all turn on, this function can be check LED or indicator light whether appear damage, press C key to exit, after about 5 seconds display ect figure 16-1,enter position sensor check. Press C key to exit.



Figure 16-1

### 16.2 Position sensor signal check

This function can be check position sensor and principal axis and main board circuit whether damage.

Slowly turn principal axis, right side LED display number appear change, clockwise turn, and value increase. Anticlockwise turn, value minish, correct value change is between 0 to 63.press ALU key, enter distance sensor check. Press C key to exit.

### 16.3 Distance sensor signal check

This function can be check distance sensor and main board signal circuit whether damage.

From 16.2 press ALU key enter, ect figure 16-2, move measure scale, value will be change, value follow move more increase. Press ALU key, enter diameter sensor signal check. Press C key exit.



Figure 16-2

### 16.4 Diameter sensor signal check

This function can be check diameter sensor and main board signal circuit whether damage.

From 16.3 press ALU key enter, ect figure 16-3, turn measure scale, value will be change, anticlockwise turn, value increase, clockwise press turn, value minish. Press ALU key, enter press sensor signal check. Press C key exit.



Figure 16-3

### 16.5 Press sensor signal check

This function can be check press sensor and main board signal circuit and power supply whether damage.

From 16.4 press ALU key enter, ect figure 16-4, gently press principal axis, right and left LED display value will be change, press ALU key to enter press sensor signal check. Press C key exit.



Figure 16-4

## 17. Safety Protections and Trouble Shooting

### 17.1 Safety protection

17.1.1 Under the circumstance of operation, if the machine does not operate normally, press STOP key, the rotating wheel will stop immediately.

17.1.2 If hood is not laid down, press START key, the wheel will not rotate.

17.1.3 Under the circumstance of operation, if hood open, the rotating wheel will stop immediately.

### 17.2 Trouble shooting

17.2.1 After press START key, principal-axis not spinning, LED display Err-1.check motor, computer board and cable connections;

- 17.2.2 After press START key, principal axis rotate, LED display Err-1. check position sensor, computer board and cable connections;
- 17.2.3 If balance test already end, balancer still rotates for a long time, does not brake, check brake resistance, power supply board, computer board and cable connections;
- 17.2.4 If turn on the power LED display ect figure 17-1, need measure scale self-calibration or adjust a-value sensor or replacement new sensor;

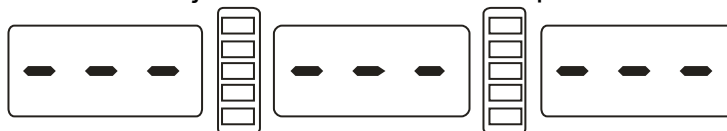

**Figure 17-1**

- 17.2.5 Automatic measure rim, advert display date whether difference with trim size of rim, if difference, need measure scale self-calibration;
- 17.2.6 If turn on the power have not display, check power switch indicator light whether working, if not, check power supply first, then check power supply board and computer board and cable connections;
- 17.2.7 Precision not nicety, commonly hurtful not from balancer, may wheel installation wrong or counterweight heft not nicety or 100 gram counterweight for balance self-calibration not nicety, must be always keep manufactory's 100 gram counterweight safety for self-calibration only.
- 17.2.8 Date not astaticism, repeat difference, commonly hurtful not from balancer, may wheel installation wrong or floor not messiness not level off, may as well fixation balancer by bolt. Sometimes not connection earth wire may appear this phenomenon.
- 17.2.9 If add weights many times, the tire still can not be balanced, it is possible the operator did find the correct unbalanced position and weights were not added on the correct position. Follow the instructions to do the self-calibration once. If still can not solve the problem, check it as following ways: 1)put down the protective cover, start the machine to test the tire; 2)turn the tire slowly by hand, to find the lateral unbalanced position; 3)add a 100g weight on the lateral position of rim(12 o' clock position); start the machine to test the tire, turn the tire by hand slowly, to find the lateral unbalanced position; check if the position of 100g weight is on the position of 6 o' clock(the bottom position); If no, it means the parameters of the machine has changed, please contact the dealer or manufacturer to solve it.

**Hint: check precision right method:**

**Input right date of wheel(a. b. d value),consult instruction do a self-calibration, press START process balance operation, note down date of first time, clip 100 gram counterweight on the outside edge of wheel(when outside indicator light all on is top zenith position),press START key again process balance operation, this date of outside display addition date of first time, should amount  $100\pm 2$ ,manually slowly turn the wheel, when light of outside all on, check 100 gram counterweight whether at 6 o'clock position, if not amount 100 gram or 100 gram counterweight not at 6 o'clock position, indicate balancer precision have problem, if amount is 100 gram, follow same method check inside, check inside whether amount is 100 gram and at 6 o'clock.**

## 18. Maintenance

### 18.1 The daily maintenance of non- professionals

Before the maintenance, please switch off the power-supply.

18.1.1 Adjust the tension of the belt.

18.1.1.1 Dismantle the hood.

18.1.1.2 Unlash the screw of the motor, move the motor till the belt's tension is proper, and emphatically press the belt downwards about 4mm.

18.1.1.3 Tighten the screw of the motor and cover the hood.

18.1.2 Check whether the wire of electricity part connects reliably.

18.1.3 Check whether the pressed screw of the main axis is loose.

18.1.3.1 Locking nut can not fix wheel tighten on main-axis

18.1.3.2 Use hexagonal wrench to tighten the pressed screw of the main-axis.

### 18.2 The maintenance of professionals

The maintenance of professionals can only be carried out by the professionals from the factory.

18.2.1 If the imbalance value of tested wheel has obvious errors and does not improve after self-calibrating, this proves the parameter in the machine has altered, so the user should ask for professionals.

18.2.2 The replacing and adjustment of pressure sensor should be operated according to the following methods, and the operation should be carried out by professionals.

The steps are as follows:

1. Unlash the No.1, 2,3,4,5 nuts.

2. Dismantle the sensor and nut.

3. Replace No.6, 7 the sensor organ.

4. Install the sensor and the nut according to the Figure 18-1. (Pay attention to the sensor's direction.)

5. Tighten No.1 nut emphatically.

6. Tighten the No.2 nut to make the main axis and the flank of cabinet, and then emphatically tighten the No.3 nut.

7. Tighten the No.4 nut (not too emphatically), then tighten No.5 nut.

18.2.3 The replacing of circuit board and the organ on it should be carried out by professionals.

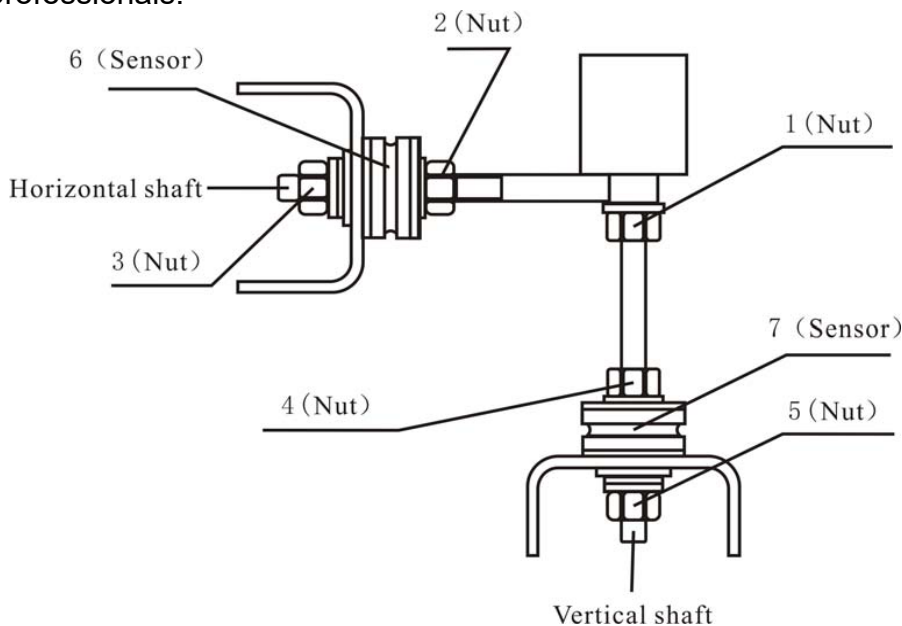

Figure 18-1

## 19. Trouble-error code list

When balancer display hint of error, can follow consult below list to remove the trouble:

Code	meanings	cause	remedy
Err 1	principal axis not spin or have not spin signal	1.motor fault 2.position sensor fault 3.power supply board fault  4.computer board fault 5.connection-peg untouched	1.change motor 2.change position sensor 3.change power supply board 4.change computer board 5.check cable connections
Err 2	The rotation is lower than 60r/min	1. position sensor fault 2. wheel not impacting or weight too light 3. motor fault 4. driving belt too loose or too tighten 5. computer board fault	1. change position sensor 2.repeat impacting wheel  3. change motor 4.adjust driving belt elasticity 5. change computer board
Err 3	Miscalculation	too high imbalance	Repeat the self-calibration change computer board
Err 4	principal axis Wrong rotation direction	1. position sensor fault 2. computer board fault	1. change position sensor 2. change computer board
Err 5	Protection hood not lay down	1.when press START key, Protection hood not lay down 2. jiggle switch fault 3. computer board fault	1.follow right method operation 2.change jiggle switch 3. change computer board
Err 6	Sensor signal transact circuit not working	1. power supply board fault  2. computer board fault	1. change power supply board 2. change computer board
Err 7	Lose date of interior	1. Incorrect self-calibration  2. computer board fault	1. Repeat the self-calibration 2. change computer board
Err 8	Self-calibration memory fault	1. not put 100 gram on the rim when self-calibration 2. power supply board fault  3. computer board fault 4. press sensor fault 5. connection-peg untouched	1.follow right method repeat self-calibration 2. change power supply board 3. change computer board 4.change press sensor 5.check cable connection

## 20. Power supply layout diagram

### 20.1 220 V Connection

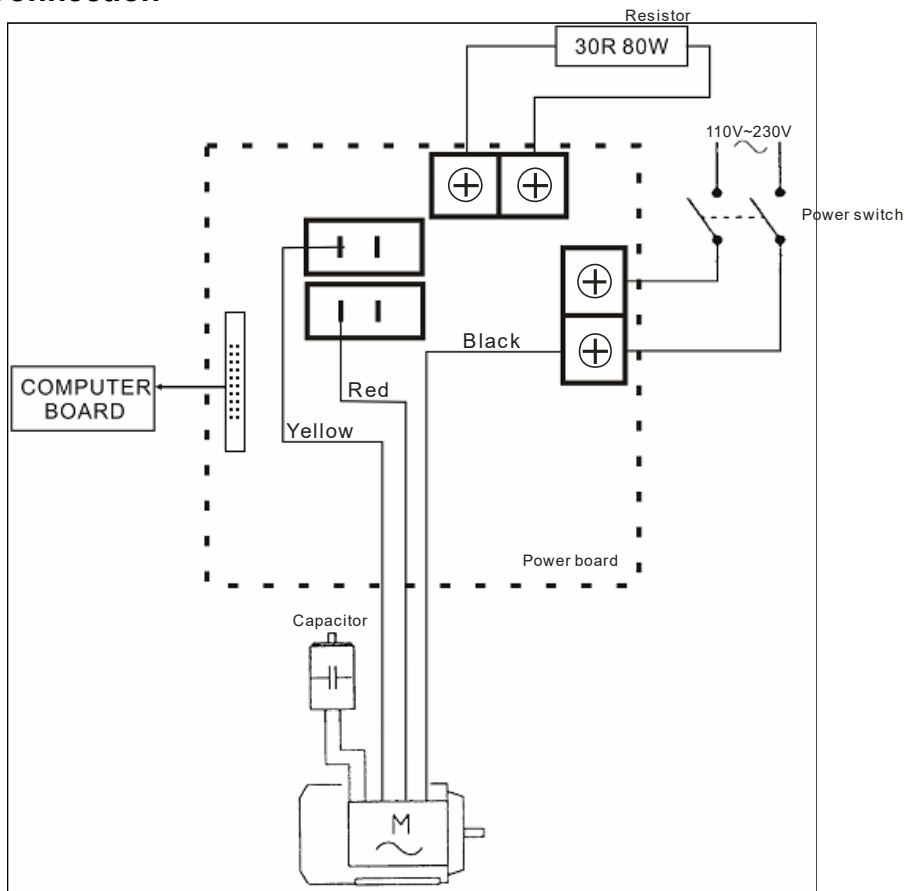

### 20.2 380 V Connection

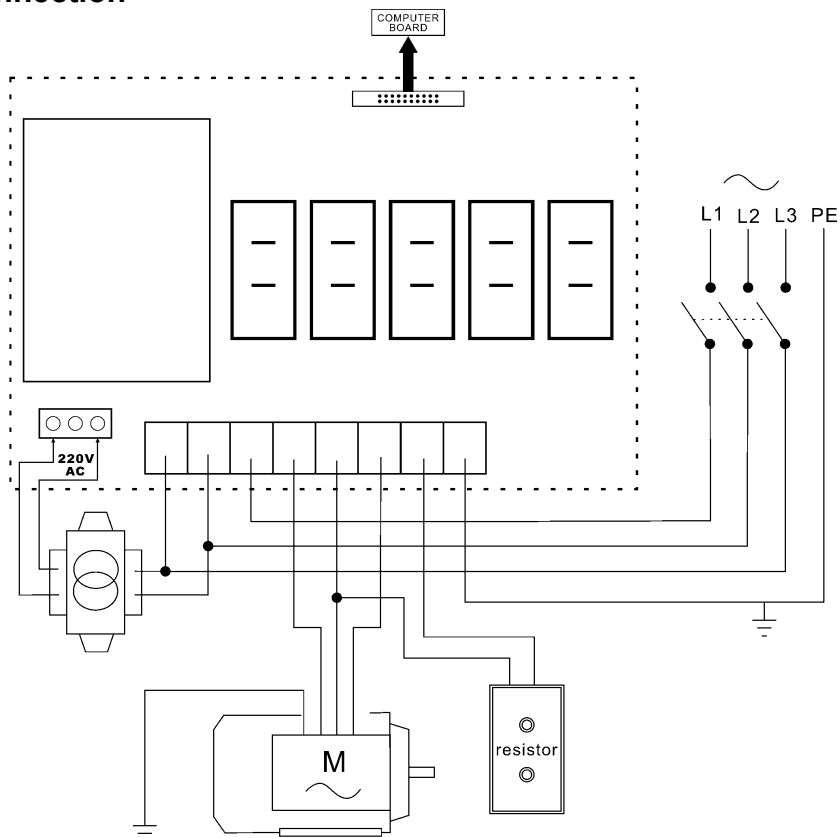

21. Exploded drawings

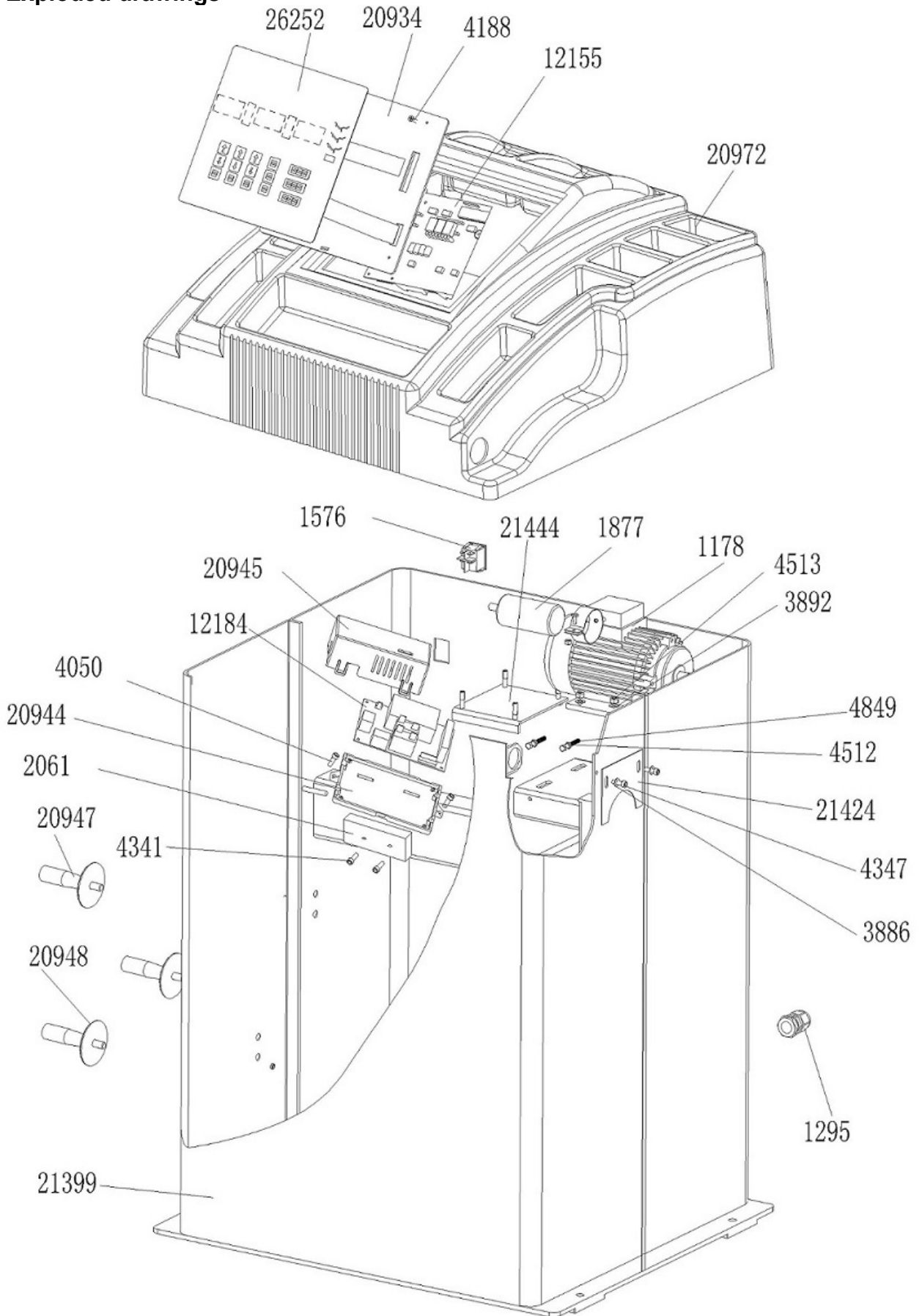

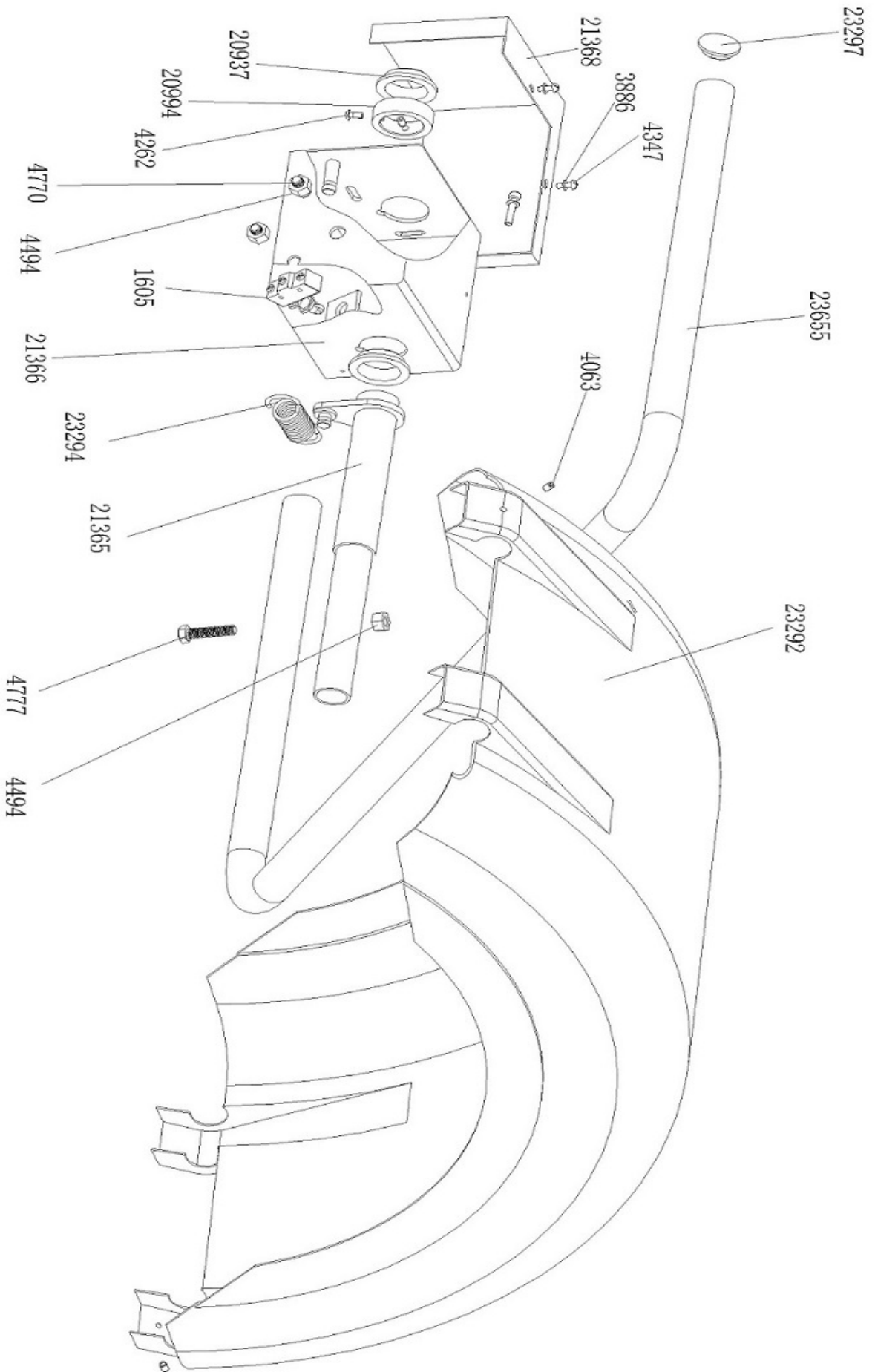

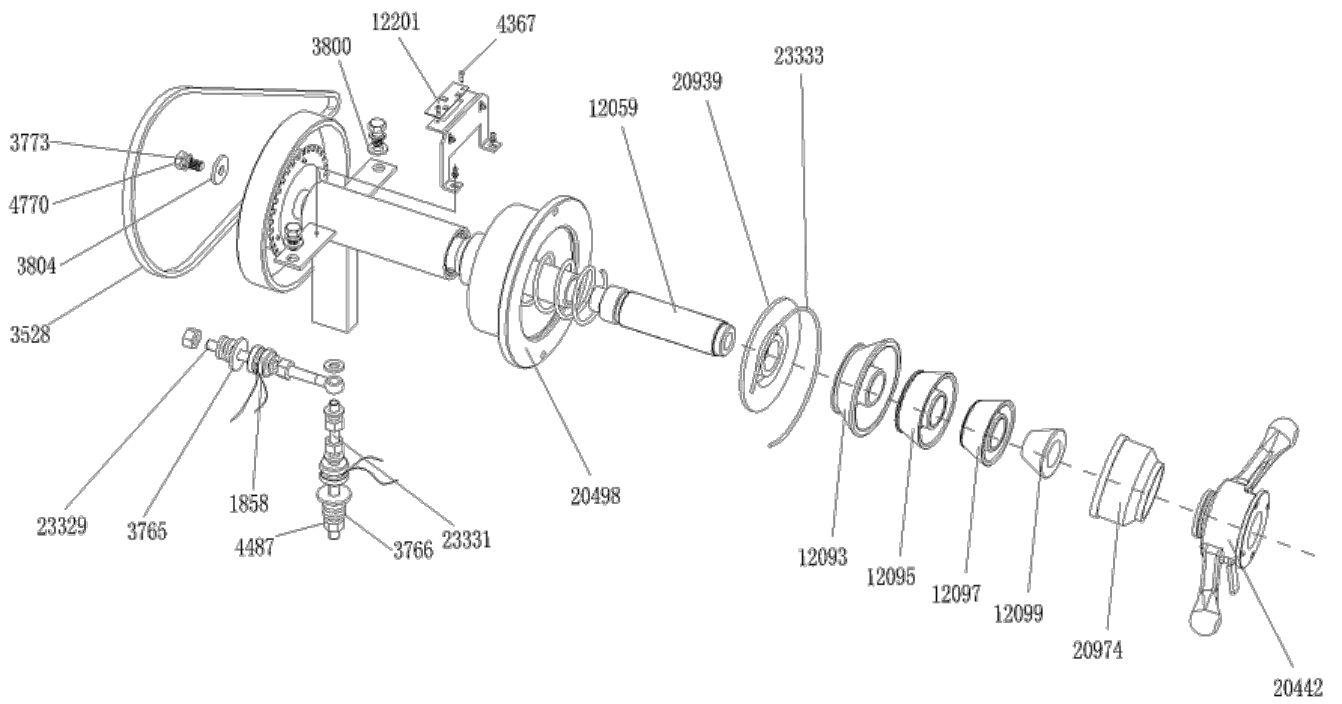
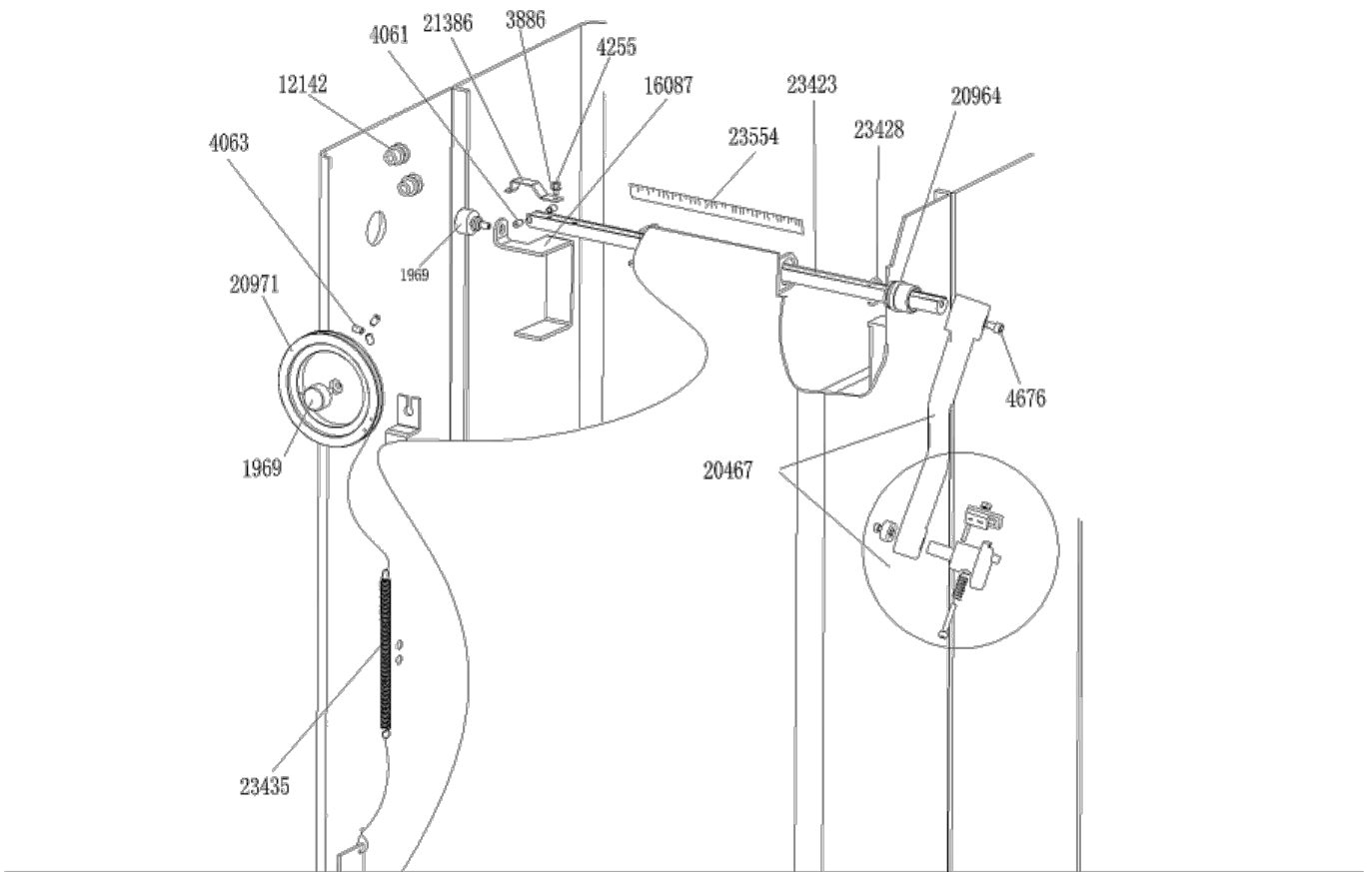

## 22. Spare parts list

No.	Code	Description	Qt.	No.	Code	Description	Qt.
21399	JZ08002021399	Main Body	1	21365	JZ08002021365	Shaft	1
20944	JZ07002020944	Electric Board Suppor	1	4777	FJ04009004777	Screw	1
4050	FJ04006004050	Screw	2	4494	FJ04008004494	Nut	1
12184	JZ02008012184	Power Board	1	23292	JZ09002023292	Hood	1
20945	JZ07002020945	Box	1	4063	FJ04006004063	Screw	3
2061	DD04010002061	Resistor	1				
4341	FJ04006004341	Screw	2	4676	FJ04009004676	Screw	1
1576	DD03009001576	Power Switch	1	20467	JZ06002020467	Handle bar	1
21444	JZ03002021444	motor adjust board	1	20964	JZ07002020964	Plastic bush	2
1877	DD04009001877	Capacitor	1	23428	JZ09002023428	Seeger ring	2
1178	DD01001001178	Complete Motor	1	23423	JZ09002023423	Rim distance gauge	1
3892	FJ04002003892	Washer	4	16087	JZ03002016087	Heavy	1
4513	FJ04008004513	Nut	4	4255	FJ04006004255	Screw	1
4849	FJ04009004849	Screw	2	3886	FJ04002003886	Washer	1
4512	FJ04008004512	Nut	2	21386	JZ03002021386	Caliper Hook	1
21424	JZ08002021424	Plate	1	4061	FJ04006004061	Screw	2
4347	FJ04006004347	Screw	2	12142	JZ02008012142	Pulley	2
3886	FJ04002003886	Washer	2	20971	JZ07002020971	Bobbin winder pulley	1
1295	DD02001001295	Cable Circlip	1	4063	FJ04006004063	Screw	3
20947	JZ07002020947	Tools Hang	3	1969	DD04010001969	Gauge sensor	2
20948	JZ07002020948	ABS Washer	3	23435	JZ09002023435	Spring	1
				23554	JZ09002023554	Graduated strip	1
20972	JZ07002020972	Head with tools-tray	1				
20934	JZ07002020934	Key board support	1	3528	FJ02003003528	Belt	1
4188	FJ04006004188	Screw	4	3804	FJ04002003804	Washer	1
12155	JZ02008012155	Computer board	1	4770	FJ04009004770	Screw	3
26252	JZ10001026252	Key board	1	3773	FJ04002003773	Washer	3
				3800	FJ04002003800	Washer	6
23655	JZ09002023655	Shaft	1	12201	JZ02008012201	Position Pick-up Board	1
4347	FJ04006004347	Screw	3	4367	FJ04006004367	Screw	4
3886	FJ04002003886	Washer	3	12059	JZ02008012059	Thread	1
21368	JZ08002021368	Cover	1	20939	JZ07002020939	Plastic Lid	1
20937	JZ07002020937	Sheath	2	23333	JZ09002023333	Spring	1
20994	JZ07002020994	Shaft sheath	1	12093	JZ02008012093	1# CONE	1
4262	FJ04006004262	Screw	1	12095	JZ02008012095	2# CONE	1
4770	FJ04009004770	Screw	3	12097	JZ02008012097	3# CONE	1
4494	FJ04008004494	Nut	3	12099	JZ02008012099	4# CONE	1
1605	DD03009001605	Mirco switch	1	20974	JZ07002020974	Plastic lid	1
21366	JZ08002021366	Shaft box	1	20442	JZ06002020442	Complete quick release nut Tr36	1
23297	JZ09002023297	Shaft Plug	1	20498	JZ06002020498	Complete Shaft	1
23294	JZ09002023294	Spring	1	23331	JZ09002023331	Screw	1



**Accessories list**

**Specification options** 1: 36  2: 40

CODE	ITEM	QTY	PHOTO
1:JZ02008012093	1# CONE	1	
2:JZ02008012094			
1:JZ02008012095	2# CONE	1	
2:JZ02008012096			
1:JZ02008012097	3# CONE	1	
2:JZ02008012098			
1:JZ02008012099	4# CONE	1	
2:JZ02008012100			
1:JZ06002020442	COMPLETE QUICK RELEASE NUT	1	
2:JZ06002020443			
1:JZ02008012059	THREADED SHAFT	1	
2:JZ02008012060			
IY09005029246	MANUAL	1	
JZ03002016059	WRENCH	1	
HG02001028224	HEX WRENCH	1	
HG02001028227	HEX WRENCH	1	
JZ09002023492	STANDARD WEIGHTS 100G	1	
JZ07002020959	CALIPER	1	
JZ09002023563	PLIER	1	
JZ07002020974	PLASTIC LID	1	
JZ09002023408	RUBBER BUFFER	1	

For one item with two codes, please select as per Specification Options, or select by measuring real object.

# Attach figure 1

# System circuit diagram

