

71.MCL.500

ELECTRIC HYDRAULIC MOTORCYCLE LIFT INSTRUCTION & MAINTENANCE MANUAL



Jimmy Industrial Pty Ltd
5 Cord St
Dudley Park, 5008
Ph: (08) 8269 9700
W: www.jimmytools.com.au
E: sales@jimmytools.com.au



Read this entire manual carefully and completely before installation or operation of the lift

SCISSOR LIFT INSTRUCTION MANUAL

INDEX	PAGE
1. Packing, transport and storage.....	- 3 -
1.1 Packing:.....	- 3 -
1.2 Transport:	- 3 -
1.3 Storage:	- 4 -
2. Manual introduction	- 4 -
3. Description of the machine.....	- 5 -
3.1 Machine Application	- 5 -
3.2 Structure Features.....	- 5 -
3.3 Safety lock structure.....	- 5 -
3.4 Equipment	- 5 -
3.5 Frame.....	- 5 -
3.6 Power unit	- 6 -
4. Specifications	- 6 -
4.1 Main technical parameter	- 6 -
4.2 External dimension drawing.....	- 7 -
5. Operation.....	- 8 -
6. Maintenance and care.....	- 9 -
7. Circuit diagram.....	- 10 -
8. air loop diagram	- 11 -
9. Explosion drawing.....	- 12 -
10. Accessories Packing List.....	- 19 -

1. Packing, transport and storage



All packing, lifting, handling, transport and unpacking operations are to be performed exclusively by expert personnel.

1.1 Packing:

Packing List

NO.	Name	Accessory name and quantity
1	Frame	Frame 1 piece
2	Accessory box	Tyre clamp spare part 1 piece

Table 1

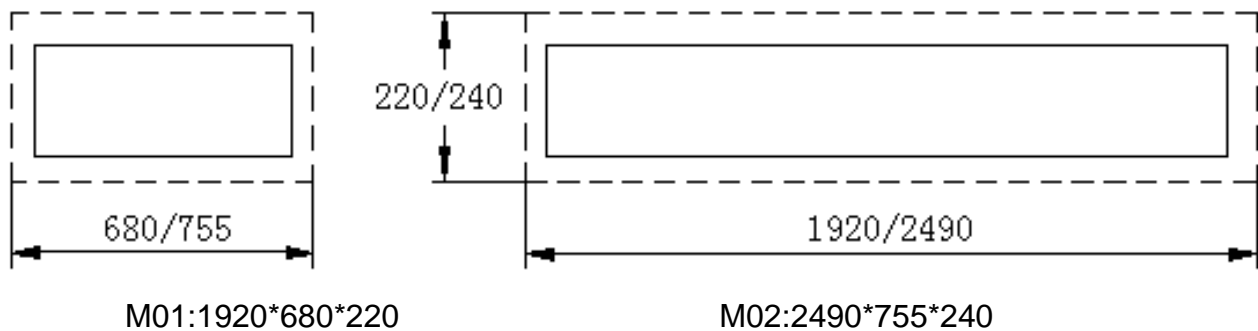

Picture 1(Packing dimension picture)

1.2 Transport:



Packing can be lifted or moved by lift trucks, cranes or bridge cranes. In case of slinging, a second person must always take care of the load, in order to avoid dangerous oscillations.

During loading and unloading operation, goods must be handled by motorcycle or ships.

At the arrival of the goods, verify that all items specified in the delivery notes are included. In case of missing parts possible defects or damage may due to transport operations.

If finding missing parts, possible defects or damage due to transport, one should examine damaged cartons according to <<Accessories Packing List.>> to verify the condition of damaged goods and missing parts, also the person in charge or the carrier must be immediately informed.



The machine is heavy goods! Don't take manpower load and unloading and transporting way into consideration, the safety of working is important.

Furthermore, during loading and unloading operation goods must be handled as shown in the picture. (Picture 2)

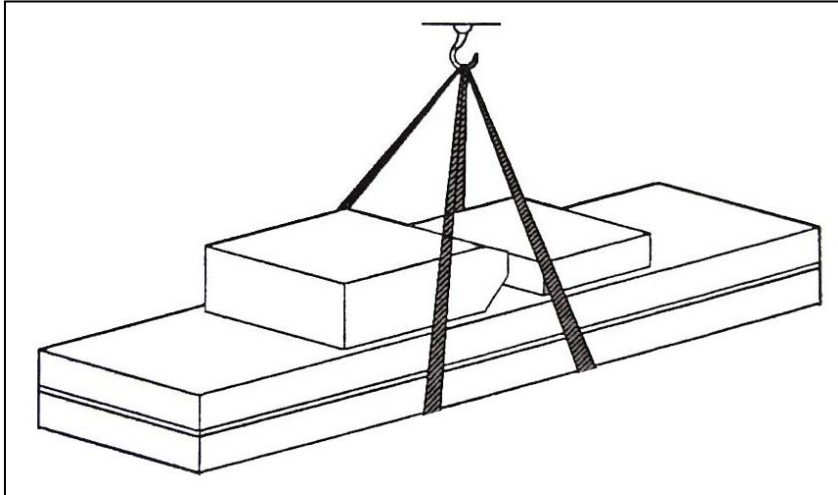

Picture 2 (Goods-lifted)

1.3 Storage:

- The machine equipment should be stocked in the warehouse, if stocked outside should do the disposal well of waterproof.
- Use box truck in the process of transport, use container storage when shipping.
- The control box should be placed perpendicularly during the transport; and prevent other goods from extrusion.
- The temperature for machine storage : -25°C-- 55°C

2. Manual introduction



This manual has been prepared for workshop personnel expert in the use of the lift operator and technicians responsible for routine maintenance fitter.

Workers should read the <<Instruction & Maintenance Manual>> carefully before carrying out any operation with the lift. This manual contains important information regarding:

- The personal safety of operators and maintenance workers.
- Lift safety.
- The safety of lifted motorcycle.



Several tips should be done by the operator as follow:

- 1.Well conserving the manual. Manufacturer owns the right to make little change for the manual owing to the improvement of technology.
- 2.Good disposal the used oil.
- 3.The machine must be demolished by authorized technicians, just like for assembling

3. Description of the machine

3.1 Machine Application



Electric hydraulic motorcycle lift can lift all kinds of motorcycle whose weight is less than 300kg/500kg, It can be used in motorcycle service shop for tyre service and motorcycle maintenance.

3.2 Structure Features

- Convenient and portable structure, for tyre and wheelbase maintenance.
- Lifting height 1200mm, suitable for all kinds of motorcycle
- Double safety devices, hydraulic locking and mechanical safety clamp, ensure its stability during landing
- Two pedal switches to control the pneumatic front tyre clamp.

3.3 Safety lock structure

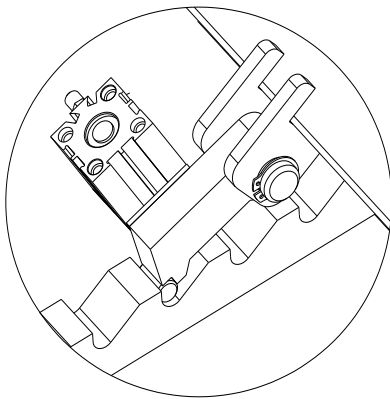

Picture 3

3.4 Equipment

- Machine basement (The position and space of equipment installation)
- Machine frame (The main structure of lift and insurance institution)
- Power unit (Machine-controlled part)

3.5 Frame

Make of base plate, platform and hydraulic cylinder.

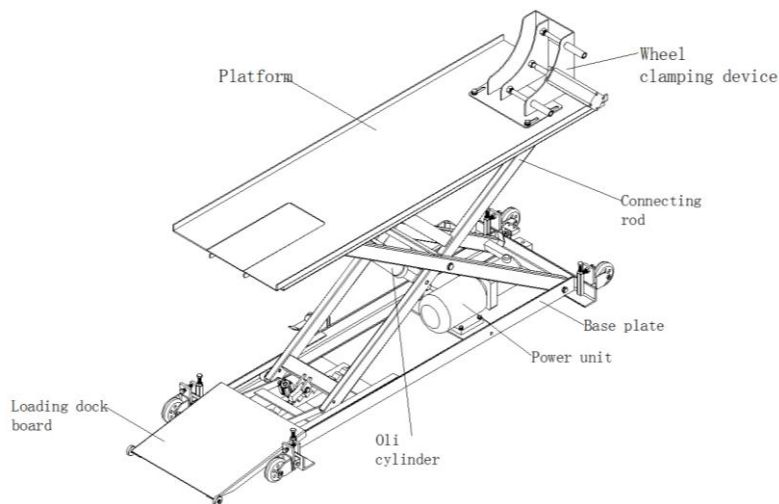

Picture 4

3.6 Power unit

It is made up of hydraulic pump, motor, oil hose and electric control box

Function of each valve on the power unit	
Name	Function
Gear pump	Extract hydraulic oil and provide high pressure.
Valve block	Connect the motor and the gear pump.
Motor	Provide power for the gear pump.
Overflow valve	Adjust oil pressure.
Pressure-compensated valve	Control the speed of falling.
Lowering solenoid valve	Control flow of the hydraulic oil.
One-way valve	Control the one-way flow of hydraulic oil.

4. Specifications

4.1 Main technical parameter

Machine type	M01	M02
Drive	Power unit	
Lifting capacity	300kg	500kg
Machine lift height	1200mm	
Platform initial height	180mm	200mm
Platform length	1800mm	2480mm
Platform width	570mm	720mm
Lifting time	≤20s	≤30s
Descent time	≤20s	≤30s
Whole machine length	2360mm	3170mm
Whole machine width	670mm	820mm
Power supply	2/PE~240V, 50Hz, 10A	
Whole machine power	0.75kw	
Hydraulic oil	1.5L corresponds to wearable hydraulic oil	
air pressure		
Working temperature	5-40℃	
Working humidity	30-95%	
Noisy	< 70db	
Storage temperature	-25℃~55℃	

Table 2

4.2 External dimension drawing

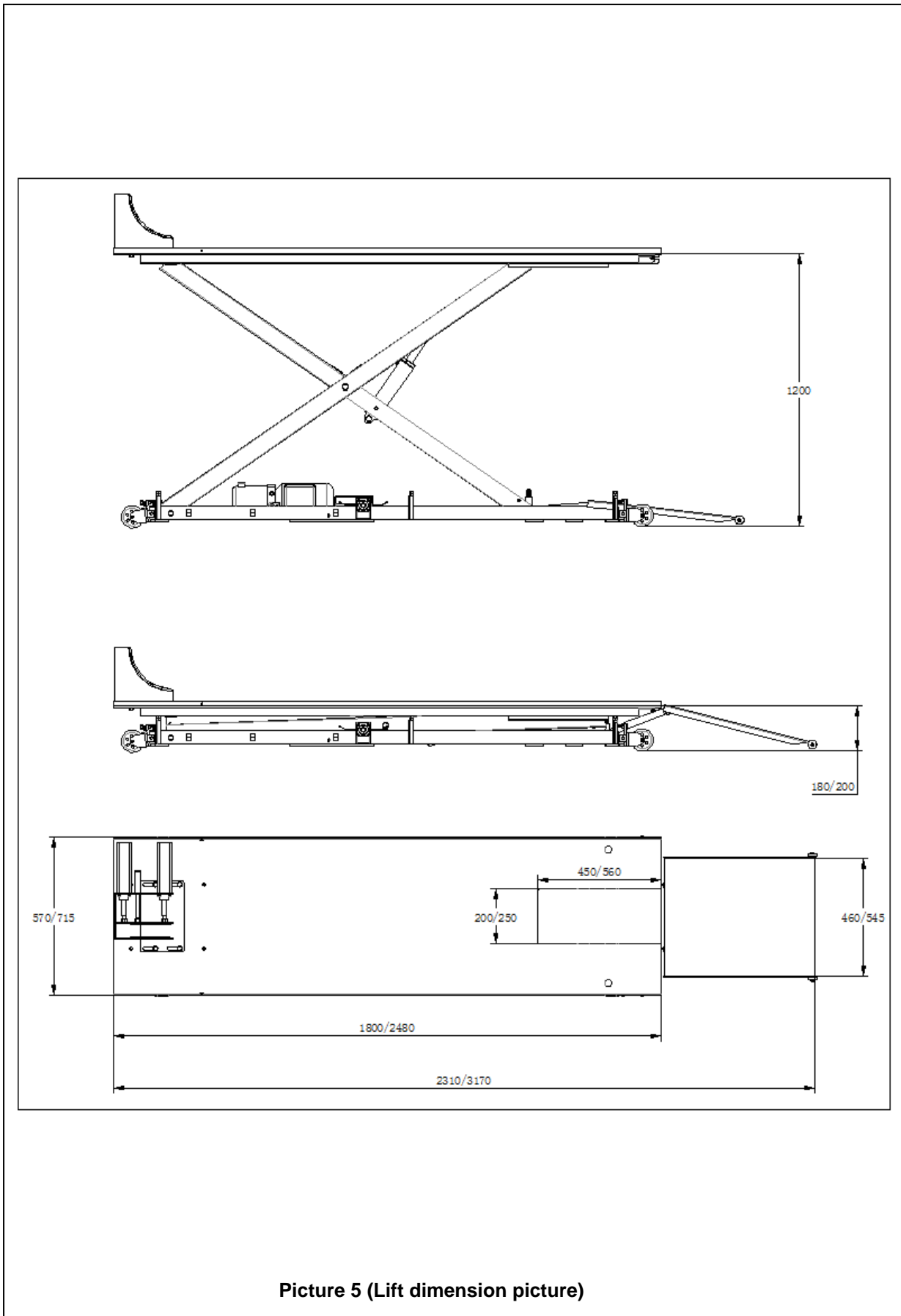

Picture 5 (Lift dimension picture)

5. Operation

The wire control handle (figure 1).

- Rotate the scram button clockwise and the machine is switch on the power supply (notice: Can't reverse direction),
- press up button, oil pump working, and the platform lift
- press down button, platform lower.
- press scram button, cut off all the operation,

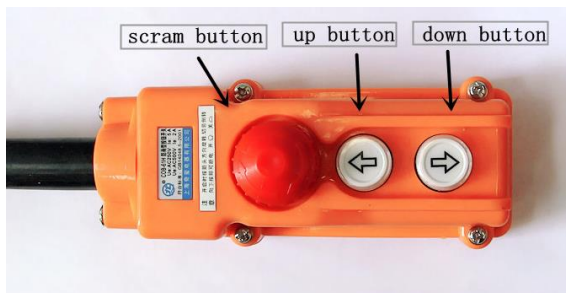

Picture 6



Picture 7

When lifting up to the top, the machine will cut off the power supply automatically (picture 8). When falling, step the DOWN pedal switch to unlock for falling.

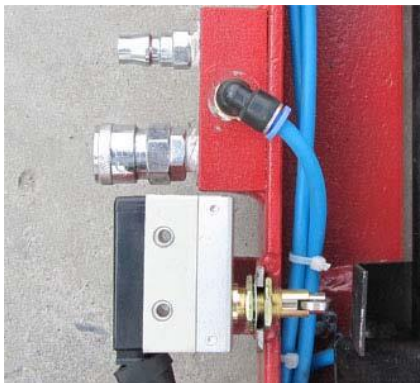

Picture 8



Picture 9

There is a door at the end of the platform. Pull the door back to let it down (picture 9). When the front tyre is clamped, pay attention to the position of the disc (picture 10). Before removing the machine, use a spanner to draw back the mobile wheels for movement (picture 11)

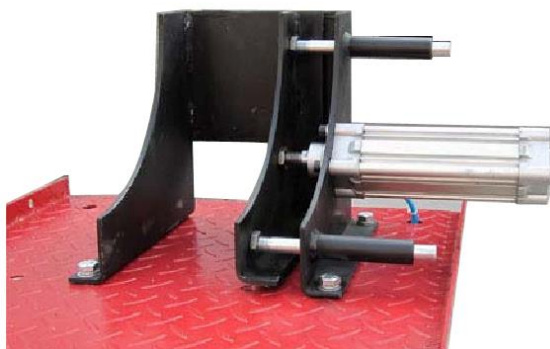

Picture 10



Picture 11



Caution: The machine can be used only when the four mobile wheels are put away and the base touches the flat and hard ground completely

6. Maintenance and care



Skilled personnel only is allowed to perform the operations

Daily checking items

The user must perform daily check. Daily check of safety system is very important – the discovery of device failure before action could save your time and prevent you from great loss, injury or casualty.

- Always wipe clean, keep the machine clean.
- Clear barriers and ground oil, keep the working condition clean.
- Check the integrity of each safety devices, ensure the motion is flexible and reliable.
- Check the reliability of limit switch motion.
- Check whether oil leakage of the machine exist.

Weekly checking items

- All bearings and hinges on this machine must be lubricated once a week by using an oiler
- Check the working conditions of safety parts.
- Check the amount of oil left in the oil tank. Oil is enough if the carriage can be raised to highest position. Otherwise, oil is insufficient.

Monthly checking items

- The safety gear and other movable parts must be lubricated one month.
- Check the abrasion and leakage of oil hose.

Yearly checking items

- The hydraulic oil must be replaced one time each year. The oil level should always be kept at upper limit position.
- Check abrasion and damage of all the active parts.
- Check the lubrication of roller. Lubricate it if drag phenomenon exist.



- The machine should be lower to the lowest position when replace hydraulic oil, then let the old oil out, and should be filtering the hydraulic oil.
- Each team checks the agility and reliability of pneumatic safety equipment.

Storage after use

When the machine does not use for a long time:

- Cut off the power supply and lubricate all the active parts.
- Drain the hydraulic oil of oil cylinder, oil hose and oil tank.
- Sheathe the machine with dust-proof cover.

7. Circuit diagram

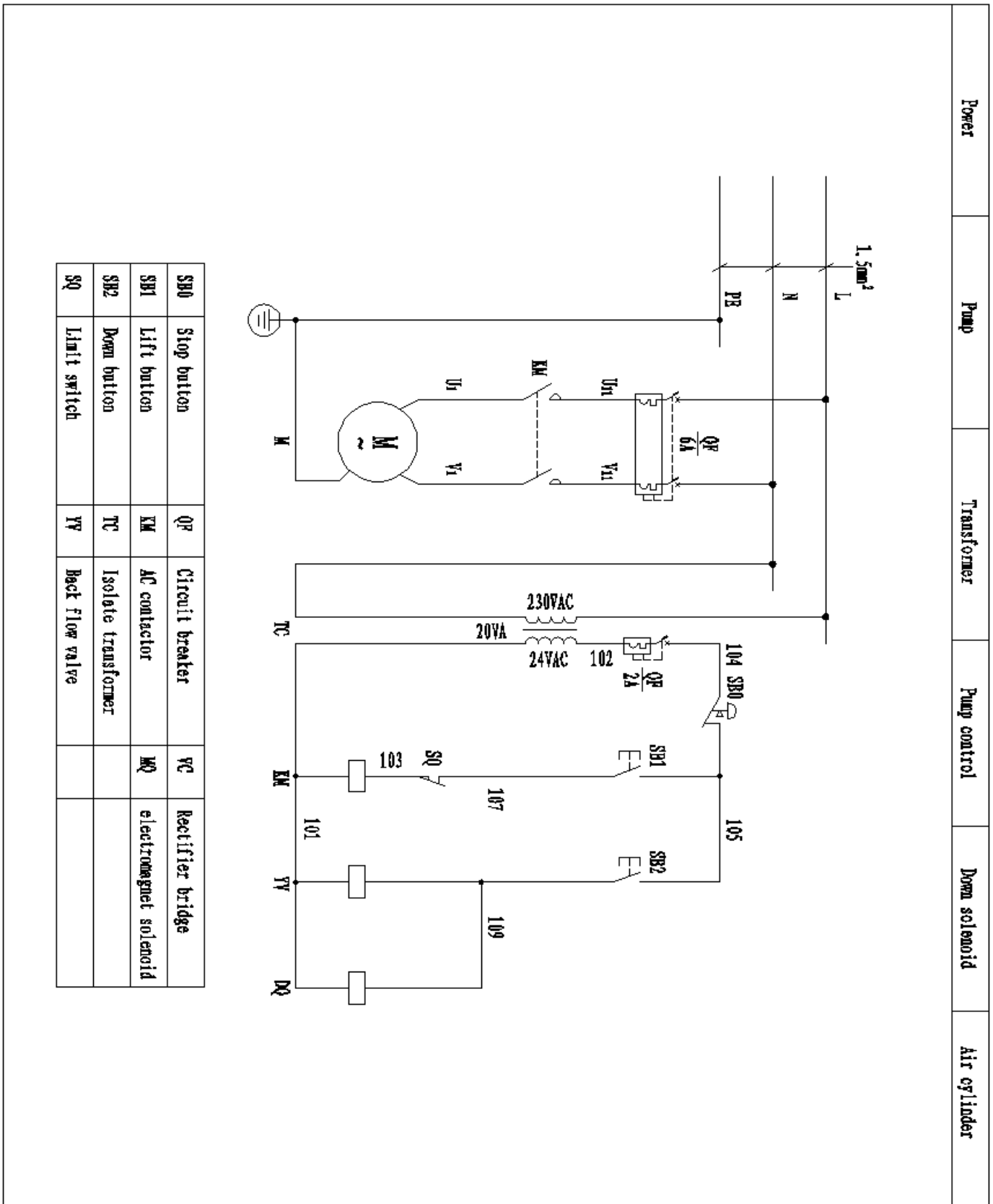

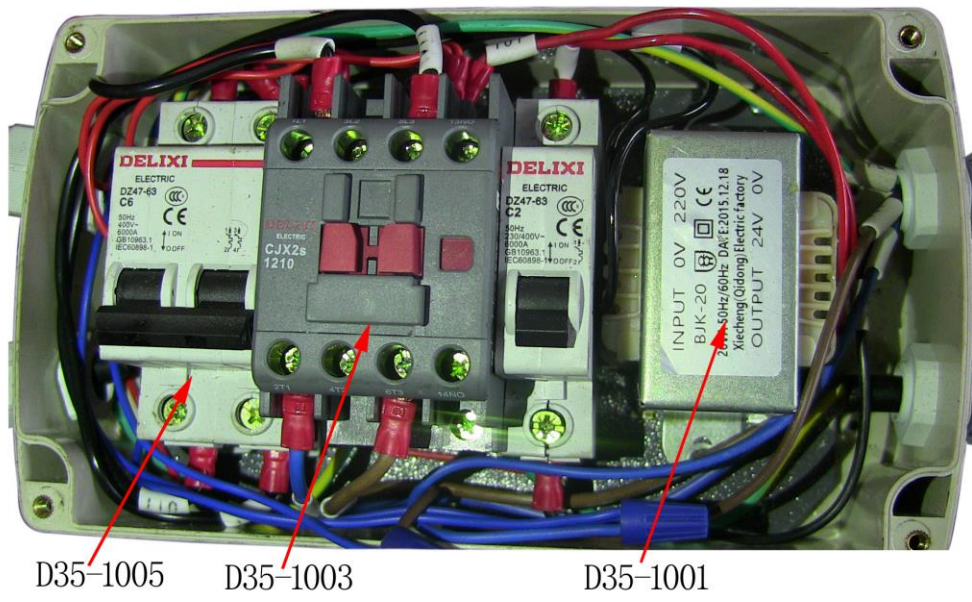

D35-1005		Circuit breaker
D35-1003	H-030-050011-1	AC contactor
D35-100		Transformer

8. air loop diagram

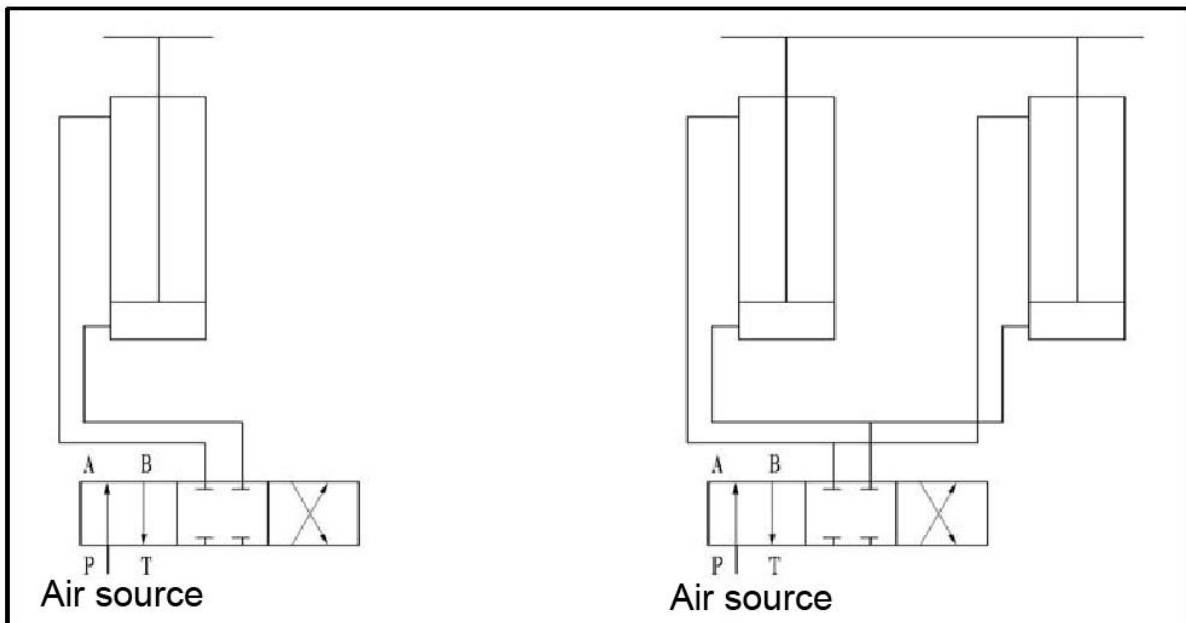

M01

M02

9. Explosion drawing

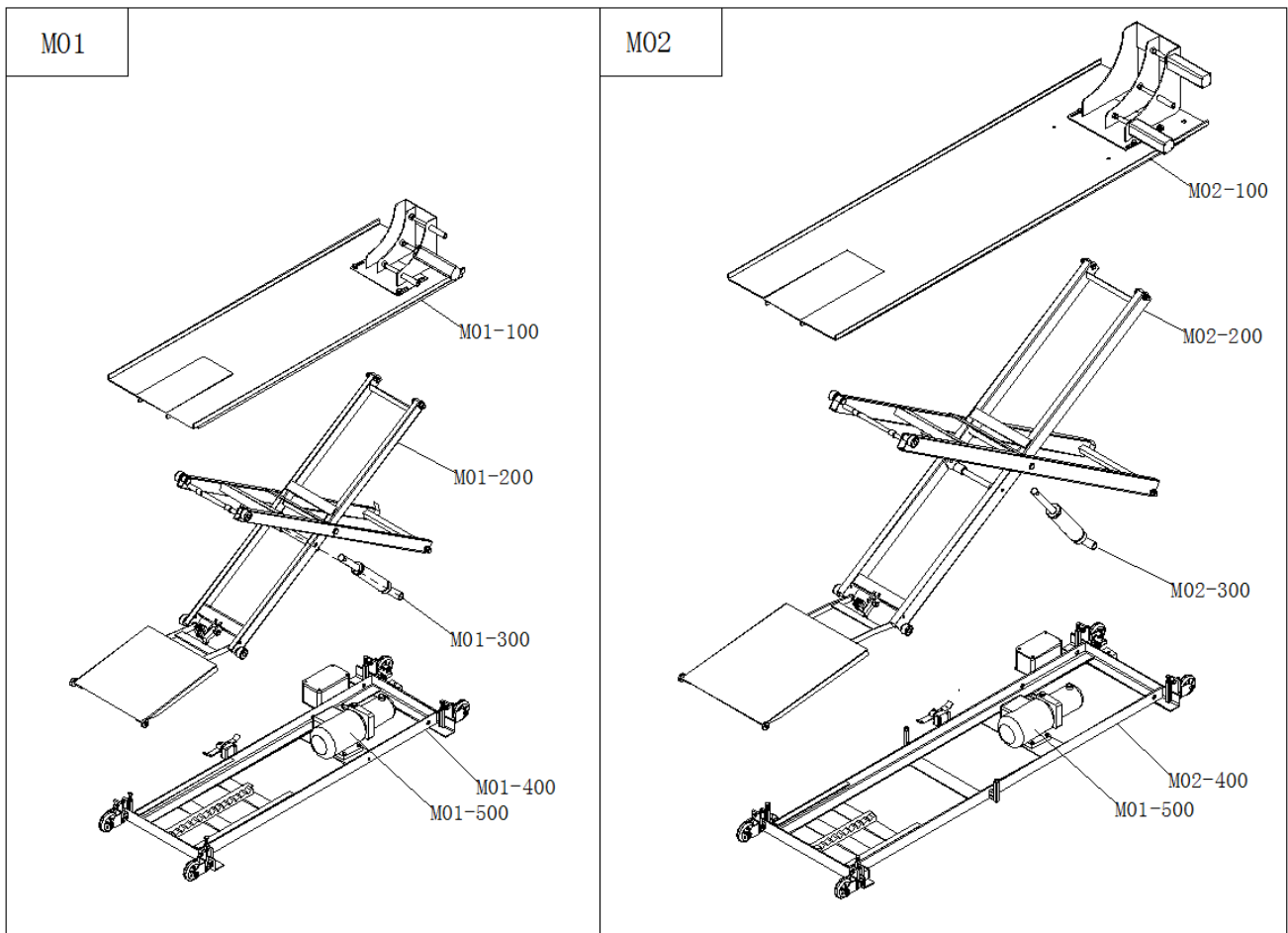

M01-100	Complete platform assembly
M02-100	Complete platform assembly
M01-200	Complete connecting rod assembly
M02-200	Complete connecting rod assembly
M01-300	Complete oil cylinder assembly
M02-300	Complete oil cylinder assembly
M01-400	Complete base seat assembly
M02-400	Complete base seat assembly
M01/M02-500	Complete power unit assembly

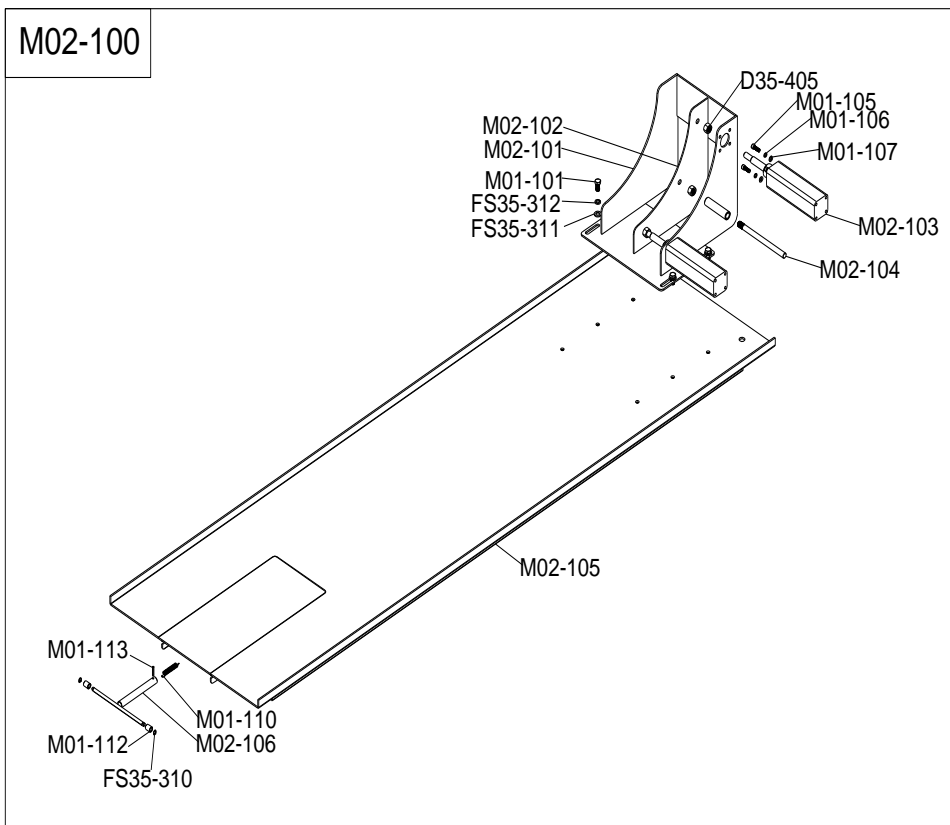
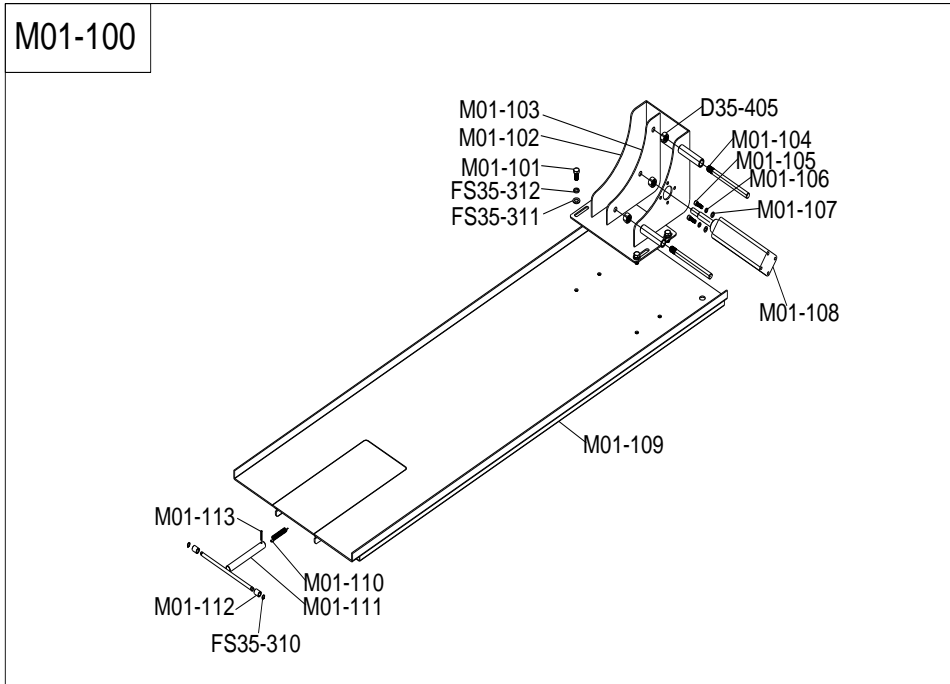

FS35-311	flat washer Ø12
FS35-312	spring washer Ø12
M01-101	hex bolt M12X25
M01-102	clamp assembly
M01-103	pressing plate

D35-405	nut M16
M01-104	Guide rod
M01-105	hex socket head cap screw M8X25
M01-106	spring washer Ø8
M01-107	flat washer Ø8
M01-108	clamping cylinder SC50X125
M01-109	platform
M01-110	spring
M01-111	guide tube
FS35-310	shaft snap ring Ø10
M01-112	roller
M01-113	straight pin
M02-101	clamp assembly
M02-102	pressing plate
M02-103	air cylinder
M02-104	Guide rod
M02-105	platform
M02-106	guide tube

M01-200
M02-200

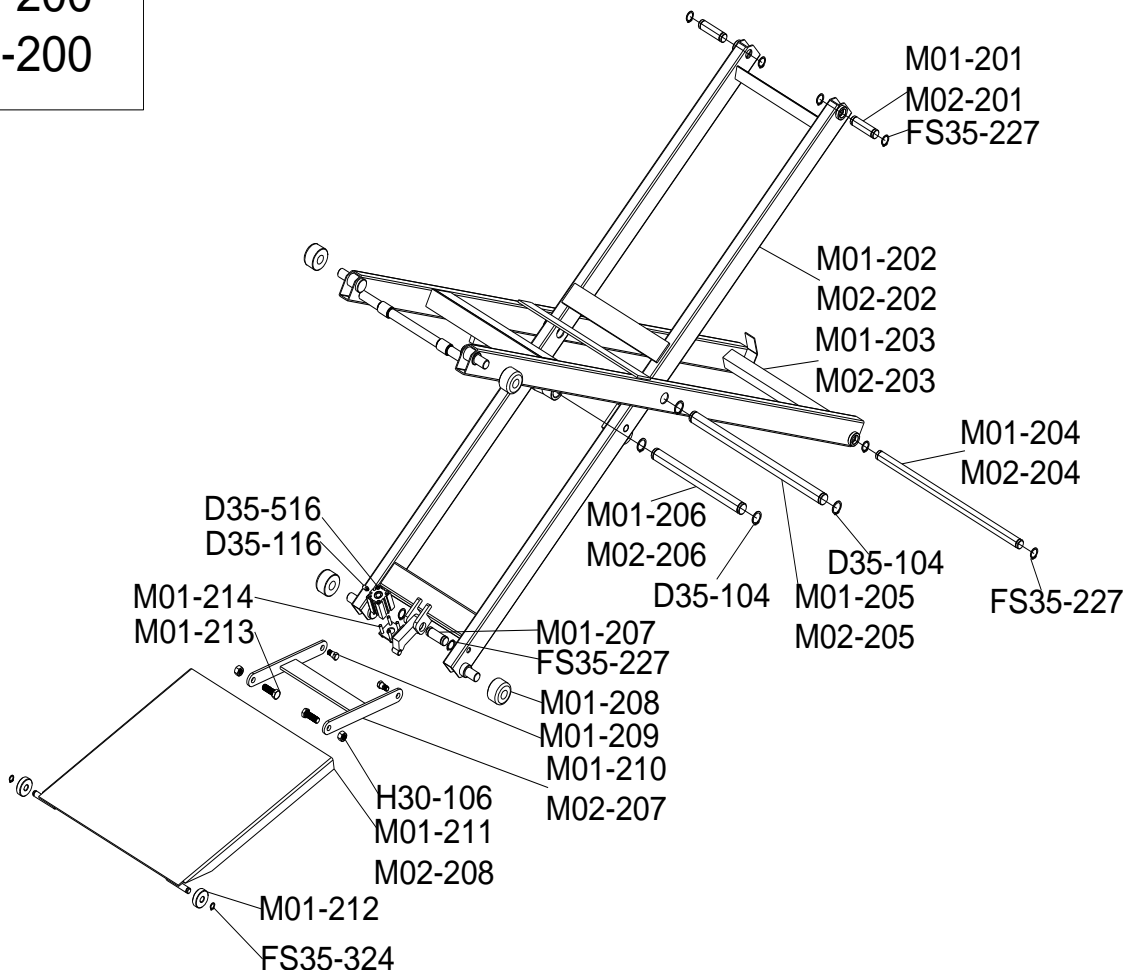

M01-201	top plate pin
M02-201	top plate pin
FS35-227	shaft snap ring Ø20
M01-202	Inner connecting rod
M02-202	Inner connecting rod
M01-203	Outer connecting rod
M02-203	Outer connecting rod
M01-204	base pin
M02-204	base pin
D35-104	shaft snap ring Ø25
M01-205	connecting rod pin
M02-205	connecting rod pin
M01-206	Stationary shaft of oil cylinder
M02-206	Stationary shaft of oil cylinder
M01-207	insurance claw shaft
M01-208	roller
M01-209	bolt
M01-210	loading dock board support
M02-207	loading dock board support
H30-106	hex nut M12
M01-211	loading dock board
M02-208	loading dock board
FS35-324	shaft snap ring Ø12
M01-212	loading dock board roller
M01-213	hex bolt M12X35
M01-214	hex socket head cap screw M6X25
D35-516	cylinder SSSA25X25

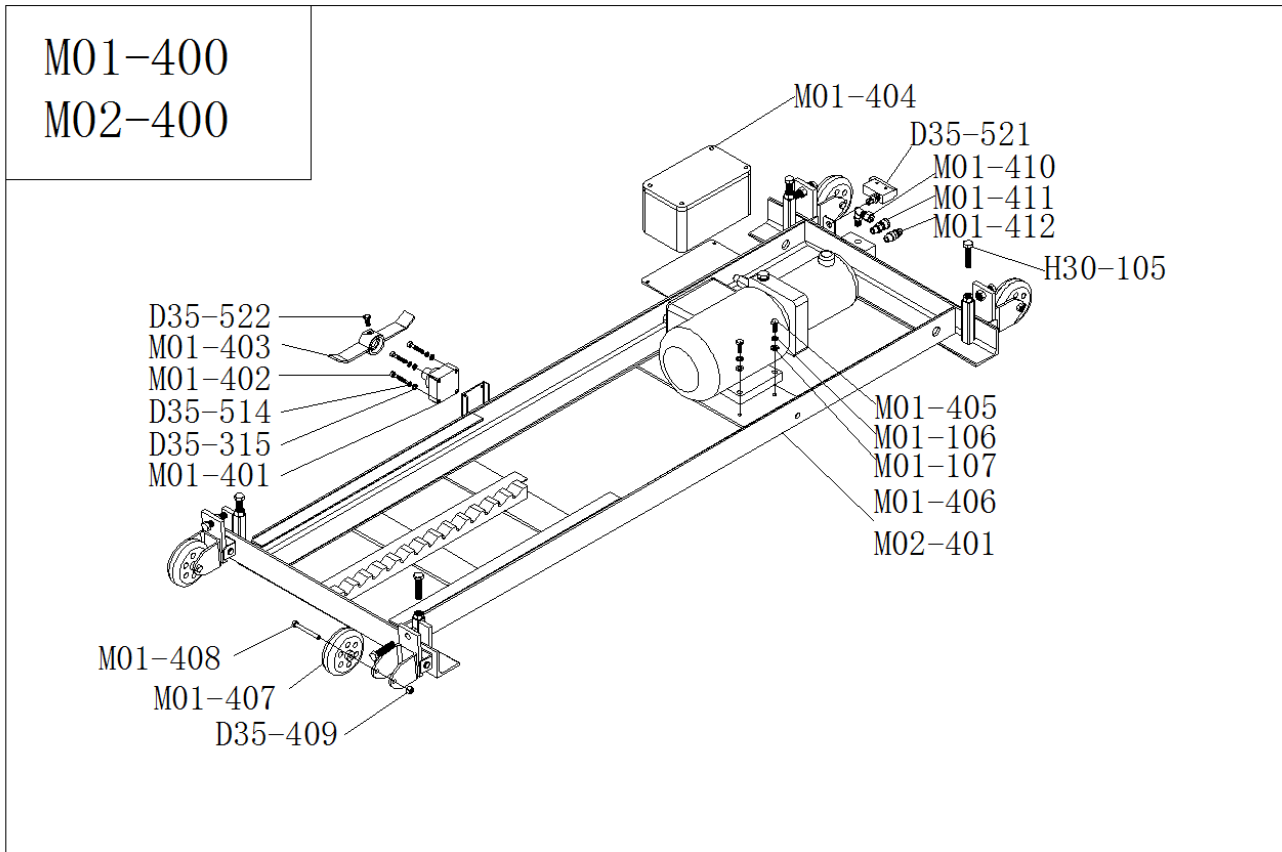

M01-400	base complete
M01-401	Foot valve
D35-515	flat washer Ø6
D35-514	spring washer Ø6
M01-402	hex socket head cap screw M6X35
M01-403	air pedal
D35-522	hex bolt M8X16
M01-404	Electric control box
D35-521	limit switch LZ7312
H30-105	hex bolt M12X50
M01-405	hex bolt M8X20
M01-106	spring washer Ø8
M01-107	flat washer Ø8
M01-406	base
M02-401	base
M01-407	caster
M01-408	hex bolt M8X65
D35-409	hex nut M8
M01-409	bend connector
M01-410	quick connector(female)
M01-411	quick connector(male)

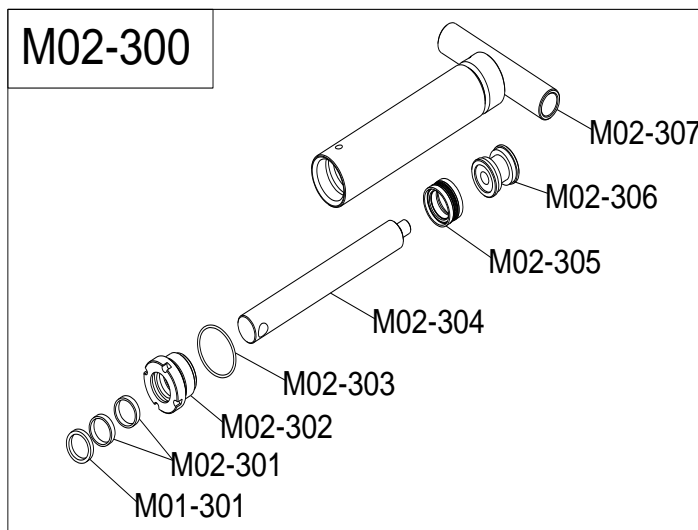
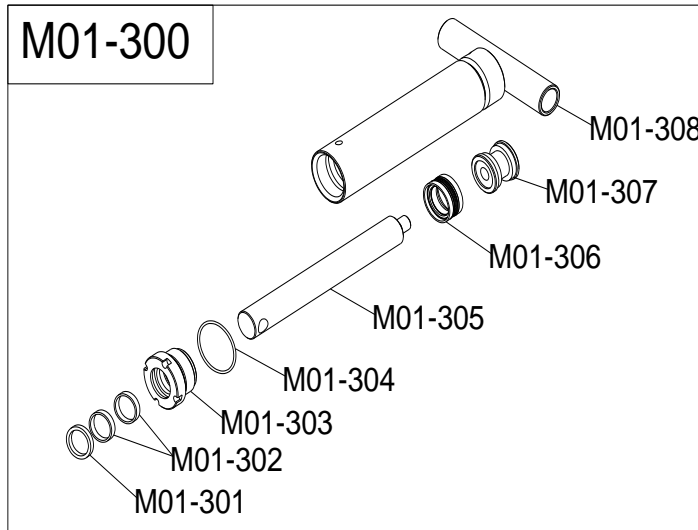



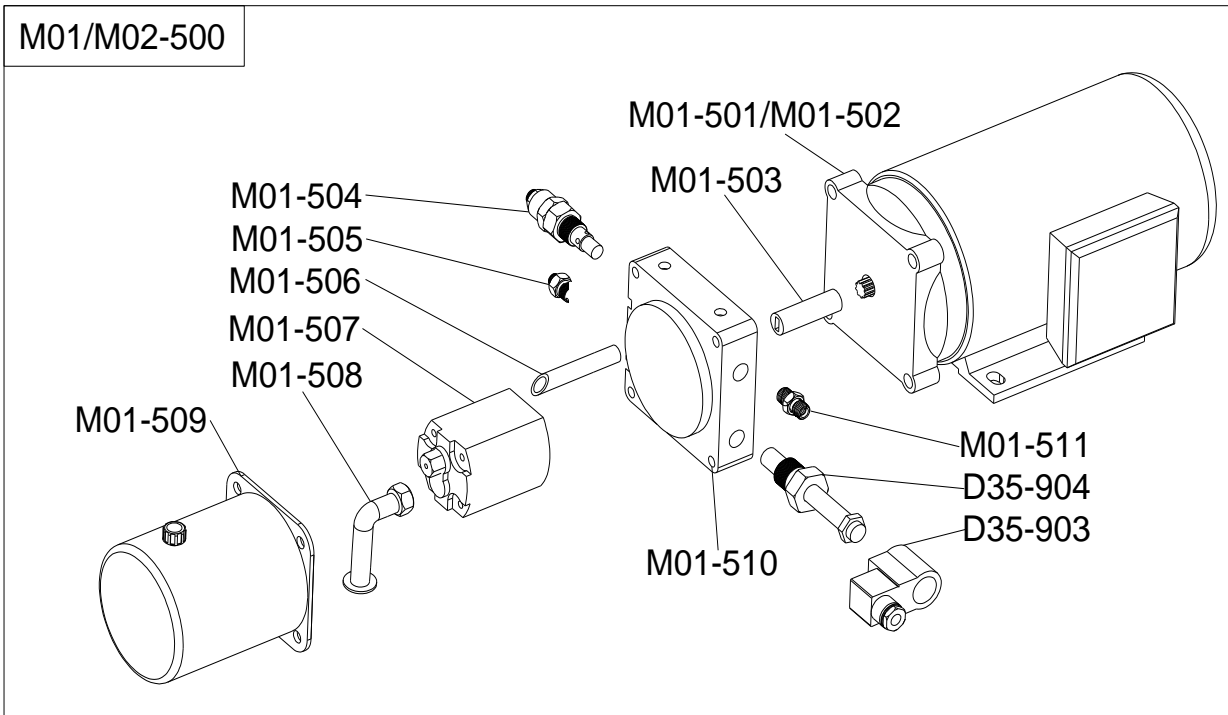

M01-301	dust-proof ring Ø32X40X5.3
M01-302	Wear ring
M01-303	oil cylinder cover
M01-304	O-ring Ø45X3.55
M01-305	piston rod
M01-306	combined seal ring Ø45X29X18.4
M01-307	piston(
M01-308	oil cylinder

M01-301	dust-proof ring Ø32X40X5.3
M02-301	Wear ring
M02-302	oil cylinder cover
M02-303	O-ring Ø45X3.55
M02-304	piston rod
M02-305	combined seal ring Ø45X29X18.4
M02-306	piston
M02-307	oil cylinder



M01-501	1 phase motor(M01,M02)
M01-502	3 phase motor(M01,M02)
M01-503	Annectent spinde (M01,M02)
M01-504	Overflow valve(M01,M02)
M01-505	Plug(M01,M02)
M01-506	Escape oil hose(M01,M02)
M01-507	Gear pump(M01,M02)
M01-508	Suction oil hose(M01,M02)
M01-509	Oil tank(1.5L) (M01,M02)
M01-510	Valve seat(M01,M02)
M01-511	Oil hose connector(M01,M02)
D35-904	Lowering valve(M01,M02)
D35-903	Lowering coil(M01,M02)

10.Accessories Packing List

Name	Pic	Spec.	Qty
1. Air Cylinder union		φ6*4	1pc
2. Air hose T-union		φ6*4	1pc
3. Air hose straight union		φ6*4	1pc
4. Air hose bend union		φ6*4	1pc
5..Use manual		(including instruction manual, certificate of soundness, warranty bill and packing list)	1pc