

71.TTC-L

71.TTC-L HAMMERHEAD TRUCK WHEEL BALANCER INSTRUCTION & MAINTENANCE MANUAL



Jimmy Industrial Pty Ltd
5 Cord St
Dudley Park, 5008
Ph: (08) 8269 9700
W: www.jimmytools.com.au
E: sales@jimmytools.com.au



Read this entire manual carefully and completely before installation or operation of the lift

1. GENERAL INFORMATION

1.1. Product description

The T980 super tyre changer has been specifically designed to demount and mount truck, bus, tractors and earth moving vehicles tyres, with rims from 14" to 56" and a maximum 2300mm diameter.



Warning!

Any other use is improper and therefore not authorized. Before beginning any kind of work on or with this machine, carefully read and understand the contents of these operation instructions.

Any other use is improper and therefore not authorized. Before beginning any kind of work on or with this machine, carefully read and understand the contents of these operation instructions.

Yingkou Tongguang shall not be liable for any injury to persons or damage to things caused by improper use of this machine.

1.2. Product identification

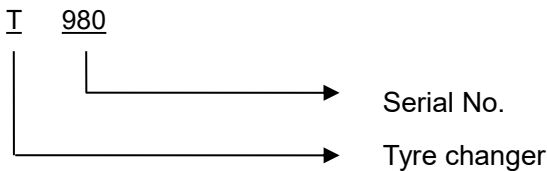

1.3. Technical Data

- a.
- b. Power supply 415V/3ph
- c. Frequency 50Hz
- d. Power 6.0kW
- e. Full load Current 12A
- f. Short-current capacity 6kA
- g. Rim diameter capacity 14"-56"
- h. Max wheel weight 900kg
- i. Max wheel diameter 2300mm
- j. Total weight approx. 1,000kg

2. Technical data

2.1. Main technical parameter

- k. Rim Diameter: 14" ~56" (Φ356mm~Φ635mm)
- l. Max. Diameter of Tyre: Φ2300mm
- m. Max. Breadth of Tyre: 1000mm
- n. Max. Weight of Tyre: 1,000kg
- o. Main shaft Motor Power: 3.0kW./400V/50Hz
- p. Hydraulic Station Motor Power: 3.0kW/400V/50Hz

- q. Hydraulic System Rated Working Pressure: 15MPa~18MPa
- r. Max. Hydraulic System Working Pressure: 20MPa
- s. Oil Tank Volume: 400mmx250mmx200mm
- t. Hydraulic Oil: YB-N 64, YB-N32
- u. Hydraulic operating temperature range: *****
- v. Noise : $\leq 70\text{dB}$
- w. Weight: 1,000 kg
- x. Outfit Dimension (L*W*H): 1380mmx1700mmx800mm
- y. Package Carton Outfit Dimension: 2300mmx2100mmx1300mm

2.2. Operation environment condition

- a. Temperature: $+5^{\circ}\text{C}\sim+40^{\circ}\text{C}$.
- b. Humidity: 50% @ 40°C , (90% at 20°C)
- c. Altitude: $\leq 1000\text{m}$
- d. Power supply voltage: 400V voltage fluctuation $<\pm 10\%$
- e. Power supply frequency: 50Hz frequency fluctuation $<\pm 1\%$

It is also require that the dust content in the air $\leq 10\text{mg}/\text{m}^3$. And it must not in the air with the corrosive and toxic gas and keep away from the area of flammable and explosive.

3. Transport and storage

3.1. Transport

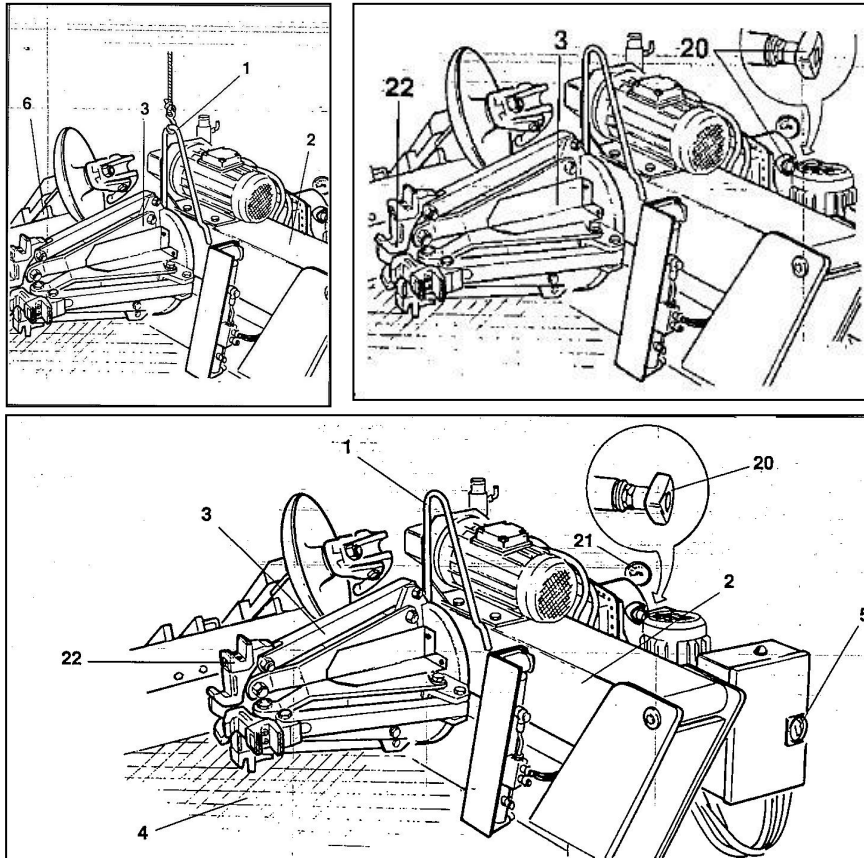

Fig. 3.1

The Worker product has got a fork (1, Fig. 3.1) which has been positioned there on purpose for moving the machine. Follow, these instructions:

- 1) Low the turntable holding arm (2, Fig. 3.1) completely down..
- 2) Close completely the jaws of the chuck (3, Fig.3.1).
- 3) Bring the bead loosener disk up against the lifting bracket (1, Fig.3.1), 20cm nearly with the arm (14 Fig.6.3) closed on work position.
- 4) Insert into the lifting fork a hoisting belt (at least 60 mm wide and of a length sufficient to bring the hook of the belt above the tyre changer).
- 5) With the special belt ring bring the 2 ends of the belt together and lift with a sufficiently strong lifting truck.

And then the product should be packaged in a wooden crate with pallet. And the machine protected by a plastic covering.

Before moving the machine check its barycentre and weight to make sure they are compatible with the lifting equipment you are about to use.

To move the packed machine insert the forks of a pallet truck in the channels in the base of the pallet (Fig. A/1).If you are moving the machine with a crane or hoist (Fig.3.3), use approved web slings or cables.

The shipping weight for the machine is nearly 1,500kg.

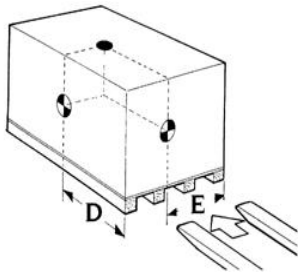

Fig.3.2

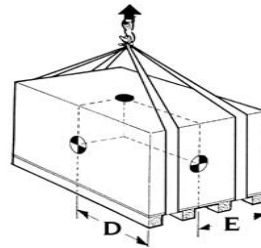

Fig.3.3

3.2. Storage

Temperature of the machine storage premises:-25~+55°C

If the machine as to be stored for a long time (3~4 month or more) you have to:

- 1) Close the jaws of the chuck, low the chuckholding arm down, in working position.
- 2) Disconnect the machine form all power sources.
- 3) Grease all the parts that could be damaged if they dry out:
 - The chuck
 - The slot of the tool holding arm
 - The slides of the carriage
 - The tool

Empty oil/ hydraulic fluid reservoirs and wrap the machine in a sheet of protective plastic to prevent dust form reaching the internal working parts.

If the machine as to working again after a long storing period, it is necessary to:

- Put the oil into the reservoirs again.
- With a turn screw press the pin on the middle of the electro-valves (See Fig. 3.4) in order to manually unlock the electro-valves which could be locked after a long period of inactivity.
- Restore the electric connection.

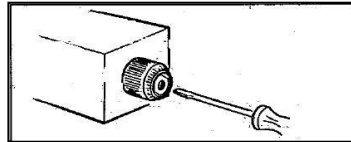

Fig.3.4

4. Unpacking

Once the packing material has been removed, check the machine visually for any signs of damage.



ATTENTION!

Keep the packing material out of the reach of children as they can be a source of danger.

5. Installation

5.1. Installation place

Choose the place the machine is to be installed in compliance with current work place safety regulations. The floor should be solid so that the machine will be stable.

The tyre changer must be fixed on cement ground by anchor bolts fastened through its 4 base frame holes. The tyre-changer must be fixed to the ground by means of suitable anchoring bolts. The requirement of the ground and the anchor is as below in Fig.5.1, Fig.5.2 and Fig.5.3.

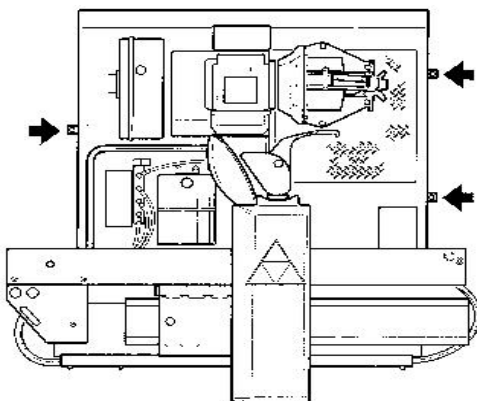

Fig.5.1

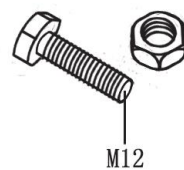

Fig.5.2

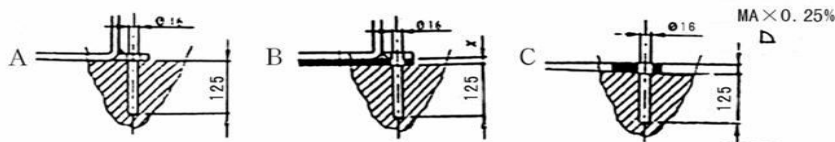
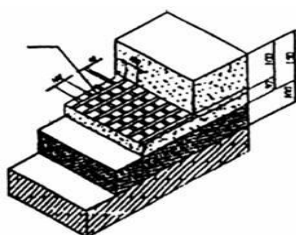

Fig.5.3



ATTENTION! *The machine must not be operated in explosive atmospheres.*

5.2. Workplace requirement

Maximum machine space requirements are 2442mm x 2030mm with a minimum distance from walls as shown in the Fig.5.4. Make sure that the installation place is as least 3 meters high.

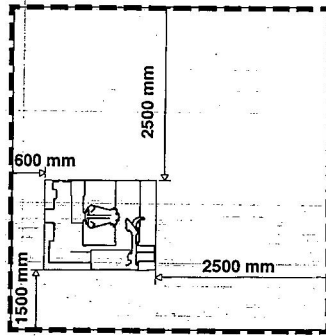

Fig.5.4

5.3. Electric connection

Before making any electric connection, check to be certain that the mains voltage corresponds to that stamped on the nameplate.

It is absolutely essential that:

- the system is equipped with a good grounding circuit
- The machine is connected to a power supply line circuit breaker. The power supply cable should be at least $3 \times 1.5 \text{ mm}^2 + 1.5 \text{ mm}^2$. And the power supply cable should be marked L1, L2, L3 and PE.
- The current intake is adequately protected against overcurrent with fuses or automatic magneto-thermic switch with rated values 25A.

WARNING: Make sure the feeder can move freely once it has been connected to the electric mains and that it can follow the tool-holding arm without being damaged.



Work on the electric system, even if minor, must be done exclusively by professionally qualified personnel.

Manufacturer shall not be liable for any injury to persons or damage to things caused by failure to comply with these regulations and can cancel warranty coverage.

Sense of rotation checks

Connect the machine to the mains, switch "ON" (5, Fig.3.2) and check that the gearbox motor rotation corresponds to the indicating arrow (6, Fig. 5.5). If not, switch two wires of the phase conductors.

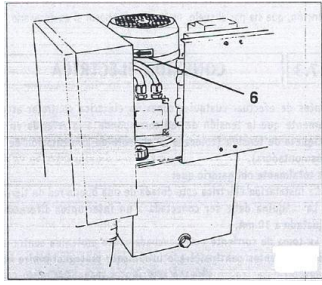
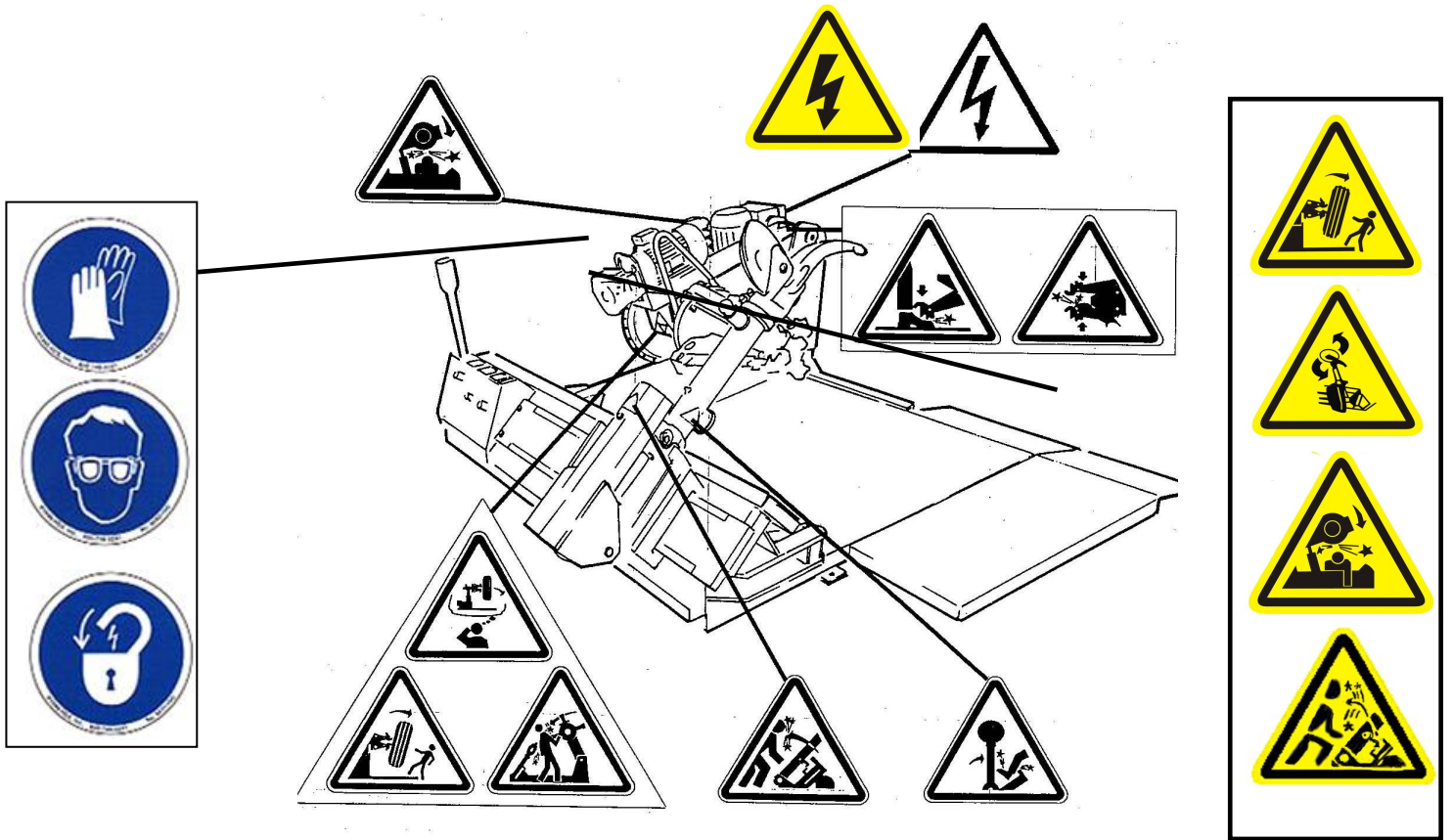

Fig.5.5

6. Preparation and Identifying controls

6.1. The warning label instruction



Hand-crushing hazard between turntable jaws.



Mind to the tool-holding arm during tilting or operating.



Feet-crushing hazard during turntable turning or operating



Do not leave working place if the wheel is still mounted on the turntable.



Take care to crushed hazard between turntable arm and tyre changer body.



Take care to crushed hazard between turntable and tool.



Take care to crushed hazard during tool holding arm re-hoking.



When the beads come off the rim, the wheel will fall.
Check to make sure there are no by-standers-in the work area.



Take care to the rotation of the tool disk to harm the operator.



The accidental fall down of the tool head for out of control can cause the injury!



Always check to be certain that the arm is corrected hooked to the carriage.



Danger: electric voltage presence.



The operator must wear the safety glove, when operating the machine.



The operator must wear the eye protection, when operating the machine.



Please lockout electrical power before performing maintenance work and set the machine to its rest position (Fig.5) with the spindle arm lowered and the spindle completely closed.

6.2. Layout of functional parts

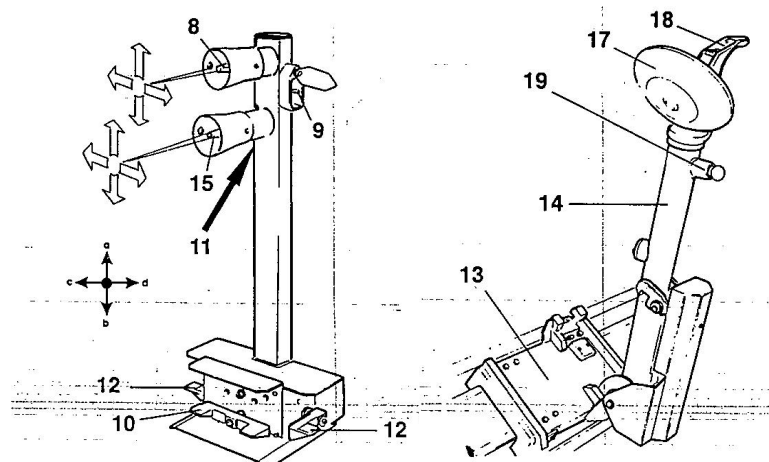

Fig.6.1

- | | |
|-------------------------------------|------------------------|
| 1. Lifting bracket | 12. 2nd-speed pedals |
| 2. Self-centering chuck holding arm | 13. Carriage |
| 3. Self-centering chuck | 14. Tool holding arm |
| 4. Sliding table | 15. Bottom joystick |
| 5. Main switch | 16. Bead breaking disk |
| 8. Top joystick | 17. Tool |
| 9. Switch | 18. Tool handle |
| 10. Pedal | 19. Pressure handle |
| 11. 2nd-speed switch | 20. Manometer |
| | 21. Jaw |

6.3. Identifying controls

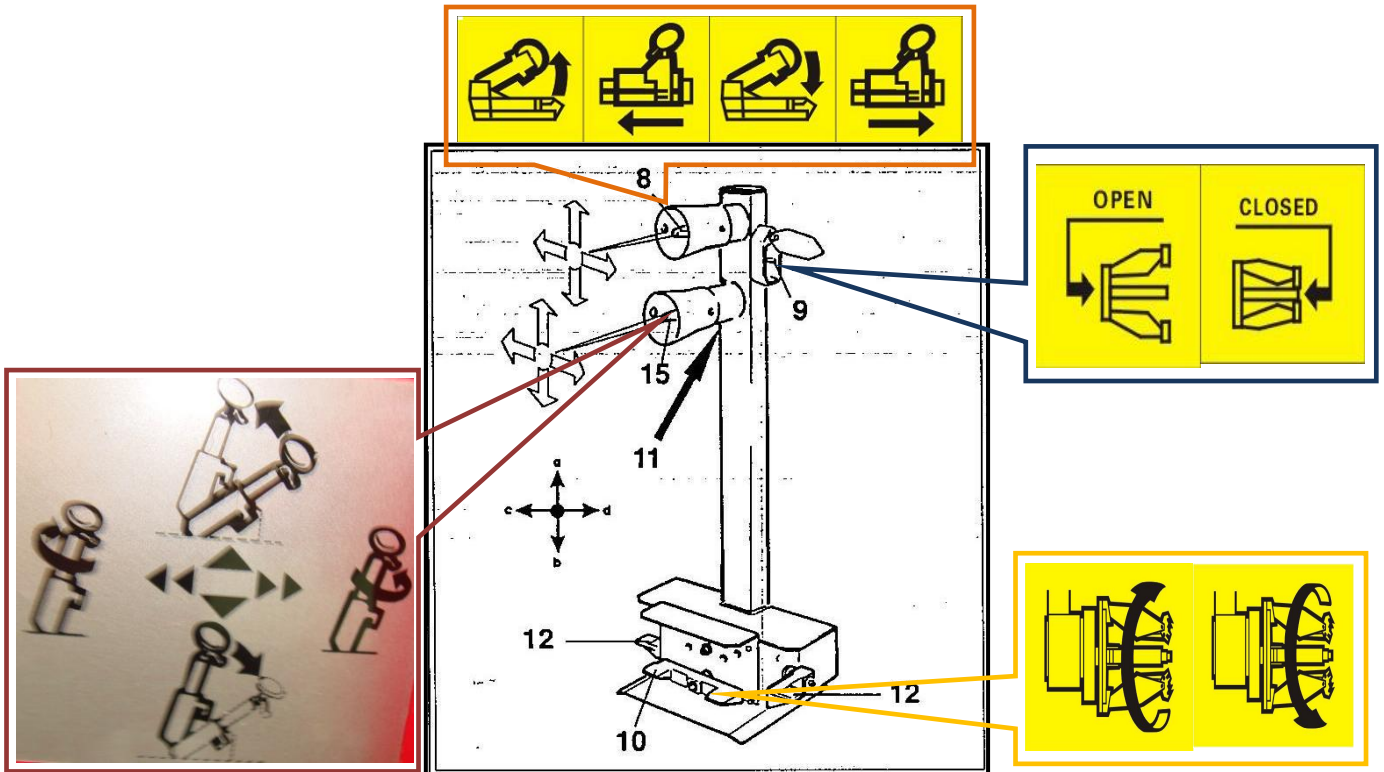

Fig.6.2

The mobile control centre (Fig.6.2) enables the operator to work at any position around the machine. On this mobile control centre the following controls are located:

1. **The top joystick (8, Fig.6.2)** which in **position a** lifts the chuck arm and in **position b** lowers it; in **position c** moves the chuck rightwards and the tool holder arm leftwards simultaneously (so they get nearer each other) and in **position d** moves the chuck leftwards and the tool holder arm rightwards (so they get farther each to the other).

Note: On the lever protection, a hole corresponding to **position c** has been made, in order to recognize each different operation.

2. **bottom joystick (15, Fig.6.2)** when pulled **upwards a**, the bottom joystick brings the tool holding arm in "non working" position, when pulled **downwards b**, it brings the arm in "working" position when putted **leftwards c**, it turns the head tool through 180° counterclockwise; when putted **rightwards d**, it turns the head tool to the opposite direction and brings the tool back to starting position.

Note: to make it easier to remember these **position "c"** is identified by a hole drilled in the guard.

3. **The chuck switch (9, Fig.6.2)** when moved upwards, opens the arms of the self-centering chuck (LOCKING), and when moved down, closes the arm of the self-centering chuck (UN-LOCKING).
4. **The pedal (10, Fig.6.2)** when pressed on the left or right side rotates the self-centering chuck in the same direction as shown by the arrows placed on the foot pedal.
5. **The second speed switch (11, Fig.6.2)** when pressed together with the pedal (10,

Fig.6.2), rotates the self centering chuck at high speed.

6. **The second speed pedals (12, Fig.6.2)** move the self-centering chuck and the tool holding arm and close and open the carriage at high speed.

NOTE: all the controls are very sensitive and small movements of the machine can be done with precision.

On the Worker tyre changer there is also a knob (19, Fig.6.3) which allows to replace tools (for instance for mounting accessory RT Tubeless roller).

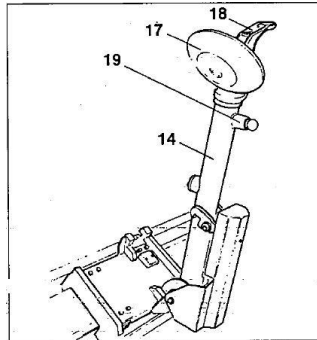

Fig.6.3

6.4. Work position

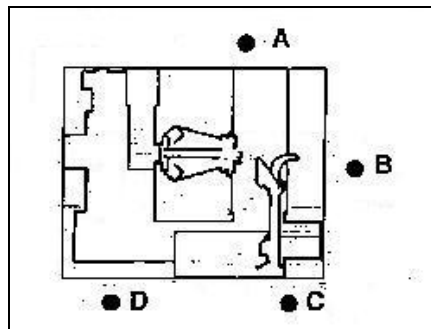

Fig.6.4

The Fig.6.4 illustrates the various working positions (A, B, C, D) referred to in the following pages describing how to use the tyre changer.

Use of these positions ensures greater precision, speed and safety for those using the machine.

6.5. Preparation

Before using the tyre changer, a number of checks should be made to ensure it works correctly.



CAUTION! The operations described here should be done with the tool carrier arm in its non-working position.

- 1) Move the bottom joystick (15, Fig.6.2) upwards (a) the tool arm (14, Fig.6.3) must be tilt in "non-working" position.



CAUTION!

Do not move your face close to the tool carrier arm when you release it to tip it as needed.

move the joystick downward (b): the tool holding arm must hook in "working" position.



CAUTION!

The tool-holding arm hooding creates a potential crushing hazard.

move the bottom joystick leftwards (c): the tools must rotate anticlockwise by 180°,
move the joystick rightwards (d): the tools must rotate in the opposite direction and return to its initial position.

- 2) Tool holding arm being in "non-working" portion move the top joystick (8, Fig.6.2) up (a): the spindle carrier arm (2, Fig.3.1) should lift; move the joystick down (b): the arm should, lower.

DANGER!

When the spindle carrier arm is lowered, there is always a potential for crushing anything in its movement range. Always work from the position given in the instructions keep well out of the working range of the various moving arms.



move the joystick leftwards (c): the spindle-holding arm (2, Fig.3.1) must move rightwards and the tool-holding arm (14, Fig.6.3) leftwards; moving at the same time, the two arms must get closer,

move the joystick rightwards (d): the spindle-holding arm must move leftwards and the tool-holding arm rightwards, this parting.

Repeat these operations ("c" and "d") simultaneously pressing one of the two pedals (12,

Fig.6.2): the above indicated movements must occur at high speed.

- 3) Turn switch lever (9, Fig.6.2) towards the top: the spindle arms (3, Fig.3.1) should open; move the lever down and the spindle arms should close.

Repeat these operations simultaneously pressing one of the two pedals (12, Fig.6.2): the above indicated movement must occur at high speed.



DANGER!

When the spindle arms open or closed, there is always a potential for crushing anything in their movement range. Always work from the position given in the instructions keep well out of the spindle's working range.

- 4) Depress the right pedal (10, Fig.6.2): the spindle (3, Fig.3.1) should turn clockwise, depress the left pedal: the spindle should turn anticlockwise.

Pull the switch lever (11, Fig.6.2) down and repeat the above indicated operations: the spindle must move at high speed.

- 5) Check to be certain the hydraulic circuit is working-correctly:
 - move switch lever (9, Fig.6.2) towards the top until the spindle arms are fully extended.
 - hold the switch lever in this position (top) and check if the pressure shown on the manometer (21, Fig.3.1) is 130 bar *5%.

ATTENTION: If the pressure value is not within the above indicate range see the "TROUBLE SHOOTING" at this manual to solve this problem.

If the pressure shown in the manometer, is stilt not within this range, do not use the tyre changer and call for technical aid.

7. Operation

7.1. Locking the wheel



WARNING!

Handling of wheels

- up to 35kg, handling must reasonable for one person, no special handling aid required (refer also to EN 1005).
- up to 70kg (max. 80kg), handling must reasonable for two persons (check also for space requirements and instructions) or handling/lifting aids provided.
- above 70kg , handling or lifting system required.

1. Take the mobile control unit to work position B.
2. Pull the tool-holder arm into the upright position.

3. Move the top joystick and move the turntable leftwards thus creating enough space for the wheel to be mounted on the platform. Keep the wheel in vertical position.
4. Continuing to operate from the mobile control centre, lift or lower the arm in order centre the self-centering chuck (3, Fig.3.1) relative to the rim.
5. With the jaws (22, Fig.3.1) in the closed position, move the wheel on the sliding table to the self-centering chuck. Operate the chuck switch (9, Fig.6.2) to open the self-centering chuck and lock onto the inside wheel rim.

The most convenient locking position on the rim may be selected according to figs 7.1.1, 7.1.2, 7.1.3, 7.1.4, 7.1.5, 7.1.6.

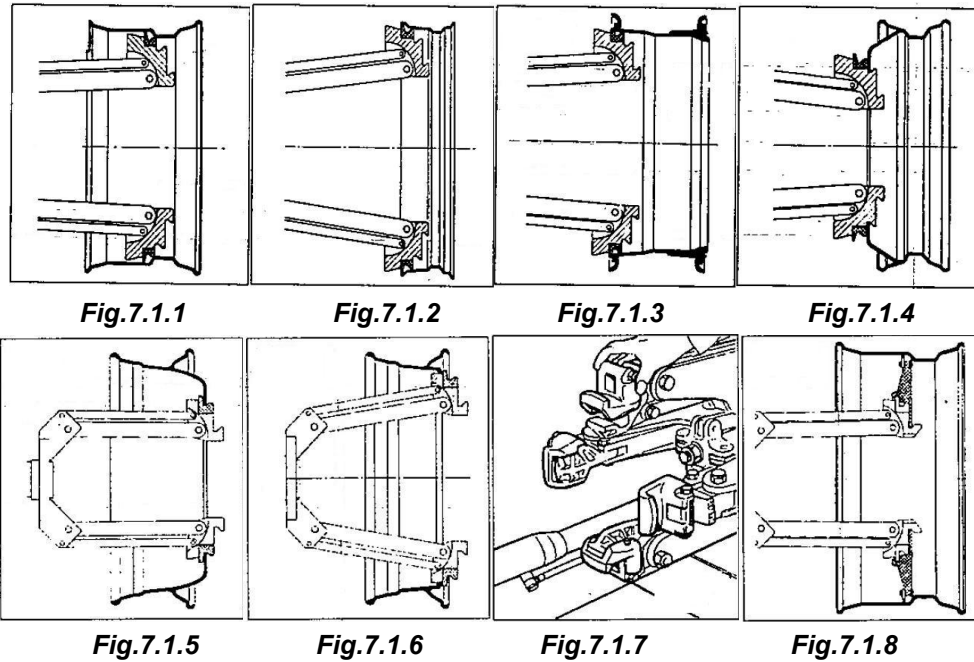

Always remember that the safest locking is on the central flange.

N.B. for rims with channel, clamp the wheel so that the channel is near the outside of the rim (Fig.7.1.1).

7.1.1. Light-alloy rim locking

The GL clamps - especially designed for operating on light alloy rims without damaging them -- are available upon request.

The GL clamps are to be inserted (bayonet-like mounting) into the clamp support of the self-centering chuck (see Fig. 7.1.7). Thanks to a wing screw the clamp can be locked on the support. Lock the rim as illustrated in Fig. 7.2.

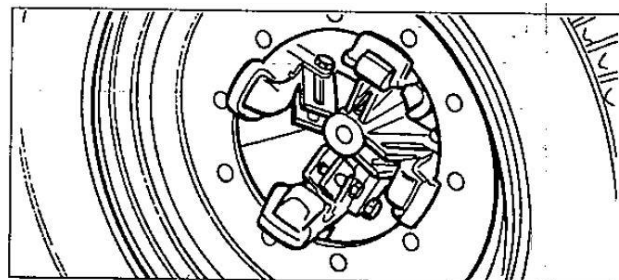

Fig.7.2

The specially-made PL alloy-rim pliers are also available.



DANGER!

Do not vary the work area with a wheel clamped on the tyre changer and lifted up from the floor.

7.1.2. Clamp extensions

For rims with diameters over 46" without central hole flange, the wheel can be clamped with the PA extensions (optional). Insert the clamp extension into the clamp support of the self-centering chuck arm (bayonet mounting) and lock it with the wing nut (see Fig.7.1.8).

7.2. Tubeless and supersingle wheels

7.2.1. Bead breaking

- 1) Lock the wheel on the self-centering chuck, as previously described, and ensure that the tyre is deflated.
- 2) Take the mobile control unit to work position C.
- 3) Lower the tool-holder arm (14, fig. F) into its working position and allow it to lock.
- 4) Operating from the mobile control centre, manoeuvre the wheel until the outside of the rim skims the bead-breaker disk (fig. F).

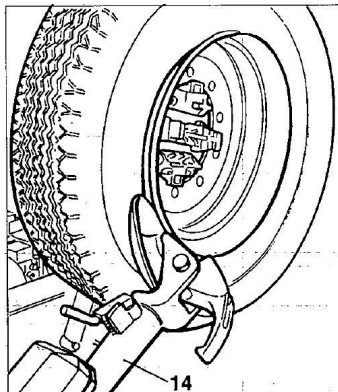

Fig.7.3



DANGER!

Always check to be certain that the arm is correctly hooked to the carriage



DANGER!

The bead breaker disk must NOT be pressed against the rim but against the tyre bead.

- 5) Rotate the wheel and at the same time, advance the bead-breaker plate with small forward movements following the profile of the rim, with the plate.
- 6) Continue until the first bead is fully detached.

To facilitate this operation, lubricate the bead and the edge of the rim with tyre lubricant whilst the wheel is rotated.



DANGER!

To avoid all risk, lubricated the beads turning the wheel **CLOCKWISE**, if you are working on the outside plane. And turning the wheel **ANTICLOCKWISE**, if working on the inside plane.

Remember that the stronger the tyre's adherence, to the rim, the slower must be the disk's penetration.

- 7) By using the bottom joystick (15, Fig.6.2) tilt the arm to 'non working" position; move and lock it in the inner position (Fig.7.4).

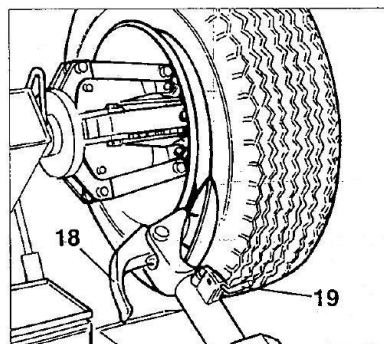

Fig.7.4



DANGER!

Do not hold your hands on the tool when you bring it back to its work position. Your hand(s) could be trapped between the tool and the wheel.

- 8) By using the top joystick move the spindle and the tool-holding arm until the arm is brought near the inner side of the wheel.
- 9) By using the bottom joystick bring the arm back to working position and rotate the tools by 180°.
- 10) Take the mobile control unit to work position D
- 11) Repeat the operation previously described until the second bead is completely broken.

N.B.: During the bead breaking, the claw (18, Fig.7.4) can be towered so that it is out of the way.

7.2.2. Demounting

Tubeless tyres can be demounted in two ways:

1) If the tyre is not difficult to demount, once the beads have been loosened, use the bead disk to push against the inside plane of the tyre until both beads come off the rim (See Fig.7.5).

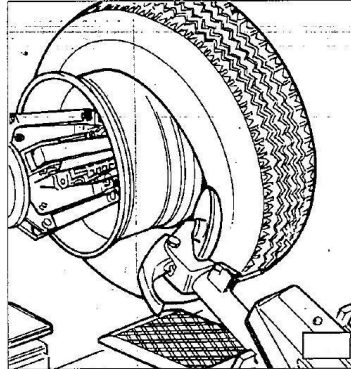

Fig.7.5

2) With super single or very hard tyres the procedure described above cannot be used. The hook tool will have to be used as follows:

- A. Transfer the tool carrier arm to the outside plane of the tyre.

Take the mobile control unit to work position C.

- B. Rotate the wheel and at the same time move the hook tool forward inserting it between rim and bead until it is anchored to the bead (See Fig.7.6).
- C. Move the rim 4-5 cm from the tool taking care that it does not unhook from the bead.
- D. Move the hook tool towards the outside until the red reference dot is by the outside edge of the rim.

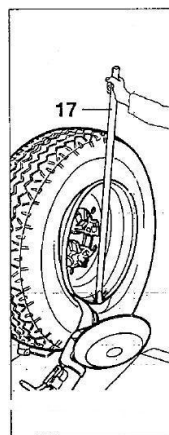

Fig.7.6

Take the mobile control unit to work position B.

- E. Insert lever LA (17, Fig.7.6) between rim and bead at the right of the tool.
- F. Press down on the lever and lower the wheel to bring the edge of the rim about 5 mm from the hooked tool.
- G. Turn the wheel anticlockwise pressing down on lever LA until the bead is completely off.

H. Move the tool carrier arm to its non-working position and then move it to the inside plane of the wheel.

Take the mobile control unit to work position D.

- I. Turn the hook tool 180° and insert it between rim and bead (see Fig.7.7). Move it until the bead is by the edge of the rim (best to do this with the wheel turning).
- J. Move the rim about 4-5 cm from the tool making sure the hook does not detach from the rim.

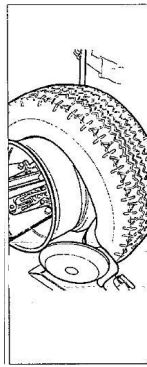

Fig.7.7

Take the mobile control unit to work position B.

- K. Move the hook tool so that its red reference dot is about 3 cm inside the rim.
- L. Insert lever LA (17, Fig.7.6), between rim and bead at the right of the tool.
- M. Press down on the lever and tower the wheel to bring the edge of the rim about 5 mm from the hooked tool.
- N. Turn the wheel anticlockwise pressing down on lever LA until the tyre comes completely off the rim.



DANGER!

When the beads come off the rim, the tyre will fail.

Check to make sure there are no by-standers in the work area.

7.2.3. Mounting

Tubeless tyres can be mounted using either the bead breaker disk or the hook tool. If the tyre is not problematic, use the bead loosener disk. If the tyre is very rigid, the-hook tool must be used.

7.2.3.1. Tyre mounting with the disk

Follow these steps:

- 1) If the rim has been removed from the spindle, put it back on the spindle as described in the section on "CLAMPING THE WHEEL".

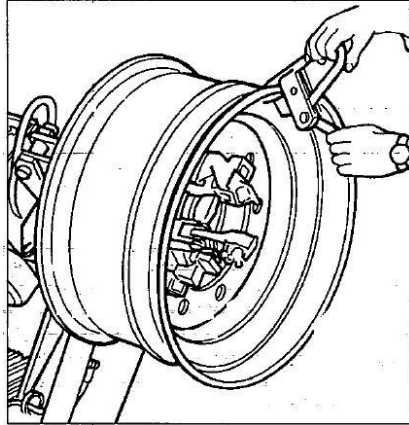

Fig.7.8

- 2) Lubricate both beads and the rim with tyre manufacturer recommended lubricant.
- 3) Attach the PC clip to the outside edge of the rim at the highest (See Fig. 7.8)

Take the mobile control unit to work position B.

- 4) Put the tyre on the platform and lower the spindle (make sure the clip is at the high point).
- 5) Lift the rim with the tyre hook to it and turn it anticlockwise about 15-20 cm. The tyre will be positioned tilted across the rim.

Take the mobile control unit to work position C.

- 6) Position the bead loosener disk against the second bead of the tyre and turn the spindle until the clip is at the low point (at 6 o'clock).
- 7) Move the disk away from the wheel.
- 8) Remove the clip and replace it at 6 o'clock outside the second bead (See Fig.7.9).

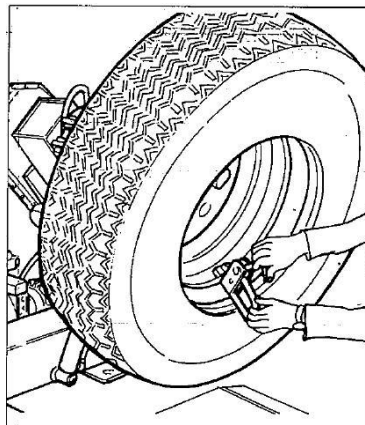

Fig.7.9

- 9) Turn the spindle clockwise **90°** to bring the clip to **9 o'clock**.
- 10) Move the disk forward until it is about 1-2 cm inside the edge of the rim. Begin to turn the spindle clockwise checking to make sure that, with a **90°** turn, the second bead begins to slip into the centre well.

11)When the bead is fully mounted, move the tool away from the wheel, tip it to its non-working position and remove the clip.

12)Lower the spindle until the wheel rests on the platform.

Take the mobile control unit to work position B.

13)Close the arms of the spindle completely. Support the wheel to prevent it falling off.



DANGER!

This operation can be extremely dangerous. Do it manually only if you are certain you can keep the wheel balanced.

-----For large and heavy tyres an adequate lifting device must be used.

14)Move the spindle as to set the wheel free.

15)Remove the wheel:

NB: If the tyre permits it, the operation described above can be speeded up by mounting both beads at the same time:

Follow-the steps described under points 1,2,3,4 described above but instead of attaching the clip to just the first bead (refer to point 4) clip it to both.

- Lift the rim with the tyre hooked to it and turn it anticlockwise 15-20 cm (clip at 10 o'clock).

- Follow the steps described in points 10,11,12,13,14,15 above.

7.2.3.2. Mounting with the hooked tool

- 1) Follow the steps described in points 1,2,3,4,5 for mounting with the disk.
- 2) Move the tool carrier arm to its non-working position. Move it to the inside plane of the tyre and rehook it at this position.
- 3) Check to make sure the hook tool is positioned on the wheel side. If not turn it 180°.

Take the mobile control unit to work position D.

- 4) Move the tool forward until the red reference dot is lined up with the outside edge of the rim and about 5 mm from it (See Fig.7.10).

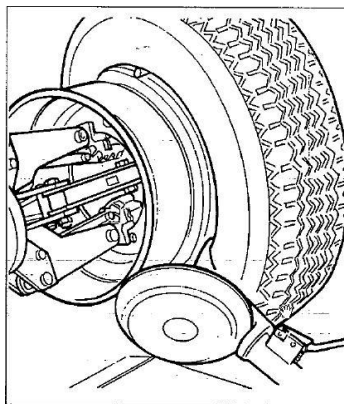

Fig.7.10

Take the mobile control unit to work position C.

- 5) Move to the outside of the wheel and check the exact position of the tool visually and adjust it as needed.

Then turn the spindle clockwise until the clip is at the bottom.(6 o'clock).

The first bead will be on the rim.

Take the mobile control unit to work position D.

- 6) Remove the clip.
- 7) Remove the tool from the tyre.
Move the tool-carrier arm to its non-working position.
- 8) Move it to the outside plate of the tyre and rehook it in this position.
- 9) Turn the tool 180°.
- 10) Attach the clip at the bottom (6 o'clock) outside the second bead (See Fig.7.9).

Take the mobile control unit to work position C.

- 11) Turn the spindle **clockwise** to about 90° (clip at 9 o'clock).
- 12) Bring the tool forward until the red reference dot is lined up with the outside edge of the rim and about 5 mm from it.
Begin to turn the spindle **clockwise** and check if, after about 90° of rotation the second bead Has started to slip into the centre well. Continue turning until the clip is at the bottom (6 o'clock). The second bead will now be mounted on the rim.
- 13) Follow the steps described in points 11,12,13,14,15 for mounting with the disk since this will ensure that the wheel is removed correctly from the machine.

7.3. Tubed wheels

7.3.1. BEAD BREAKING

WARNING: Unscrew the bush which fixes the valve when deflating the tyre so that the valve, coming in the inside of the rim, is not an obstacle during bead breaking.

Follow all the steps described previously for bead breaking tubeless tyres.

With tubed tyre, however, stop tool movement as soon as the bead has loosened to avoid damaging the tube inflation valve.

7.3.2. DEMOUNTING

- 1) Tip the tool carrier arm (14, Fig.6.3) to its non-working position. Move it to the outside plane of the wheel and rehook it in this position.
- 2) Rotate the wheel and at the same time move, the hook tool (18, Fig.6.3) forward inserting it between rim and bead until it is anchored to the tool.
- 3) Move the rim 4-5 cm from the tool taking care that it does not unhook from the bead.
- 4) Move the hook tool towards the outside until the red reference dot is by the outside edge of the rim.
- 5) Insert level LA (see Fig.7.11) between rim and bead at the right of the tool.

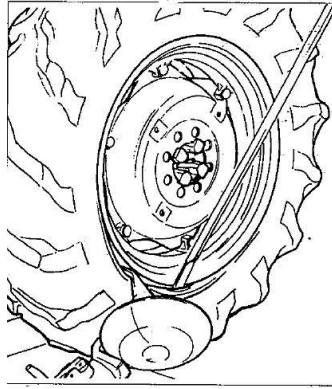

Fig.7.11

- 6) Press down on the lever and tower the wheel to bring the edge of the rim about 5 mm from the hooked tool.
- 7) Turn the wheel anticlockwise pressing down on lever LA until the bead is completely off.
- 8) Move the tool carrier arm to its non-working position. Lower the spindle until the tyre is pressed down against the platform. Move the spindle leftwards to provide sufficient space to remove the inner tube.
- 9) Remove the inner tube and lift the wheel back up.

Take the mobile control unit to work position D.

- 10) Move the tool carrier arm to the inside plane of the tyre, turn the hook tool 180° and tower the arm to its work position. Insert it between rim and bead and move it until the bead is by the from edge of the rim (best to do this with the wheel turning).
- 11) Move the rim about 4-5 cm from the tool making sure the hook does not detach from the rim.

Take the mobile control unit to work position B.

- 12) Move the hook tool so that its red reference dot is about 3 cm inside the rim. 1
- 13) Insert lever LA between rim and bead, at the right of the tool (See Fig. 7.12).

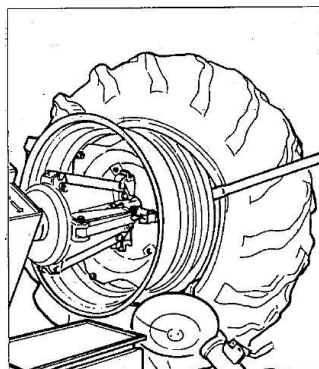

Fig.7.12

- 14) Press down on the lever and lower the wheel to bring the edge of the rim about 5 mm from the hooked tool. Turn the wheel anticlockwise pressing down on lever LA until the tyre comes completely off the rim.



DANGER!

When the beads come off the rim, the wheel will fall.
Check to make sure there are no by-standers-in the work area.

7.3.3. MOUNTING

- 1) If the rim has been removed from the spindle, put it back on the spindle as described in the section on "CLAMPING THE WHEEL".
- 2) Lubricate both beads and the rim with tyre manufacturer recommended lubricant.
- 3) Attach the PC clip to the outside edge of the rim at the highest point (See Fig.7.8).



CAUTION!

Make sure the clip is firmly attached to the rim.

Take the mobile control unit to work position B.

- 4) Put the tyre on the platform and tower the spindle (make sure the clip is at the high point) to hook the first bead on the clip.
- 5) Lift the rim with the tyre hook to it and turn it anticlockwise about 15-20 cm. The tyre will be positioned tilted across the rim.
- 6) Move the tool carrier arm to its non-working position. Move it to the inside plane of the tyre and rehook it in this position.
- 7) Check to make sure the hook tool is positioned on the wheel side. If not, turn it 180°.

Take the mobile control unit to work position D.

- 8) Move the tool forward until the red reference dot is lined up with the outside edge of the rim and about 5 mm from it.

Take the mobile control unit to work position C.

- 9) Move to the outside of the wheel and check the exact position of the hook visually and adjust it as needed. Then turn the spindle **clockwise** until the clip is at the bottom (6 o'clock).

The first bead will be on the rim. Remove the clip.

Take the mobile control unit to work position D.

- 10) Remote the tool from the tyre
- 11) Move the tool carrier arm to its non-working position. Move it to the outside plane of the tyre.
- 12) Turn the tool 180°

Take the mobile control unit to work position B.

- 13) Turn the spindle until the valve hole is at the bottom (6 o'clock).

- 14) Lower the spindle until the tyre is pressed down against the platform. Move the spindle leftwards to provide sufficient space to insert the inner tube.

NB: The valve hole may be asymmetrical to the centre of the rim. In this case position and insert the inner tube as shown in Fig.7.13.

Insert the valve through the hole and fix it with its locking ring.

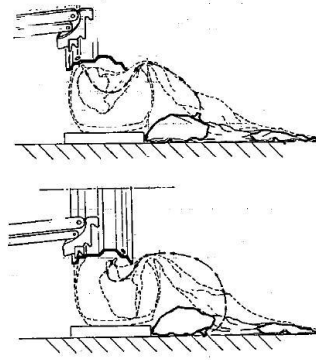

Fig.7.13

- 15) Place the inner tube in the centre welt of the rim (NB: to facilitate this, turn the spindle clockwise).

- 16) Turn the spindle until the valve is at the bottom (6 o'clock).

- 17) Inflate the inner tube a little (until it has no folds) so as not to pinch it while mounting the second bead.

- 18) Attach an extension to the valve and then remove the locking ring.

NB: The purpose of this operation is to allow the valve to be loose so that it is not ripped out during second bead mounting.

Take the mobile control unit to work position C.

- 19) Lift the wheel again and attach the PC clip outside the second bead about 20 cm to the right of the valve. (See Fig.7.14)

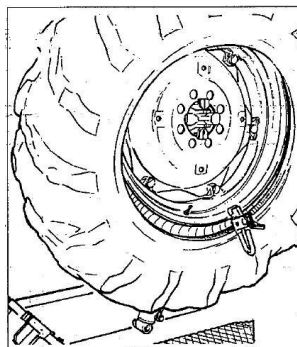

Fig.7.14

- 20) Turn the spindle clockwise until the clip is at 9 o'clock.
- 21) Move the tool carrier arm (14, Fig.7.15) to its working position.

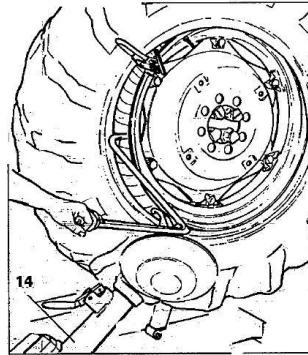

Fig.7.15

- 22) Bring the tool forward until the red reference dot is lined up with the outside edge of the rim and about 5 mm from it.
- 23) Turn the spindle a little clockwise until you can insert the bead guide lever into its seating on the hook tool (See Fig.7.15). This lever is furnished as an optional.
- 24) Pull back on this lever which will guide the bead into centre well. Continue to turn the spindle until the tyre is completely mounted on the rim.
- 25) Remove the PC clip. Remove the hook tool by turning the spindle anticlockwise and moving it towards the outside.
- 26) Tip the tool carrier arm to its non-working position.
- 27) Lower the spindle until the wheel rests on the platform.

Take the mobile control unit to work position B.

- 28) When the wheel is resting on the platform, check to make sure the valve is perfectly centered with its hole. If it is not, turn the spindle slightly to adjust the position. Fix the valve with its locking ring and remove the extension.
- 29) Close the arms of the spindle completely. Support the wheel to prevent it falling off.



DANGER!

This operation can be extremely dangerous, Do it manually only if you can keep the wheel balanced.

For large and heavy tyres an adequate lifting device must be used.

- 30) Move the spindle leftwards as to set the wheel free.
- 31) Remove the wheel.

7.4. Wheels with split ring

7.4.1. Bead breaking and demounting

7.4.1.1. Wheel with 3-piece rings

- 1) Clamp the wheel on the spindle as described previously and check to make sure it has been deflated.

Take the mobile control unit to work position B.

- 2) Lower the tool carrier arm (14, Fig.7.16) to its work position until it is locked in position by its hook.

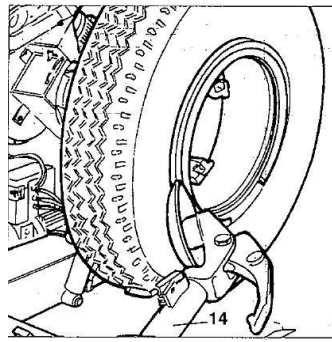

Fig.7.16

- 3) Position the bead loosener disk level with the rim (See Fig.7.16).
- 4) Turn the spindle and at the same time move the disk forward a bit at a time following the contour of the rim until the first bead is completely free (NB: lubricate while doing this).
CAUTION! If the tyre has an inner tube, work very carefully and be prepared to stop the disk immediately once the bead has been broken so as not to damage the valve and the inner tube.
- 5) Repeat this procedure but this time bring the disk against the split-ring (See Fig.7.17) until the lock ring is freed. Remove this with the special lever LC (23, Fig.7.17) or with the help of the disk.

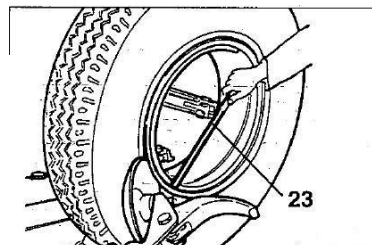

Fig.7.17

- 6) Remove the split-ring.
- 7) Move the tool carrier arm (14, Fig.7.16) back from the edge of the rim. Release the hook and tip the arm to its non-working position.

Move the tool carrier arm to the inside plane of the wheel.

- 8) Turn the tool head 180°
Lower the arm to its working position.
- 9) Turn the spindle and at the same time bring the bead loosener disk up against the tyre following the contour of the split-ring until the second bead has been broken (MB: Lubricate during this process). Continue to move the disk forward until about half the tyre has demounted from the rim (See Fig.7.18).

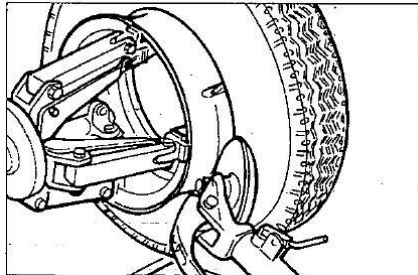

Fig.7.18

- 10) Move the tool carrier arm to its non-working position.
- 11) Lower the spindle until the wheel is resting on the platform.

Take the mobile control unit to work position B.

- 12) Move the spindle leftwards the outside until the tyre is completely off the rim. Watch out for the valve.

7.4.1.2. Wheel with 5-segment split rings

- 1) Clamp the wheel on the spindle as described previously and make sure it is deflated.

Take the mobile control unit to work position B.

- 2) Lower the tool carrier arm (14, Fig.7.10) to its work position until its hook has clicked into position on the bar.
- 3) Use the joystick to position the wheel so that the bead breaker disk touches up against outside edge of the centre well rim.
- 4) Turn the spindle and at the same time move the bead breaker disk forward until the split-ring is detached. Watch out for the O-ring.
- 5) Repeat this operation but this time move the disk against the split-ring (See Fig.7.17) until the locking ring is released, this ring can be removed with the special LC lever (23, Fig.7.17) or with the help of the bead disk.
- 6) Remove the O-ring.
- 7) Move the tool carrier arm (14, Fig.6.3) back from the edge of the rim.
Tip the arm to the non-work position. Move the tool carrier arm to the inside plane of the wheel.
- 8) Turn the tool head 180°.
Lower the arm to its working position

Take the mobile control unit to work position D.

- 9) Turn the spindle and at the same time bring the bead loosener disk up-against the tyre

between the rim and bead. Move the disk into the tyre only when the bead has started to detach from the rim and move the bead to the outside edge of the rim.

(NB: Lubricate during this process).

10) Tip the tool carrier arm to its non-work position.

Take the mobile control unit to work position B.

11) Lower the spindle until the wheel is fastening on the platform.

12) Move the spindle leftwards until the tyre together with the split ring comes completely off the rim.

13) Remove the rim from the spindle.

14) Position the tyre on the platform with the splint ring turned towards the spindle.

15) Clamp the split ring on the spindle as explained in the section of CLAMPING THE WHEEL.

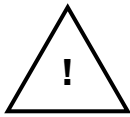

DANGER!

The tyre is not attached to the split ring.

Any strain on it during positioning or clamping operations could cause it to detach and fall.

Take the mobile control unit to work position D.

16) Move the tool carrier arm back to its work position.

17) Position the spindle so that the bead breaker disk is lined up with the bead.

18) Turn the spindle and move the disk forward until the tyre comes completely off the split ring.

NB: This double bead breaking procedure can be eliminated by using the **PAIR OF MV CLAMPS** (optional) that fix the split-ring to the rim so that they are broken out at the same time. The MV clamps come complete with operating instructions.



DANGER!

When the beads come off the rim, the wheel will fall.

Check to make sure there are no by-standers in the work area.

7.4.2. MOUNTING

7.4.2.1. Wheels with 3-piece split-rings

1) Move the tool carrier arm to its non-working position. If the rim has been removed from the spindle, put it back on the spindle as described in the section on "CLAMPING THE WHEEL".

If the tyre is tubed, position the rim with the valve slot at bottom (6 o'clock).

2) Lubricate both beads and the rim with tyre manufacturer recommended lubricant.

Take the mobile control unit to work position B.

3) Move the tyre on the platform.

NB: If the tyre is tubed, position the rim with the valve slot at the bottom (6 o'clock).

- 4) Lower or raise the spindle to centre the rim and the tyre.
- 5) Move the spindle rightwards until the rim is inserted into the tyre.

CAUTION! If the tyre is tubed push the valve inside so as not to damage it.

Move forward with the platform until rim is completely in the tyre.

- 6) Bring the tool carrier arm to the outside plane and lower it to its work position with the disk towards the wheel.

NB: If the tyre is not inserted sufficiently on the rim, move the spindle until the tyre bead is by the disk. Bring the disk forward (with the spindle turning) until it is completely inserted.

- 7) Put the split-ring on the rim and then install the locking ring with the help of the disk as shown in Fig.7.19.

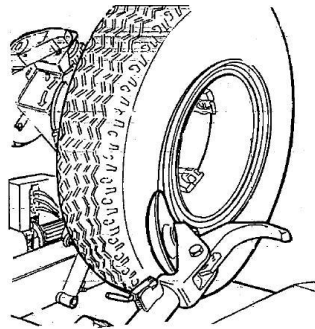

Fig.7.19

- 8) Move the tool carrier arm to its non-working position and, at the same time, close the spindle arms. Support the wheel so that it does not fall off.



DANGER!

This operation can be extremely dangerous, Do it manually only if you can keep the wheel balanced.

For large and heavy tyres an adequate lifting device must be used.

- 9) Move the spindle to free the wheel.
- 10) Remove the wheel.

7.4.2.2. Wheels with 5-segment split-rings

- 1) Move the tool carrier arm to its non-working position. If the rim has been removed from the spindle, put it back on the spindle as described in the section on "CLAMPING THE WHEEL".
- 2) Lubricate both beads and the rim with tyre manufacturer recommended lubricant.

Take the mobile control unit to work position B.

- 3) Move the tyre on the platform.
- 4) Lower or raise the spindle to centre the rim and the tyre.
- 5) Move the spindle rightwards until the rim is inserted into the tyre. Move forward with the platform until rim is completely in the tyre.
- 6) Put the split-ring on the rim and (with the lock ring already mounted) ,

NB: If the rim and the split-ring have slits for fixing devices, make sure they are lined up with each other.

Take the mobile control unit to work position C.

- 7) Move the tool carrier arm to the outside in its work position with the bead breaker disk turned towards the wheel.

NB: If the splitting is not inserted sufficiently on the rim, move the spindle until the split ring is by the disk. Bring the disk forward (with the spindle turning) until you “discover” the O-ring seating.

- 8) Lubricate the O-ring and its seating.
- 9) Position the locking ring on the rim with the help of the disk as shown in Fig.7.19.
Move the tool carrier arm to its non-working position and close the spindle arms completely. Support the wheel so that it does not fall off the spindle.



DANGER!

This operation can be extremely dangerous, Do it manually only if you can keep the wheel balanced.

For large and heavy tyres an adequate lifting device must be used.

Move the spindle to free the wheel.

Remove the wheel.



DANGER!

Do not inflate the tyre with the wheel mounted on the spindle.

Tyre inflation is dangerous and should only be done by removing the wheel from the spindle and placing it inside a safety cage.

8. Ordinary maintenance



WARNING!

Each maintenance operation must be effected only after the disconnection of the plug from electric network.

To ensure that this Worker TY008 tyre changer works perfectly over the years, carry out the routine-maintenance schedule described.

- 1) Lubricate the following parts from time to time, after a thorough cleaning with naphtha:
 - The various swivels on the spindle
 - The tool bracket slide runner
 - The carriage guide plate
- 2) Grease the spindle bracket lift cylinder from time to time and also its swivel. Add the grease through the grease nipples (See Fig.8.1) using ordinary lubricating grease.
In the same way, grease the tool holder arm cylinder (See Fig.8.2).
- 3) From time to time, with the help of maximum and minimum warning lights on the tank of the hydraulic power pack, check the oil level in the pack.

If necessary top up with Esso Nuto H46 or similar hydraulic oil (eg. Agip Oso46, Shell Tellus Oil 46, Mobil DTE25, Castrol Hyspin AWS 46, Chevron RPM EP Hydraulic Oil 46, BP Energol HLP).

Unscrew the cap (30, Fig.8.3) put oil in, screw the cap and lock it again.

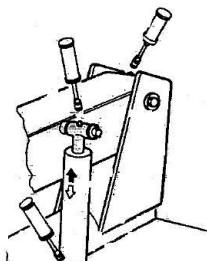

Fig.8.1

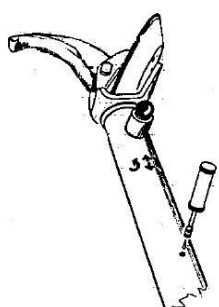

Fig.8.2

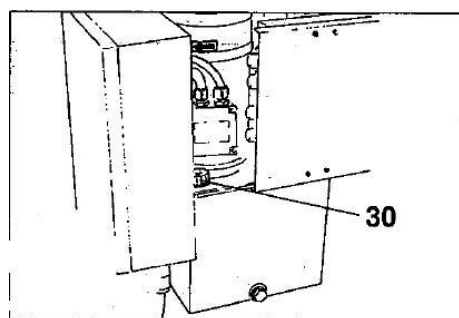

Fig.8.3

WARNING!



The Oil tank cap should not be opened by un-trained person.
The operator must lock the cap, after the screw the cap.

- 4) From time to time check the oil level in the gear unit which, when the tool carrier bracket is completely lowered at end travel, should not show the sight glass on the gear casing as completely empty. If necessary top up with Esso Spartan EP 320 or similar oil (eg, Agip F1 REP 237, BP GRX P 320, Chevron Gear Compound 320, Mobil Gear 632, Shell Omaia Oil 320, Castrot Alpha SP 320). Remove the cap (31, Fig.8.4), put in oil and lock the cap again.

NB: If the oil in the gear unit or the hydraulic power pack has to be changed, note that the gear unit casing and the power pack reservoir have specific drain plugs.

- 5) Check the horizontal arm periodically.

N.B.: There may be some mechanical play at the tool-holder arm, or while moving it, during the assembly and disassembly operations. For longer component working life, it is advisable to adjust the slide shoes as described below.

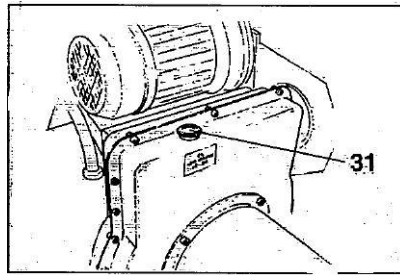

Fig.8.4

Material Safety Data Sheet

Hydraulic Oil 46:

Physical State	Liquid.	Color	Light amber to amber	Odor	Mild petroleum odor
Specific Gravity	0.87 (Water = 1)	pH	Not Applicable.	Vapor Density	>1 (Air = 1)
Boiling Range	Not available.			Melting/Freezing Point	Not available.
Vapor Pressure	<0.001 kPa (<0.01 mm Hg) (at 20°C)			Volatility	Negligible volatility.
Solubility in Water	Negligible solubility in cold water.			Viscosity (cSt @ 40°C)	33
Flash Point	Open cup: 212°C (414°F) (Cleveland.).				
Additional Properties	Gravity, °API (ASTM D287) = 31.3 @ 60° F Density = 7.42 Lbs/gal. Viscosity (ASTM D2161) = 170 SUS @ 100° F				

Hydraulic Oil 32:

Physical State	Liquid.	Color	Light amber to amber	Odor	Mild petroleum odor
Specific Gravity	0.87 (Water = 1)	pH	Not Applicable.	Vapor Density	>1 (Air = 1)
Boiling Range	Not available.			Melting/Freezing Point	Not available.
Vapor Pressure	<0.001 kPa (<0.01 mm Hg) (at 20°C)			Volatility	Negligible volatility.
Solubility in Water	Negligible solubility in cold water.			Viscosity (cSt @ 40°C)	33
Flash Point	Open cup: 212°C (414°F) (Cleveland.).				
Additional Properties	Gravity, °API (ASTM D287) = 31.3 @ 60° F Density = 7.42 Lbs/gal. Viscosity (ASTM D2161) = 170 SUS @ 100° F				

Tool-holder carriage slide shoe adjustment

- a) Disconnect the machine from the mains.
 - b) Lift the tool-holder arm to the outside working position
 - c) Loosen the guard fixing screws (1 Fig.8.5), remove the chain guard (2 Fig.8.5).
 - d) Loosen the nuts (3 Fig.8.5)for each upper slide shoe of the carriage (4 Fig.8.5).
 - e) Loosen the four register locking nuts (1 Fig.8.6).
 - f) Screw each of the six slide shoe register screws (2 Fig.8.6) a quarter turn.
 - g) Tighten the four locking nuts of the upper slide shoes (3 Fig.8.5)
 - h) Tighten the four register locking nuts (1 Fig.8.6)
 - i) Refit the guard on the chain V2 Fig.8.5).
- H. B.: If the adjustment is insufficient, and there is still play, adjust the screws further, repeating the procedure described above until all mechanical play has been eliminated.

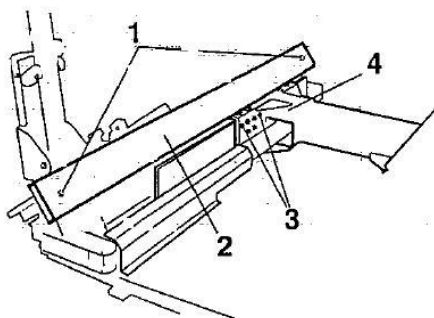

Fig.8.5

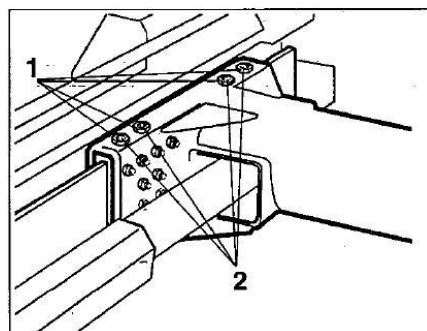

Fig.8.6



WARNING!
Dispose of the used oil following the present legislation on the matter.



WARNING!
If this machine catches fire, use dust or CO² extinguisher only.

9. Trouble shot

PROBLEM

After having switched the general button on the electric pack, the general warning light does not light on and no control can function.

CAUSES

- 1) The power supply cable loses and disconnects the electric supply.
- 2) No power from the mains electric supply.

REMEDIES

- 1) Reconnect the power supply cable to the electric supply.
- 2) Reset the mains electric supply.

PROBLEM

After having switched the general button on the general warning light also switches on but the motor on the hydraulic power pack does not function.

CAUSES

The magneto-thermic switch for motor protection is working.

REMEDIES

Call for technical aid to see what the problem is and restore the machine.

PROBLEM

The manometer (21, Fig.3.2) reads a pressure value below 130 bar \pm 5%

CAUSES

The handle (20, Fig.3.2) is not properly adjusted.

The oil in the power pack is below minimum level.

REMEDIES

Turn the handle (20, Fig.3.2) clockwise until you get the pressure value required.

Read the paragraph "MAINTENANCE" to add oil.

10. Accessories and tools

Bead locking clip:



Fig.10.1

Bead lifting lever:



Fig.10.2

11. Electric drawing

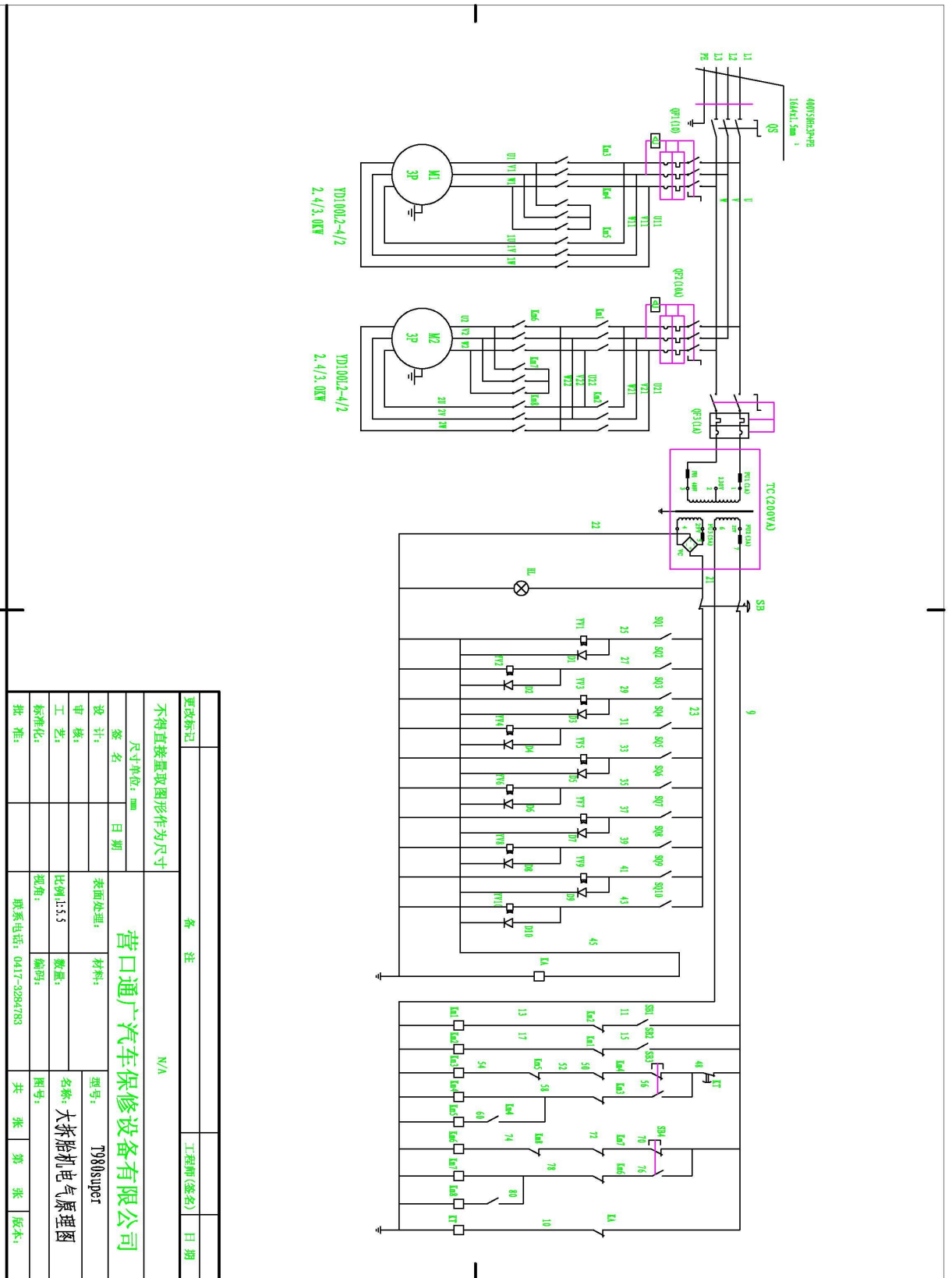

更改标记	备注	工程师(签名)	日期
不得直接量取图形作为尺寸			
尺寸单位: mm		N/A	
签名	日期	表面处理:	型号: T980super
设计:		材料:	名称: 大拆胎机电原理图
审核:		数量:	
工艺:		比例: 1:3.5	
标准化:		视角:	
批准:		编码:	
	联系电话: 0417-3284788	图号:	
		共 张	第 张
		版本:	

12. Hydraulic drawing

